

MUNICIPAL

SEWER  
&

WATER™

FOR SANITARY, STORM AND WATER SYSTEM MAINTENANCE PROFESSIONALS

September 2016

[www.mswwmag.com](http://www.mswwmag.com)

2016-2017  
**BUYER'S  
GUIDE**

**PAGE 60**

BETTER MOUSETRAPS: CLEAN SEWERS  
WITH LESS WATER

**PAGE 34**

# BETTER THAN THEY FOUND IT

Pennsylvania utility emphasizes longevity  
and takes a proactive approach  
to system setup and maintenance

**PAGE 26**



Jeremy Trout  
Public Works Director  
Windsor Township, Pennsylvania

# An instant, wireless View into any sewer.



Sewer assessment—it's essential to prioritizing CCTV and maintenance work, planning cleaning and rehab, and achieving compliance. Controlled wirelessly with a touchscreen tablet, the patented new **Quickview airHD** camera lets you look inside any sewer with:

**No cables at all!**

**Touchscreen control**

**Detailed HD video**

**In-manhole centering**

**Motorized tilt**

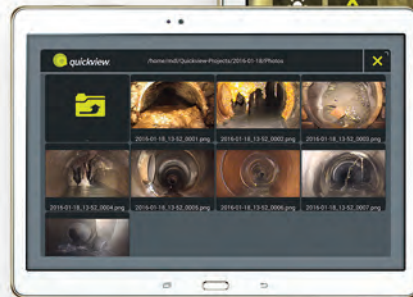
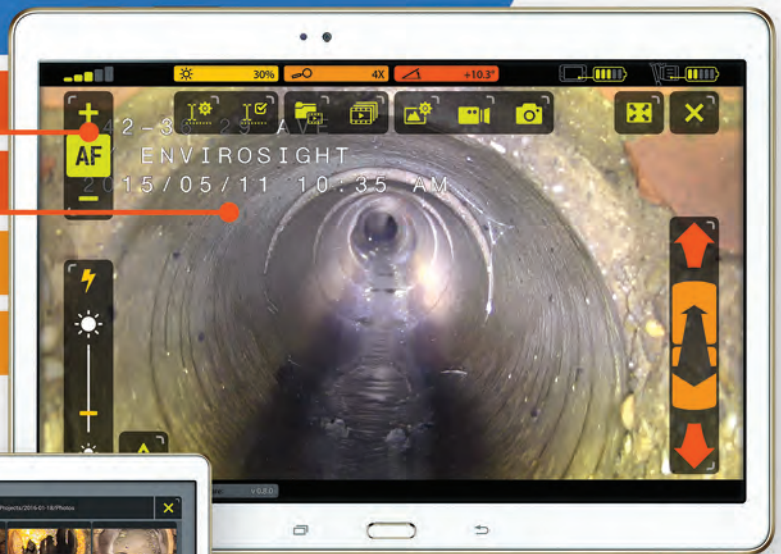

Full wireless control, viewing, recording, annotation, playback and sharing capabilities.



[envirosight.com/airhd](http://envirosight.com/airhd) • (973) 252-6700

Phased Assessment Strategy for Sewers (PASS) starts with zoom assessment. This FREE white paper explains why: [envirosight.com/pass](http://envirosight.com/pass)



get a **demo**

Full range of underground infrastructure inspection equipment, service and rentals.

©2016 EnviroSight. All rights reserved. Quickview and EnviroSight names/logos are trademarks of EnviroSight. Patents 6,538,732 and 7,009,698; others pending. Specifications subject to change without notice.



# PERFECT STORM. SIMPLE SOLUTION.

**VACTOR**  
Subsidiary of Federal Signal Corporation

## COUNT ON US AS YOUR SOLUTION.

Featuring the 2100 Plus Combination Sewer Cleaner line, the Vactor Factor is the only way to describe the proven service our clients have come to expect from us. Experience the easy operation, exceptional efficiency and unmatched quality and support for yourself.

## SCHEDULE A DEMO TODAY!

Visit [Vactor.com](http://Vactor.com) or call 815.672.3171

**weftec 2016**  
Booth 4239

**VACTOR**  
Subsidiary of Federal Signal Corporation



# INSIDE:

ANNUAL BUYER'S GUIDE/  
STORMWATER MANAGEMENT  
AND I&I PREVENTION

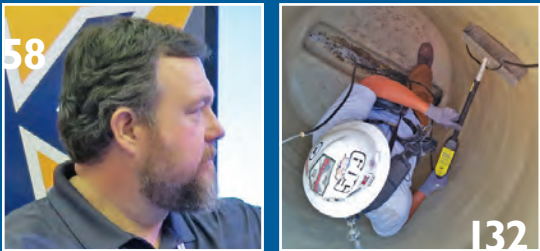

## ON THE COVER:

Public Works Director Jeremy Trout  
at the Panorama Hills Pump Station  
in Windsor Township, Pennsylvania.  
(Photography by James Robinson)



## COMING IN OCTOBER 2016

### Flow Control & Monitoring

- ◆ HUMAN SIDE: Develop a culture of collaboration
- ◆ TECH TALK: Innovative technologies for automated metering
- ◆ SEWER: Expanding Sudbury's rock tunnel system

## FEATURES

### 14 SEWER/WATER: A Community That Will Last

Pueblo of Acoma Utility Authority stretches limited resources to bridge historic past with a more modern future.

By Peter Kenter

### 26 SEWER: Better Than They Found It

Pennsylvania utility emphasizes longevity and takes a proactive approach to system setup and maintenance.

By Mary Shafer

### 40 SEWER/WATER: Fighting for Infrastructure Funding

Local leaders pull together to secure state funding for badly needed infrastructure upgrades in Tallulah, Louisiana.

By Ted J. Rulseh

## COLUMNS

### 8 FROM THE EDITOR: Sticking With the Story

A few pages in a magazine can't do justice to all the work you do, so we're going a few steps further.

By Luke Laggis

### 10 @mswmag.com

Visit daily for news, features and blogs. Get the most from *Municipal Sewer & Water* magazine.

### 22 HUMAN SIDE: The Facts About Feedback

Regularly asking for and receiving candid performance evaluations is a developmental tool every employee should master.

By Ken Wysocky

### 34 BETTER MOUSETRAPS: Running on Empty

Water-recycling vac trucks could eliminate the use of potable water for cleaning sewers.

By Ken Wysocky

### 48 NASSCO CORNER: Back to School

Education never ends for those pushing the trenchless industry forward.

By Ted DeBoda

### 50 WEFTEC PRODUCT PREVIEW

By Craig Mandli

### 58 WWETT SPOTLIGHT: Mapping Laterals in Real Time

RapidView IBAK North America's 3-D GeoSense program maps while you inspect.

By Luke LeNoble

### 60 2016-2017 Annual Buyer's Guide

### 126 PRODUCT FOCUS: Stormwater Management and I&I Prevention

By Craig Mandli

### 132 CASE STUDIES: Stormwater Management and I&I Prevention

By Craig Mandli

### 136 PRODUCT NEWS

Product Spotlight: Compact Ventis Pro5 simplifies gas detection and response.

By Luke LeNoble

### 142 INDUSTRY NEWS

### 150 WORTH NOTING

SEPTEMBER 2016

MUNICIPAL  
**SEWER  
&  
WATER**





**PERMA-LINER  
INDUSTRIES, LLC.**

Two solutions for

# MAIN LINE REHABILITATION



## SECTIONAL POINT REPAIR

- REHABILITATING SECTIONS OF THE MAIN SEWER LINE.
- COMPLETE START-UP SYSTEMS FOR LESS THAN \$15,000. INCLUDES ON-SITE TRAINING, KITS AND ALL EQUIPMENT.



## PERMA-MAIN™

- REHABILITATING THE MAIN SEWER LINE WITH CONTINUOUS MANHOLE TO MANHOLE LINING.
- PATENT PENDING.



**LIVE DEMONSTRATIONS:** WISCONSIN 9/12 & 9/13

COME SEE US AT  
**WEO FAIR**  
MILWAUKEE



Turn-Key Trailers &  
Turn-Key Box Trucks



Zero Down, No Payments  
for 90-Days













[perma-liner.com](http://perma-liner.com)





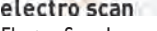



To learn more call  
**1-866-336-2568**



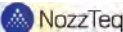







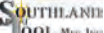



# ADVERTISER INDEX

COMPANY	PAGE
3T Equipment Company Inc.....	115
ADS LLC .....	29
Advanced Aquatic Products International, Inc. ....	107
Advanced Infrastructure Technologies .....	8
Agru America, Inc. ....	55
 American Highway Products, Ltd. ....	97
American Pleasure Products, Inc. ....	111
American Shoring, Inc. ....	57
 AMT Pump Company .....	83
AP/M Permaform.....	67
Applied Felts, Inc. ....	9
 Aries Industries, Inc. ....	123
Arthur Products Co. ....	56
Best Management Products, Inc. ....	24
Blue-White Industries.....	17
 Cam Spray .....	38
 Chempace Corporation.....	46
 Cloverleaf Tool Co. ....	115
Cretex Specialty Products .....	24
 CUES .....	15
 Duke's Root Control, Inc. ....	13
Efficiency Production, Inc. ....	32
 Electro Scan Inc. ....	153
 Envirosight .....	2
 Enz USA, Inc. ....	77
Famhost.....	56
Ferguson Waterworks.....	49
FlowMark Vacuum Trucks.....	79
Formadrain, Inc. ....	135
 GapVax, Inc. ....	155
 HammerHead Trenchless Equipment.....	45
Helix Laboratories, Inc. ....	63

COMPANY	PAGE
 Hi-Vac Corporation .....	151
Hurco Technologies, Inc. ....	20
 InfoSense, Inc. ....	95
Infrastructure Repair Systems Inc. ....	46
Inliner Technologies.....	23
IPEX Inc. ....	125
JWC Environmental.....	32
KEG Technologies, Inc. ....	107
Komline-Sanderson.....	65
Krausz USA.....	81
LADTECH, Inc. ....	85
Lee Supply Company.....	12
LMK Technologies .....	143
Matchpoint Water Asset Management, Inc. ....	133
McGard LLC .....	87
Miller Pipeline.....	71
Mr. Manhole.....	55
 MyTana Mfg. Company, Inc. ....	12
NCFI Polyurethanes.....	129
 NozzTeq, Inc. ....	105
Parson Environmental Products, Inc. ....	109
 Perma-Liner Industries, LLC .....	5
Petersen Products Co. ....	113
Pipeline Renewal Technologies.....	37
<b>PIPELOGIX</b> PipeLogix, Inc. ....	117
PRIMEX.....	56
Proco Products, Inc. ....	103
ProComSol, Ltd.....	101
 Pronal-USA, Inc. ....	113
 R.S. Technical Services, Inc. ....	31
 RapidView IBAK North America .....	131
Red Valve Co. / Tidedex Technologies.....	19
Reed Manufacturing Co. ....	99
Reline America, Inc. ....	11
RELINER/Duran Inc. ....	38
Rental Tools Online.....	32
Root Rat.....	111
 RootX .....	39

COMPANY	PAGE
SAERTEX-multiCom.....	75
Sauereisen, Inc. ....	38
Sealing Systems, Inc. ....	101
Sewer Equipment.....	149
Simpson Strong-Tie Company, Inc. ....	7
 Southland Tool Mfg. Inc. ....	47
Spartan Tool .....	21
Specialty Maintenance Products, Inc. ....	89
Sto-Away Power Cranes, Inc. ....	109
 SubSurface Locators, Inc. ....	24
Sunbelt Rentals .....	139
 Super Products LLC .....	25
 T&T Tools, Inc. ....	103
The Strong Company, Inc. ....	43
Thompson Pipe Group.....	46
Total Piping Solutions, Inc. ....	93
 Trio Vision LLC dba Cobra Tech .....	27
Trumbull Industries, Inc. ....	12
 Ultra Shore .....	99
 USB - Sewer Equipment Corporation .....	69
 Vac-Con, Inc. ....	156
Vacall - Gradall Industries .....	33
 Vactor Manufacturing .....	3
Vaporoooter .....	137
Vaughan Company, Inc. ....	73
VEGA Americas, Inc. ....	141
Venco Venturo Industries LLC .....	105
Vivax-Metrotech Corp. ....	154
 WinCan, LLC.....	91
WWETT Show .....	59
Xceed Machine Works Inc. ....	20
CLASSIFIEDS .....	152
MARKETPLACE .....	144



FOR SANITARY, STORM AND WATER SYSTEM MAINTENANCE PROFESSIONALS

Published monthly by:



1720 Maple Lake Dam Rd., PO Box 220, Three Lakes WI 54562



www.mswmag.com

© Copyright 2016, COLE Publishing Inc. No part may be reproduced without permission of publisher.

In U.S. or Canada call toll free 800-257-7222 Elsewhere call 715-546-3346

Email: info@mswmag.com / Fax: 715-546-3786

Office hours Mon.-Fri., 7:30 a.m.-5 p.m. CST

**SUBSCRIPTIONS:** A one year (12 issue) subscription to *Municipal Sewer & Water*™ in the United States, Canada and Mexico is free to qualified subscribers. A qualified subscriber is any individual or company in the United States, Canada and Mexico that maintains, manages, designs or installs municipal or commercial sewer, water and storm infrastructures. To qualify, visit [www.mswmag.com](http://www.mswmag.com) or call 800-257-7222.

Non-qualified subscriptions are available at a cost of \$60 per year in the United States and Canada/Mexico. Subscriptions to all other foreign countries cost \$150 per year. To subscribe, visit [www.mswmag.com](http://www.mswmag.com) or send company name, mailing address, phone number and check or money order (U.S. funds payable to COLE Publishing Inc.) to the address above. MasterCard, VISA, American Express and Discover are also accepted. Include credit card information with your order.

Our subscriber list is occasionally made available to carefully selected companies whose products or services may be of interest to you. Your privacy is important to us. If you prefer not to be a part of these lists, please contact Nicole at [nicole.labeau@colepublishing.com](mailto:nicole.labeau@colepublishing.com).

**CLASSIFIED ADVERTISING:** Submit classified ads online at [www.mswmag.com/classifieds](http://www.mswmag.com/classifieds). Minimum rate of \$25 for 20 words; \$1 per each additional word. All classified advertising must be paid in advance. **DEADLINE:** Classified ads must be received by the first of the month for insertion in the next month's edition. **PHONE-IN ADS ARE NOT ACCEPTED.** Fax to 715-546-3786 only if charging to MasterCard, VISA, Discover or AmEx. Include all credit card information and your phone number (with area code). **Mail** with check payable to COLE Publishing Inc. to the address above. **CLASSIFIED ADVERTISING APPEARS NATIONWIDE AND ON THE INTERNET.** Not responsible for errors beyond first insertion.

**DISPLAY ADVERTISING:** Contact Jim Koshuta or Kayla Bisnette at 800-994-7990. Publisher reserves the right to reject advertising which in its opinion is misleading, unfair or incompatible with the character of the publication.



Jim Koshuta Kayla Bisnette

**EDITORIAL CORRESPONDENCE:** Send to Editor, *Municipal Sewer & Water*, PO. Box 220, Three Lakes, WI, 54562 or email [editor@mswmag.com](mailto:editor@mswmag.com).

**REPRINTS AND BACK ISSUES:** Visit [www.mswmag.com](http://www.mswmag.com) for options and pricing. To order back issues, call Nicole at 800-257-7222 (715-546-3346) or email [nicole.labeau@colepublishing.com](mailto:nicole.labeau@colepublishing.com). To order reprints, call Jeff Lane at 800-257-7222 (715-546-3346) or email [jeff.lane@colepublishing.com](mailto:jeff.lane@colepublishing.com).

**CIRCULATION:** 2015 average circulation was 37,623 copies per month (U.S. and international distribution).

 [www.facebook.com/MSWmag](http://www.facebook.com/MSWmag)  
 [www.twitter.com/MSWmagazine](http://www.twitter.com/MSWmagazine)  
 [www.plus.google.com](http://www.plus.google.com)  
 [www.youtube.com/MunicipalSewerWater](http://www.youtube.com/MunicipalSewerWater)  
 [www.linkedin.com/company/municipal-sewer-&-water-magazine](http://www.linkedin.com/company/municipal-sewer-&-water-magazine)



Water & Wastewater Equipment, Treatment & Transport Show  
**www.wwettshow.com**

Education Day: Wed., Feb. 22, 2017  
 Exhibits: Thurs.-Sat., Feb. 23 - 25, 2017  
 Indiana Convention Center, Indianapolis, Ind.



# Stop water dead in its tracks.



## Introducing RPSInject from Simpson Strong-Tie

Stop water leaks without costly excavations. RPSInject™ polyurethane injection resins give you a safe, versatile and easy-to-use solution for repairing cracks to prevent water infiltration. These non-toxic, non-flammable expanding resins are available in four formulations and adjustable cure times to help you solve your next concrete repair challenge.

With RPSInject resins, you can repair in place. Call us about your project at (800) 999-5099 or visit [strongtie.com/rpsinject](http://strongtie.com/rpsinject).

**SIMPSON**  
**Strong-Tie**



# STICKING WITH THE STORY

A few pages in a magazine can't do justice to all the work you do, so we're going a few steps further



## FROM THE EDITOR

Luke Laggis

I write this column every month. Sometimes it's easy and sometimes, like right now, trying to give voice to any useful sentiment is just a slow, painful process. And sometimes I'm convinced no one will ever read a word of it anyway, so it's always nice when someone comments on it.

I'm sure you feel the same in your jobs sometimes. Sometimes — probably far too often — you do great work and it seems like no one notices, while the smallest perceived mistake draws more needless attention than the Kardashians.

I've heard so many of you talk about how no one pays any attention to sewer and water systems until there's a problem. I've heard the phrase "out of sight, out of mind" used in reference to underground infrastructure

countless times. It's a battle you face daily. You're the unsung heroes of modern sanitation, but sometimes a little positive feedback, or just some basic recognition, goes a long way.

Our coverage of the Downtown Streetscape Project in my hometown of Rhinelander, Wisconsin, is aimed at doing just that. We featured the project in last month's issue of *MSW*, but we're not just sharing this story and forgetting about it as we move on to the next. You need to see your projects through to completion, and we're seeing this one through, too.

We gave you a good overview of the \$10 million project in August, but like every story, every project, there's much more to it. The general public may only understand the immediate and direct impact on their day-to-day lives — typically the traffic disruption — but we know there's more and we want to share it with you.

Good projects deserve recognition, and I think there's something you can gain from getting a good look at every facet of a project like this. It covers water and wastewater. It requires a high level of engineering, and flexibility to adjust to the unexpected. Its smooth execution requires clear and constant communication with affected property owners and the community at large. The town also has a colorful, industrial history, and there's a definite downtown revitalization angle here, with significant socioeconomic impact.

We try to give you a well-rounded picture in our profiles, so this time we're sticking with the story. There's already an update to last month's profile on the Rhinelander project at [mswmag.com/Rhinelander](http://mswmag.com/Rhinelander). There's also a photo gallery we're continually updating, and some of those other pieces I mentioned above. We'll be posting new content regularly, and telling the stories within the story so you can get a complete picture.

This is an opportunity to dig deeper, follow the project through to completion, and ideally to learn more from those challenges and successes. I hope you're able to do just that.

Enjoy this month's issue. ♦

Comments on this column or about any article in this publication may be directed to editor Luke Laggis, 800/257-7222; [editor@mswmag.com](mailto:editor@mswmag.com).

**Advanced**  
Work Horse Nozzles

Is Actively Seeking Dealers In Prime Geographies

Contact us

Featuring the industry leading Near Diamond Hard (NDH™) Conical Ceramic Jets

Advanced Infrastructure Technologies, LLC  
Toll Free: 1-844-NOZZLES (1-844-669-9537)  
[www.advancedworld.com](http://www.advancedworld.com)  
Interested Dealers please contact [JP@AdvancedWorld.com](mailto:JP@AdvancedWorld.com)

Advanced Workhorse Nozzles are manufactured in Germany and the USA

Protected Geography Policy · Aggressive Demo Promotions · Personalized Catalogs

**Got News?**

Newsworthy items may include business expansion, honors and awards, new contract announcements, employee promotions, executive hires and new services.

Send your info to: [editor@mswmag.com](mailto:editor@mswmag.com)



# LEADING THE WORLD OF CIPP IS IN OUR FIBER.



ISO 9001:2008  
FM 56735  
FM 588513

Everything we do at Applied Felts — from maintaining full control of our raw materials to helping ensure every felt liner we make is successfully installed — makes us the global leader in supplying the world's finest CIPP liners. It's who we are because Applied Felts was there from the beginning, helping take the first innovative steps to invent the CIPP process over 40 years ago. Now we are taking the next big leap by introducing our latest innovation, AquaCure PS®. This breakthrough liner provides the most innovative CIPP custom solutions for your pressure pipe applications. Our exclusive technology fully integrates and blends state-of-the-art strength with millions of feet of proven results to provide the highest quality liners for pressure sewer and non-potable water applications. AquaCure PS is just one more reason customers from Singapore to San Francisco depend on us year after year. They know what we're made of.



appliedfelts.com  
US: 276.656.1904  
UK: 44.1924.200535

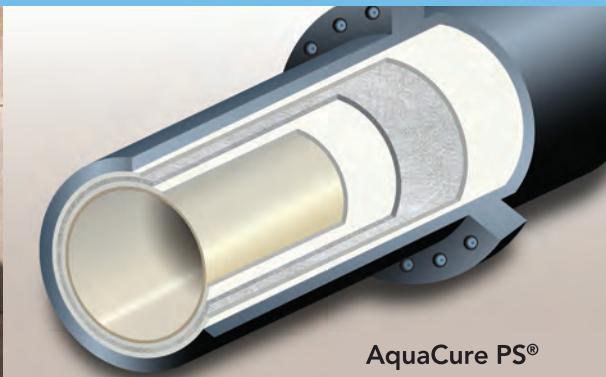

AquaCure PS®



# @mswmag.com

Visit the site daily for new, exclusive content. Read our blogs, find resources and get the most out of *Municipal Sewer & Water* magazine.



## BIRD'S-EYE VIEW

### Drone Provides Different Perspective

At street level, you get a compressed view of the trenches, equipment and activity around the project site. But rise above the buildings and the whole Downtown Rhinelander Streetscape Project unfolds like a living map. One local business owner's drone video will give you new perspective on this project. [mswmag.com/featured](http://mswmag.com/featured)

## OVERHEARD ONLINE

“ We've found a few enclaves, like fuel tanks, a number of mysterious rooms, old stairwells coming up in the sidewalk and things like that. ”

— *Project Team Adapts to Surprises*  
[mswmag.com/featured](http://mswmag.com/featured)

## PROJECT UPDATE

### Rhinelanders Renovation Hits Halfway Point

The city of Rhinelander, Wisconsin, has been in the midst of a \$10 million downtown streetscape project since early spring. In addition to combined sewer separation and sewer and water upgrades, there have been surprises, significant rain events and some project add-ons in the months since it started. The project was profiled in the August issue of *MSW*, and now you can get the update and a whole lot more online. [mswmag.com/featured](http://mswmag.com/featured)



## OUT WITH THE OLD

### Decades-Old Pipe Tells a Story

Aging infrastructure can cause plenty of problems. But despite its advanced age, Rhinelander officials took some positives away from the rusty pipe they dug up from the depths of downtown. [mswmag.com/featured](http://mswmag.com/featured)



## Emails & Alerts

Visit [MSWmag.com](http://MSWmag.com) and sign up for newsletters and alerts. You'll get exclusive content delivered right to your inbox, and you'll stay in the loop on topics important to you.



## Join the Discussion

Find us at:  
[facebook.com/MSWmag](https://facebook.com/MSWmag)  
[twitter.com/MSWmagazine](https://twitter.com/MSWmagazine)



# Because you never want to be left hanging...

## The stakes are high in pipelining.

Install the better option for your rehabilitation projects. Choose the turn-key technology provider that will be with you every step of the way.

- ☑ Engineering & Project Consulting
- ☑ USA Based Liner and Equipment Manufacturing
- ☑ State-of-the-Art Training Center and Installer Certification
- ☑ Quality Assurance with our Award Winning Quality Tracker System
- ☑ 24/7 Customer Service and Field Technical Support

## Work with a partner, not just a vendor.

Call or click today.

**RELIN**  
**AMERICA**<sup>™</sup>

866.998.0808

[www.relineamerica.com](http://www.relineamerica.com)





 **Next Generation camera systems feature Wireless Streaming Video to your WiFi equipped device via our MyTana Viewer App.**

**One Package does it all!**



**Includes:** **NGX10 Inspection System:** Next Gen color, self-leveling camera, 200ft push rod and the CBX17 control box  
**LD30 Leak Detector**

**RL8873 512 Hz Locator**  
Auto depth and direction indicators

**MSA-NG-PCAM:** Next Gen color, mini fixed-position camera, 100ft push rod

**PIPEHORN 800HL**  
Dual frequency locator

and more! Contact us at 1-800-328-8170 for complete details.

[www.mytana.com](http://www.mytana.com)

**800.328.8170**  
fax: 651.222.1739

**MyTana**

Contact us for your FREE full line catalog today!

CABLE MACHINES    JETTERS    PUSH CAMERAS FOR MAIN LINES & DRAIN LINES    LOCATORS    ACCESSORIES    RELATED PARTS

**MAKE THE CALL**

*Your*  
**HDPE Experts**  
Pipe • Fabrication • Fusion



For Details!



**1-800-353-3747 • [www.lesupply.com](http://www.lesupply.com)**

**353-3747**



**POLYMER MANHOLE LIDS**

Road Tested, Proven Quality  
**POLYMER LIDS**

**NEW POLYMER FRAME & LID ASSEMBLY**

**WATERWORKS SPECIALTY PRODUCTS TRUMBULL**

Call us:  
**800.677.1799**  
[trumbull-mfg.com](http://trumbull-mfg.com)

See for yourself at  
WEFTEC® 2016  
Booth #5321



# DUKE'S

## Sewer root control done right.™



**It's no coincidence our trucks are red.** When it comes to saving the lives of sewer pipes, count on Duke's Root Control experts to be there, on the spot, with the best product and service available. Our exclusive Razorooter® II is the only diquat-based herbicide registered by the EPA for controlling nuisance tree roots in sanitary sewer lines. But sewer root control done right means more than using the best products. Our trained professionals apply Razorooter® II, keep track of treatments, remind you when service is due, and save you money, time and effort. Best of all? Our work is guaranteed. With almost 40 years of experience we have helped cities keep their pipes healthy, prevent sanitary sewer overflows, comply with CMOM regulations and eliminate headaches and disruption. Call on Duke's to rescue your system from sewer pipe failures with our guaranteed products and services. **800.447.6687 | [www.dukes.com](http://www.dukes.com)**



 **DUKE'S**  
**ROOT CONTROL, INC.**  
Product. Service. Guarantee.

Visit us at WEFTEC Booth #4011



The New Mexico landscape provides a dramatic backdrop for Pueblo of Acoma Utility Authority Water & Wastewater Department employees excavating a water main. (Photography by Roberto Rosales)



# A COMMUNITY THAT WILL LAST

Pueblo of Acoma Utility Authority stretches limited resources to bridge historic past with a more modern future

By Peter Kenter

The Acoma Pueblo tribe of New Mexico has occupied the same land for more than 800 years, possibly as many as 2,000. While the word “Acoma” has many possible meanings, some tribal elders believe it means “a place that always was.”

The Pueblo of Acoma Utility Authority Water & Wastewater Department ensures that the community enjoys all of the benefits that modern technology offers, while respecting that long tribal history.

The community of about 5,000 is made up of several villages: Sky City (Old Acoma), Acomita,

Anzac, Skyline and McCarty’s. An appointed tribal administration and tribal council oversee the Pueblo. The population is relatively stable and the Pueblo’s economy benefits primarily from agriculture and tourism, rather than an industrial base.

The Acoma Pueblo tribe is a federally recognized tribal entity. Tribal governance is apparent in many aspects of utility operations. For example, tribal “ditch bosses” oversee the use of water for irrigation and gardens. In certain cases, the utility can benefit from grants or low-interest loans that are available to government-recognized tribes. The Pueblo of Acoma Historic Preservation Office

oversees all construction projects to ensure they exist side by side with a rich historic and cultural heritage (see sidebar).

Arvind Patel is the utility department director. With a background in environmental engineering, he came to Pueblo of Acoma in 2005 on a two-year contract to help clean up illegal solid-waste dump sites in the area. “I was able to secure a grant from the New Mexico Environment Department’s Recycling and Illegal Dumping Act Grant to recycle tires and use the crumb rubber to build the surface of a running track for the community,” he says.

*(continued)*



# Pipeline Technologies

## SFX 2D

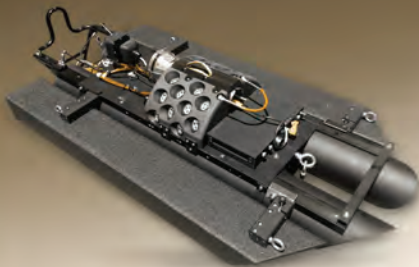

The CUES SolidFX 2D multi-sensor platform inspects pipeline diameters 15" through 200"+. The CUES Solid FX multi-sensor platforms, capable of distances exceeding 5,000', take the guesswork out of accurate data processing with their live view of Sonar, LiDAR, and HDTV, along with a camera and LiDAR lens clearing system.

**Eliminate the need for algorithms and estimations, due to droplets and debris interfering with the lenses, which, from time to time, create unusable data.**

\* CUES SolidFX 2D is marketed exclusively through PIPC

## CUES AMP™



The CUES AMP™ is a unique gyroscoically-based tool used to map the location of your pipe. It can be used in pipes sizes ranging from 1.5" to 96" and above.

Whether steel, concrete, HDPE, or PVC, this mapping system will provide info about a pipe's location, inclination (or sags), and internal geometry.

**The AMP™ tool with centralization, may be pulled either by a hand operated wireline or a mechanical winch. In certain cases, the tool may be pumped through the product line.**

## SFX 3D



The CUES SolidFX 3D multi sensor platform is used for condition assessment, re-habilitation, and geolocation mapping. For pipelines ranging from 36" to 240", deployed from a stable skid or tractor, the digital SONAR and DUC (fisheye camera) or traditional analog camera are complimented by 3D LiDAR.

**Never miss a defect with the DUC camera and collect high-density point clouds to accurately determine pipe size as well as corrosion and deformations.**

\* CUES SolidFX 3D is marketed exclusively through PIPC





**Left: Water and wastewater department employees excavate a water main to add new connections for nearby homes. Right: Limbert Martinez uses a Wacker Neuson soil compactor near a newly installed septic tank at a new office in the Pueblo of Acoma.**

### The utility is formed

The project impressed the tribal council, and Patel was hired on as

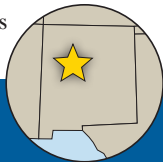

## PROFILE: The Pueblo of Acoma (New Mexico) Utility Authority Water & Wastewater Department

**YEAR ESTABLISHED:**  
Circa 1940

**POPULATION SERVED:**  
910 accounts/4,200 customers

**AREA SERVED:**  
27 square miles

**DEPARTMENT STAFF:**  
7

**INFRASTRUCTURE:**  
Sewer, 15 miles; water, 70 miles

**ANNUAL DEPARTMENT  
OPERATING BUDGET:**  
Approximately \$660,000

**ASSOCIATIONS:**  
New Mexico Water and  
Wastewater Association

**WEBSITE:**  
[puebloofacoma.org/Water\\_and\\_Waste\\_Water.aspx](http://puebloofacoma.org/Water_and_Waste_Water.aspx)

tribal engineer in 2008. He became the water and wastewater director in 2010 when the department began receiving dedicated and separate funding.

“Prior to water and wastewater forming its own department, Public Works handled almost every physical asset from water and sewer to windmills and maintaining fences for the ranching community,” Patel says. “At the time the department was formed, we started from scratch with myself, three other people in operations and maintenance and all of the knowledge they had in their heads about the system. Our first priority was asset management, and we went out and bought a GPS system, mapping all valves, hydrants and underground infrastructure using Esri GIS mapping software. We then married those to historic archival material, and now have digital maps for all underground infrastructure.”

Until August 2014, there were no fees charged for either water or wastewater services — these were 100 percent subsidized out of the pueblo’s revenues. “We enacted utility rates along with educating the public about the advantages of devoting additional resources to maintain and improve the system and to create a reserve fund,” Patel says.

Water is pumped from groundwater sources in the area’s sandstone aquifers. The water is treated with chlorine and SeaQuest (Aqua Smart Inc.), a chemical containing ortho- and polyphosphates that binds high levels of iron, manganese and hardness found in area water so they don’t particulate (fall out of solution) and scale on interior pipe walls.

The 70 miles of water pipe range from 2 to 12 inches in diameter and materials run the gamut from galvanized steel to asbestos cement, ductile iron and PVC. Most new construction employs PVC, either C900 or Schedule 40.

“Some parts of the system are up to 60 years old,” Patel says. “When the utility was formed we would have breaks quite often, up to several a month. We were spending more time fixing the breaks than doing preventive maintenance.”

One of the reasons for leaks is that the water system is spread out across widely varying hydraulic zones.

### Putting valves on automatic

“Back then, operators had to open and close valves manually rather than have the pressure controlled through pressure release valves,” Patel says. “Without having a complete picture of the entire system, this created a lot of pressure surges. We now have a floating system with PRVs, and the only time we manually switch the valves is when we exercise them.”

The utility has initiated a hydrant flushing program and has been monitoring pressure at various locations where repairs were turning into “Band-Aids on Band-Aids.” These pipes are being prioritized for replacement.

“After several years of repairs, creating a floating system, installing PRVs, and several pipe replacement projects, we’re finally on top of it, doing preventive maintenance and getting ahead,”

*(continued)*



VISIT US at WEFTEC  
BOOTH #2441

# Introducing Innovation: **ProSeries-M<sup>®</sup> MD-3**

THE HYBRID DIAPHRAGM CHEMICAL METERING INJECTOR

weftec 2016  
DIAMOND SPONSOR

Precision Chemical Metering  
for the Treatment of Municipal  
Water & Waste Water.

#### MD-3 Features Include:

- Hybrid diaphragm metering with best turndown in the industry at 2500:1.
- Smooth chemical dosing, no pulsation dampener needed.
- 50% more energy efficient – Patent pending design.
- Simple installation and setup with built-in controls. Drop-in-place.
- Built for long life at high pressures – No pressure regulator required.
- PVDF wetted end fittings allow for more than 14 inlet and outlet configurations.
- Zero maintenance brushless DC drive.

Multiple Patents Pending  
in the U.S.A. and UK

## Blue-White<sup>®</sup>

5300 Business Dr., Huntington Beach, CA 92649 USA • 714-893-8529  
sales@blue-white.com • www.proseries-m.com • www.blue-white.com





Pueblo of Acoma Utility Authority employees (from left) Arvind Patel, Marc Jaure, Lloyd Shutiva and Raymond Abeita.

## DESIGNED WITH TRADITION IN MIND

The Pueblo of Acoma's Sky City, also known as the Old Acoma Village, is an ancient Native American ancestral village built on top of a 400-foot mesa, the home of what is possibly the oldest continuously settled community in the country.

Sky City aims for tradition and authenticity, but it's also a popular tourist destination. When the community elders requested a new washroom facility for guests, they turned to the Pueblo of Acoma Utility Authority Water & Wastewater Department to craft a solution that would combine modern technology with a noninvasive approach to heritage.

"In the interests of heritage, there are no water or sewer utilities up in the old village," says department director Arvind Patel. "The request put to us was to create clean and sanitary washroom facilities for as many as 100,000 visitors per year while still preserving both the aesthetic and historical nature of Sky City."

With the assistance of Advanced Composting Systems LLC, the department developed an off-grid washroom facility that relied entirely on rooftop solar panels for its lighting.

"These washroom facilities are 100 percent off-grid waterless composting restroom buildings," Patel says.

The 12-building washroom facility with 71 individual stalls and two showers was built with grants from the EPA, Indian Health Service and the State of New Mexico totaling about \$3 million. The facility is accessed from a second-floor skyway extending from the mesa. That allows generous space for the composting facility on the base level, which takes up about two-thirds of the height of the building.

"It was designed with an exterior that gives it a traditional stucco look," Patel says. "It was a great wastewater solution that respects tradition and preserves the Historic Preservation status."

Patel says. "We experienced only one break over the entire winter last year."

### A newer sewer system

The 15 miles of sewer line is composed of clay and PVC.

"The sewer system was put in over the past few decades, so there are not a lot of issues, except some root intrusion," Patel says.

About half the community is still served by individual septic systems. While the sewer system continues to slowly expand, construction is problematic because in many areas crews have to dig through hard rock to lay new pipe.

"In other areas, complicated elevations make it difficult to engineer proper gravity flows," Patel says. "For now it's more efficient for us to offer septic pumping as part of our utility service."

The utility currently operates one septic truck — an International with a 3,500-gallon tank by Lely Tank, outfitted with a 3,500 psi jetter.

The utility performs repairs on both water and sewer pipes, up to complete full-circle breaks and pipe replacement. The crew also replaces hydrants and components and handles other repairs. Larger construction projects are contracted out.





Lloyd Shutiva collects a sludge sample from the Pueblo of Acoma wastewater treatment plant.

ment we manually conduct three field tests for ammonia, nitrates and 30-minute settleability. Using those three simple tests we can make any adjustment we require and ensure we don't exceed our permits. We're not spending taxpayer money on expensive equipment we don't really need to perform process control testing."

Despite its limited resources, the utility has achieved professional recognition. At the 2015 New Mexico Water and Wastewater Association award ceremony held earlier this year, the utility took home both the Water System of the Year

award and the Max Summerlot Award for wastewater treatment. Employees also took home two of four Operator of the Year awards: Jessie Padilla for wastewater operator and Marc Juare for water.

"We may be a small utility but we take our responsibilities seriously," Patel says. "At the end of the day that means quality drinking water and an effective wastewater system. By also promoting conservation and efficiency, we can ensure that the future generation of the Pueblo of Acoma will inherit a self-sustaining system that protects both cultural resources and quality of life." ♦

### Bringing maintenance in-house

Currently, the utility hires a third party for sewer line maintenance, but that function is being brought in-house this year.

"We're looking to obtain a Vactor 2100 in late 2016," says Patel. "We're also looking at buying a sewer line camera. That will really expand our capabilities."

Wastewater treatment is provided courtesy of two lagoon systems and a sequencing batch reactor activated sludge plant.

"As a small utility we're always looking for efficient ways to stretch our resources," Patel says. "We prioritize our needs. The SBR system runs largely through automation, but instead of buying expensive automated effluent testing equip-

# Red Valve

Visit Us at WEFTEC, Booth # 2639



- WATER
- WASTEWATER
- CHEMICAL
- POWER
- MINING

**The Professional's First Choice for the Toughest Applications.** Solving your most demanding flow control applications – this has been the single, driving force at Red Valve since our founding in 1953. Red Valve is the world's largest manufacturer and supplier of pinch valves and check valves and is the preferred provider for municipalities and industrial plants worldwide. Call us to find out how we can help solve your toughest challenges today.

### FEATURED PRODUCTS FROM:

**Advanced Composting Systems LLC**  
406/862-3854  
www.compostingtoilet.com

**Lely Tank & Waste Solutions, LLC**  
800/367-5359  
www.lelytank.com

**Aqua Smart Inc.**  
404/696-4406  
www.aquasmartinc.com

**Vactor Manufacturing**  
800/627-3171  
www.vactor.com  
(See ad page 3)

**Esri**  
800/447-9778  
www.esri.com

**Wacker Neuson**  
800/770-0957  
www.wackerneuson.com

Tideflex®  
Check Valves



CheckMate® In-Line  
Check Valves



Control Valves



Knife Gate Valves



Manual Pinch Valves



www.redvalve.com | 412.279.0044







## The Solution

### CAN'T FIND A LEAK?



### POWER SMOKER™

- Quickly and safely locate leaks in indoor plumbing systems (sewer line tester shown above)
- Uses the ONLY tested safe smoke on the market

### TOUGH VALVES?



### Spin Doctor

- Several options available to cater to the specific needs of your city
- All booms come with a LIFETIME WARRANTY

### RELIABLE WATER SUPPLY?



### FireFlow Pro

- The most accurate method available for flow testing activities
- Options vary from small communities that only want inventory options, to large cities needing GIS solutions

VISIT OUR NEW WEBSITE:

**HURCO**TECH.com  
800-888-1436



## MACHINE WORKS INC.

Your rotating equipment professionals

Western Canada's leading provider of certified repair, overhaul and refurbishment for all types of mechanical and rotating equipment. This includes blowers, gearboxes, pumps, mixers, fans and heavy industrial machinery.

- PD BLOWER SALES AND REPAIR
- GEARBOX SALES AND REPAIR
- PUMP SALES AND REPAIR
- DYNAMIC BALANCING & VIBRATION ANALYSIS
- FIELD & MECHANICAL SERVICE
- WELDING & FABRICATION

Authorized Howden Roots™ Blower distributor, service and warranty centre for Alberta & Saskatchewan



Authorized warranty and field service center for Hayward-Gordon, Sharpe Mixers & Scott Turbon Mixers in Alberta.



**OUR TEAM IS READY TO ASSIST YOU!**  
**+1 (587) 521-7544**

#300, 5715 76th ave NW, Edmonton, AB, Canada  
 p: +1 (587) 521-7544 e: info@xceedmachine.ca  
 f: +1 (587) 521-8656 w: xceedmachine.ca



Beyond buckets and blades.

**digDIFFERENT**

**FIND OUT HOW.**  
FREE subscription at digdifferent.com





Spartan Sparshine™ Cable



Cable Ends & Root Cutters



Spartan Model 1065

## That's why I buy Spartan!



John Proctor  
Cool Blew Plumbing  
Serving the Phoenix, AZ area

## Why do YOU buy Spartan?

Spartan equipment is built to conquer the toughest clogs - roots, grease, hair - whatever your customers can throw down the drain.



**SPARTAN**  
FOR TOUGH CUSTOMERS.  
SINCE 1943

COME SEE US AT:  
**WEQFAIR**  
MILWAUKEE

### *The Spartan Advantage*

Our Territory Managers come to you.  
We provide sales, service & training,  
all at your site. Call today to schedule a visit!

[www.SpartanTool.com](http://www.SpartanTool.com)

800.435.3866

Have a great picture of a root you conquered with your Spartan machine? Send it to us at [TellUs@SpartanTool.com](mailto:TellUs@SpartanTool.com).



# THE FACTS ABOUT FEEDBACK

Regularly asking for and receiving candid performance evaluations is a developmental tool every employee should master

By *Ken Wysocky*

Most workers dread performance reviews, which more often than not are tedious and non-productive exercises. So imagine what jobs would be like if employees received a mini appraisal, say, every week. Or even daily. And for the real kicker, what if these employees liked the reviews so much they requested them?

If that sounds like the workplace from hell populated with gluttons for punishment, guess again. In reality, consistently asking for — and gracefully receiving — feedback is a powerful tool for not only career advancement, but greater job satisfaction and engagement, says Beth Wagner, a master facilitator at Fierce Inc., a leadership-development consulting firm ([www.fierceinc.com](http://www.fierceinc.com)).

During a webinar sponsored by the Human Capital Institute ([www.hci.org](http://www.hci.org)), Wagner notes that regular and consistent feedback can be much more worthwhile to employees than annual reviews. But the shame of it is that while it's both a valuable and critical leadership competency that every employee should master, it's also highly underutilized — an under-the-radar solution to much of what ails organizations in terms of disengaged employees and high turnover rates.

In fact, one survey showed that companies encouraging regular employee feedback recorded 15 percent less turnover than companies where employees don't receive regular feedback. Moreover, another study shows that the best leaders in business regularly ask for feedback, which clearly indicates it's a valuable skill.

But if feedback is so important, why isn't it used more often as an employee development tool? The truth of the matter is that asking for feedback is a frightening prospect for many employees, Wagner explains. After all, it's only human nature to want to hear just good things — and an honest assessment of your performance very well could reveal you're not the superstar you believe you are. Furthermore, providing candid feedback is also hard for many managers; more often than not, they'd rather steer clear of conflicts.



**We invite readers** to offer ideas for this regular column, designed to help municipal and utility managers deal with day-to-day people issues like motivation, team building, recognition and interpersonal relationships. Feel free to share your secrets for building and maintaining a cohesive, productive team. Or ask a question about a specific issue on which you would like advice. Call editor Luke Laggis at 800/257-7222, or email [editor@mswmag.com](mailto:editor@mswmag.com).

So what can Joe and Jane Employee do to get a seat on the feedback train? Wagner says the following five tips will jump-start the journey.

**1. Start asking for it.** Remember the old adage about ask and you shall receive? The same is true for feedback.

Too many people wait for feedback to occur naturally; they figure if they're doing something wrong, they'll hear about it sooner or later.

But as anyone can tell you who's been sideswiped during a job review by unexpected performance criticism, that's not always the case.

Keep in mind, however, that just asking for feedback is not enough. Or as Wagner put it, general questions — such as “How did I do?” — will typically lead to general answers. The key is to ask your supervisor about specific areas of your performance, such as what you can do to communicate more effectively with your team, for example. In addition, don't ask for feedback from someone who you know is more likely to praise you than provide an honest assessment. The latter is much more likely to help you improve, no matter how much it might hurt initially, she says.

As for people who say they always ask for feedback, but never receive any, Wagner has her doubts. “I don't believe that,” she says. “If you're asking for feedback and not getting it, I'd be asking myself some harder questions ... about why people won't share tougher things with me.” Perhaps you need to build more trust — think about how the conversations you have play a role in discouraging honest feedback, she says.

**2. Listen and learn.** Asking for feedback leaves you vulnerable to hearing things that may not match your own perceptions. As such, it's important to be prepared to hear some hard truths and not overreact; instead, be open to exploring those issues in more depth with the feedback provider.

While you do so, Wagner says it's critical to remember that when people speak, they are generally confirming what they already know, but when



they listen, they learn something new. So put on your listening hat and get ready to learn, she advises. That involves suspending any perceptions you have of yourself and keeping an open mind about what the feedback provider is trying to convey. Also think about what you could learn and what impact it might have on your performance or career, she adds.

**3. Remain curious.** This tip goes hand in hand with listen and learn. Too often, we're quick to dismiss things that don't fit our own perception. But instead of getting defensive, switch into what Wagner calls "curiosity mode." Dig deeper into their perceptions of you and/or your performance. Ask the provider for information and examples that support his or her perception. It's OK to express surprise at a provider's comments, as long as you keep probing for supporting information. And if the feedback truly is shocking to you, it's perfectly OK to ask the provider for some time to think about it and agree to talk in more detail later.

**4. Be open-minded.** It's important not to jump into defense mode if you hear something you don't agree with. While Wagner concedes that's easier said than done, she notes that if you truly want feedback, it's important to accept others' perception of you. Moreover, people who respond well to feedback are looked upon favorably and generally have higher emotional intelligence, she notes.

The beauty of getting feedback is you have a choice about what to do with it. In fact, you don't have to do anything at all in response to negative feedback, Wagner explains. "But you should understand that if you ask for feedback and do nothing, it's often worse than not asking for feedback at all. ... It looks like you're not taking it seriously," she says.

Since changing behaviors is hard, it's also OK to work incrementally and make small changes over time, as opposed to trying to do everything the provider suggested all at once. "You also can decide to change only certain things, not everything the provider suggested," she points out. "But either way, it's important to let the provider know what you're going to do."

And if you're not going to do anything at all, it helps to sit down with the provider and explain why. Why? It helps to build the relationship, Wagner says.

**5. Say thank you.** In a nutshell, Wagner believes that greater respect leads to greater results. And part of being respectful means repeating those two magic words that most of us learned as children: thank you. As noted before, it's not always easy for managers to provide candid feedback. And by pro-

viding you with powerful feedback, the provider is taking a risk by assuming a partnership role in your success.

"You can take it or leave it (the feedback)," Wagner says. "But your job is to always remain grateful for whatever you get. That paves the way for more meaningful feedback because trust has been built." ♦

# Let There Be Light. UV Light.

**We didn't invent light, but we are  
mastering innovative ways to  
use it.**

UV Light-Cured CIPP  
from Inliner Technologies.

**inliner**  
REINFORCED UV-CURED LINER **STX**

[www.inliner.com](http://www.inliner.com)

© 2016 Inliner Technologies

  
**inliner**  
technologies™



# 125 MILLION IMPACTS



weftec 2016  
Booth 1319

## ZERO INFLOW

Make a positive impact on your bottom line with PRO-RING™, the most advanced concrete-alternative manhole grade adjustment system available today. Installed on tens of thousands of manholes and catch basins throughout the U.S. and Canada, these lightweight rings are renowned for their exceptional strength-to-weight ratio, durability, chemical resistance and long service life under the most demanding conditions.



800-345-3764 info@cretexseals.com  
www.cretexseals.com

## The SNOUT® and the SAFL Baffle™ A Perfect Pairing for your Menu of BMPs



Get Trash, Oil and verified T.S.S. removals with the SNOUT, Bio-Skirt® and SAFL Baffle



Best Management Products, Inc.  
bmpinc.com • 800-504-8008

The SAFL Baffle is a patented and trademarked product of Upstream Technologies, Inc., an OEM supplier to BMP, Inc.

## ADVANCED WATER LEAK DETECTOR



The LD-18 Digital Water Leak Detector uses patented technology to significantly reduce ambient noises from dogs barking, footsteps, people talking, etc. The digital amplifier samples the sounds every few tenths of a second, rejecting intermittent sounds instantly.

See the LD-18 at [www.subsurfaceleak.com](http://www.subsurfaceleak.com).

 SubSurface Locators™

(408) 249-4673  
[www.subsurfaceleak.com](http://www.subsurfaceleak.com)

weftec 2016  
Booth 5522



**CAMEL 1200**  
**12 YARD SEWER CLEANER**

# CAMEL SAVES

**WATER • TIME • MONEY**



### **SAVE WATER!**

Clean 2,500 feet of pipe a day; save 50,000 gallons of water a week.  
Good for productivity. Good for the environment.

### **SAVE TIME!**

Longer on-site performance. Clean 78% more pipe a day.  
That's like adding two more days to the five day work week.

### **SAVE MONEY!**

Saving water, saving time: Saves money.  
Double your profits. Pay your unit off in months.



*Living up to our name.*

800.837.9711 • [www.superproductsllc.com](http://www.superproductsllc.com)

COME SEE US AT:  
**WEQFAIR**  
Water & Environmental Expo  
**MILWAUKEE**

View the video. Request your demo today!

[www.camelsaves.com](http://www.camelsaves.com)



# BETTER THAN THEY FOUND IT

Pennsylvania utility emphasizes longevity and takes a proactive approach to system setup and maintenance

By Mary Shafer

The southern border of York County, Pennsylvania, is the Mason-Dixon line, separating it from Maryland. Rich in history, the area saw more than a little action in the American Civil War, but now a different kind of skirmish is happening.

As the Washington, D.C., beltway region and Greater Philadelphia both expand, this rural area is becoming more densely populated. Now a bedroom community to these major metro areas, York County is experiencing a battle to maintain its traditional character against the onslaught of developers eager to profit from the current population boom.

Windsor Township is one of the communities here grappling with responsible development. While its board of supervisors sorts out ordinance issues and regulatory compliance, Director of Public Works Jeremy Trout feels a different kind of obligation. He sees the new infrastructure going into the ground to service burgeoning development as an opportunity to take a proactive approach to system setup and maintenance.

As new gravity lines and force mains are extended from existing systems, his department has the chance to rehabilitate sections of the old infrastructure that are failing due to age. That's to be expected, but Trout's attitude about the new assets is what's less common these days. Whereas many responsible for funding, planning and implementing maintenance are only concerned with what happens during their tenure, Trout doesn't believe in kicking that can down the road.

"The guy in my position 45 years ago didn't think of me and what I'd have to deal with," he says. "But I am thinking of the guy 25 years from now, who will be having to deal with rehabbing these pipes."

## Planning ahead

Trout came by his attitude naturally. He believes there's a right way to do things, and is determined

*(continued)*



Public Works Director Jeremy Trout at the Panorama Hills Pump Station in Windsor Township, Pennsylvania. (Photography by James Robinson)



# Trio Vision LLC Acquires Cobra Tech



**Custom Built  
Vehicles, Trailers, ATVs**



## Fast, User Friendly PACP Software

- > PACP, MACP, LACP Certified
- > Touch Screen
- > Quick Easy Entry
- > Grout Inspections
- > PACP Exporting
- > Inspection Reports with grading
- > Pipe Graphic Report
- > Image Report
- > Cobra View Export
- > Affordable Upgrade to GIS, Asset Management Modules

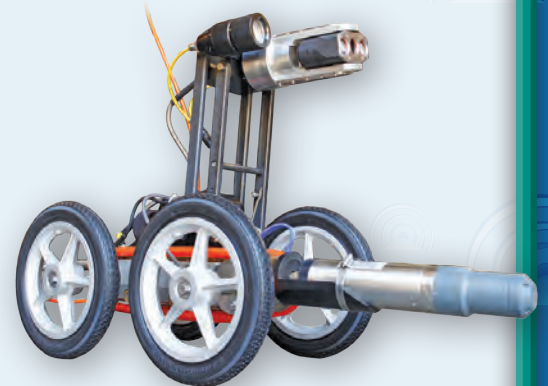

## Sonar Long Line Available up to 6000 ft

## NEW PRODUCTS INCLUDE:

- » **Portable Steerable Crawlers System**
- » **Manhole Camera**
- » **Jet Cam**

Contact our sales department at: 800-443-3716

**Cobra Technologies** is an authorized installer for the **Schwalm Robotic Cutter** system. Integrated Solutions utilizing the Cobra mainline system for a dual purpose inspection and Schwalm cutting/lining ready vehicle.

## Other Available Systems:

- > Rental Vehicles, Monthly or Yearly
- > Used Vehicles for Purchase
- > Used Inspection Vehicles
- > Used Grout Trucks
- > Used Lateral Inspection Systems
- > PACP Certified Software and Hardware for Rent



So Advanced... It's Simple!



**800.443.3761**  
**770.435.8991**

[www.cobratec.com](http://www.cobratec.com)





**Troy Dehoff checks and cleans pump seals at the Panorama Hills Pump Station, which was built to serve a new commercial and residential development.**

to do them that way. This view was nurtured by his experience repairing sewage systems, when he worked with his father's construction company.

"I always wondered why people didn't do a better job of planning ahead, to be more helpful in making repairs and maintenance not as hard. Why not do a better job designing, so it's easier? There's always a right way to do things and a way to just get it done. I wanted to do it right."

When he was first hired by Windsor Township 14 years ago, Trout looked at all its infrastructure, underground and above. "There was the usual attitude of only fixing things as they broke," he explains. "We had some lift stations that were 40 years old, and we were holding on to some dinosaurs that should have been replaced even before I got here."

When he started to explore the condition of these pump stations, what he found disturbed him even more. "Our area is really hilly and causes a piggyback effect. Every time the force main dumps into a gravity system, it stirs up the sulfide gases, releasing them into the gravity lines, which are asbestos concrete. Anything above the waterline gets attacked by those gases and deteriorates. Over years of no one really looking into this, our system was being eaten alive." It was then he decided to take

a proactive approach to system maintenance.

So, when the township created its Act 537 Plan — a required local ordinance in Pennsylvania that addresses existing sewage disposal needs and planning to prevent future problems — in 2005, Trout brought his forward-looking stance to the table. They looked into what was needed to open up sewer capacity for coming development.

Bob Ward Companies, a builder from Maryland, owned 113 acres in Windsor Township and wanted to develop a mix of commercial properties and residential townhomes in an area of the Kreutz Creek Valley they named Panorama Hills. State DEP regulations require municipalities to provide service infrastructure to areas with potential for development, so the township had to initiate a capital improvement project in 2006-07.

"I worked closely with our township engineer, C.S. Davidson, on the whole project and was involved in its design," Trout recalls. "We took a hard look at what we didn't like about the old system, and were determined to change it."

### Things get real

The economic crash of 2008 put the project on hold until 2013, when it was resurrected. After reviewing the developer's plans, it was determined

### PROFILE:

## Windsor Township (Pennsylvania) Public Works



**POPULATION SERVED:**  
18,000

**AREA SERVED:**  
Windsor Township and  
the residential areas of Red Lion

**STAFF:**  
17

**RAW WATER SOURCE:**  
Red Lion city water (half),  
York city water (half)

**INFRASTRUCTURE:**  
400,000 feet sewer main, 26 laterals,  
24 pump stations, 2,600 manholes

**WEBSITE:**  
[www.windsortwp.com](http://www.windsortwp.com)

that the township would need to install 2.5 miles of new gravity sewer main running to the Panorama Hills pump station, including 3,600 feet of 21-inch-diameter pipe, 6,500 feet of 18-inch, 3,000 feet of 15-inch, and a little over 700 feet of  
*(continued)*



# PREVENT OVERFLOWS

Lowest Cost Sewer Level Monitoring System



**MONITOR**<sup>TM</sup>

- Detect blockages early
- Eliminate customer complaints
- 10 minute surface installation
- Intrinsically safe

**weftec** 2016  
the water quality event™  
**BOOTH 5139**

**ADS**<sup>®</sup>

**WHEN OVERFLOWS MATTER - ADS MONITORS!**

[www.adsenv.com/echo](http://www.adsenv.com/echo)





**Scott Elfner takes down readings at the Panorama Hills Pump Station.**

8-inch. The latter connected existing lines to an existing interceptor, which was a combination of PVC and ductile iron, where the line runs under Kreutz Creek four or five times.

They also needed to upgrade the same length of 16-inch force main running out of the pump station, which would be laid parallel to the gravity line, 8 feet apart. Stubs for commercial properties and 26 laterals for several residential homes would need to be installed, with 58 manholes constructed to service these lines.

The aging pump station was already under-

sized, having been designed for rural farmland. It would provide woefully inadequate capacity for future service to the major retail shopping district that had been approved, and the higher-density housing that will ultimately surround it. The old station was abandoned, with the replacement built right across the street.

In total, the Panorama Hills Interceptor Venture project would cost \$12 million. Trout wasn't about to allow any of the value of that significant amount to be jeopardized on his watch. He made sure the design included capacity in excess of 1

million gpd, far greater than the 100,000 gpd currently running, so that today's investment could be counted on for service far into the future.

The design was tweaked to avoid problems they were having with two older stations. One large wet well was partitioned, so one side could be shut off for cleaning and repairs without having to shut down the whole station.

To ensure these 24-foot-long by 12-foot-wide and 11-foot-deep rectangular wells would last as long as the building housing them, they were lined with Sprayroq Spraywall to the top of the waterline, then with Sprayshield Green from the waterline to the top of the wall. The work was done by Abel Recon of Mountville, Pennsylvania, the project's general contractor.

**The Windsor Township Public Works team includes (from left) James O'Dell, Jeremy Trout, Troy Dehoff and Scott Elfner.**



### Down the road

Trout made sure several other improvements were made in this new pump station, which will pump sewage from the bottom of the valley up over a hill to a main trunk that takes it to the Springettsbury Township wastewater treatment plant.

"In the old stations, when we had to remove pumps from two stories down, we had to take the steps out to do it. In this one, we designed it so we could open a metal hatch outside and lift the pumps or motors out through the hatch, instead of having to move structures around inside of the vault."

They also built in a pump port that allows pumping from the station directly into the force main if the station is shut down for any reason. A climate control system was included to keep humidity down, eliminating corrosion of controls and equipment caused by sweating inside the building. This represented more cost savings down the road.





**James O'Dell inspects pump station equipment.**

Trout had long been using Sprayroq's polyurethane foam liner products for other projects and knew he could count on its protective qualities for the pump station's new wet wells, and he also wanted to use its Spraywall liner in all the new manholes both for its protective and structural qualities.

There was a logistical challenge to this part of the job: Flows couldn't be interrupted. Performing a bypass would have required a very large, expensive pump, and would have been very time-consuming. This would have prolonged the entire project, which was already being slowed by the weather.

### Fresh thinking

Abel Recon project manager Lowell Mummau decided that instead of trying to bypass, it made more sense to build a new manhole around the existing one, then remove the old one once the new one was finished. Because they only needed one day to build each manhole, this was accomplished using what Abel calls its "flow-through" method.

The crew put an inflatable plug in the upstream side of the manhole and allowed controlled flows through the bottom of it through a smaller pipe, restricting the flow into the outflow

downhill. This allowed them to then continue with spray lining, since no water was collecting and creeping up the walls. "Exposure to failure and a bunch of other problems were nearly eliminated this way," Mummau recalls.

Several bypass and pressure vaults on the force main — averaging 12 by 10 by 8 feet, with a few deeper — were injection pressure grouted, then also sprayed with 125 mils of Sprayshield Green.

Trout encountered no resistance when asking for funding for his more expensive, proactive construction program approach. "The

supervisors didn't really bat an eye. No one felt anything we asked was extravagant. We got no pushback out of the ordinary," he says, believing that his bosses understood the wisdom of his long-term thinking.

"You might as well do (preventive lining) when it's brand new, and the easiest time to do it. If you wait until later when you start having problems, it will be more expensive, difficult and disruptive ... and it's still going to need to be done." ♦

the single solution  
for pipeline inspection  
from drainlines to  
storm drains...





and everything  
in-between.

Call or click today  
for a field demo of our  
single conductor CCTV  
pipeline inspection technology.

cameras | tractors | vehicles | systems



Design and Manufacture of Video Pipeline Inspection Systems

conductor

THE SINGLE SOLUTION



#1500

800.767.1974 [rstechserv.com](http://rstechserv.com)

#### FEATURED PRODUCTS FROM:

**Sprayroq, Inc.**  
205/957-0020  
[www.sprayroq.com](http://www.sprayroq.com)



**weftec**<sup>®</sup> 2016  
the water quality event™  
COME VISIT US AT BOOTH #4516

## WASTEWATER SOLUTIONS FROM BEGINNING TO END



### COLLECTIONS • HEADWORKS • SLUDGE

#### JWC ENVIRONMENTAL HAS YOUR SOLIDS REDUCTION AND REMOVAL SOLUTION

Wipes clogging lift station pumps? Muffin Monster<sup>®</sup> grinders with Wipes Ready™ technology will break down rag balls and keep pumps flowing.

Need fine screening at your headworks? JWC's Monster Screening Systems will stop the smallest debris with perforated plate screens and IPEC™ Drum screens. Discharge debris directly into a Screenings Washer Monsters to launder, compact and dewater screenings.

Searching for sludge solutions? IPEC™ Rotary Sludge Thickeners from JWC Environmental and Muffin Monster sludge grinders keep sludge systems on top of their game.



Contact Us Today For More Details  
toll free: 800.331.2277 | phone: 949.833.3888  
email: [jwce@jwce.com](mailto:jwce@jwce.com) | web: [www.jwce.com](http://www.jwce.com)

# RTO

[www.RentalToolsOnline.com](http://www.RentalToolsOnline.com)

**Worldwide Sales and Rentals**

pipe plugs to 10'  
controllers  
hoses



[www.RentalToolsOnline.com](http://www.RentalToolsOnline.com)

## America's Trench Box Builder™ Efficiency Production, Inc.

### The Public Works Professional's Choice for Shoring & Municipal Equipment Nationwide!

- Largest selection of shielding & shoring equipment available
- Custom built shields
- Site-specific engineering
- Job site installation assistance
- OSHA Trench Safety Training

Our extensive Dealer network and factory-direct Sales & Rentals combine to supply the entire United States with fast delivery and excellent service.



Municipal Trench Shields



Build-A-Box™



Hydraulic Shores



Alum-A-Shield™

Toll Free for your local dealer or  
Factory Direct Sales & Rentals

**800-552-8800**

[www.encyproduction.com](http://www.encyproduction.com)  
685 Hull Rd., Mason, MI 48854

**EFFICIENCY**  
**PRODUCTION, INC.**  
America's Trench Box Builder™



## Optimum productivity is standard – not an option

High performance Vacall vacuum and jetting machines are easy to operate as they deliver greater productivity, superior vacuum power and stronger jetting forces. Because productivity is critical, AllSmartFlow smart controls are standard – not an option. And we respond to your need to save money and reduce emissions by designing machines that use just one engine and with standard and optional lifetime warranties on water and debris tanks. For greater return on investment, choose the versatile workhorses that are designed, built and supported by Gradall quality.

Call 800-382-8302 to learn why  
nothing works like a Vacall.

**AllExcavate**



**AllSweep**



**AllVac**



# POWER HITTERS

**AllJetVac**



Never stop for refills with the  
**RECYCLER** continuous  
water recycling option.

COME SEE US AT:  
**WEQFAIR**  
Milwaukee Equipment For  
MILWAUKEE

[VACALL.COM/POWERHITTERS](http://VACALL.COM/POWERHITTERS)





# RUNNING ON EMPTY

Water-recycling vac trucks could eliminate the use of potable water for cleaning sewers

By Ken Wysocky

A small group of early-adopter contractors is using new water-recycling vacuum trucks to clean sewer lines. If adopted on a large scale, the technology could potentially save municipalities voluminous amounts of water a year — an especially attractive benefit for drought-stricken regions — as well as reduce sewer cleaning costs.

Manufactured by J. Hvidtved Larsen A/S in Denmark, the RECYcler water-reclamation vacuum trucks are currently being used in California, Ohio and along the East Coast. Already popular in Europe, the RECYclers operate like normal vacuum trucks, with one glaring exception: They don't need to fill up with potable water in order to work. Instead, the truck removes water from debris it sucks from sewer lines, then cleans it and reuses it for waterjetting.

"The municipal officials who have seen how this truck performs have a high appreciation for its benefits," says Jim Lounsbury, executive vice president of National Water Main Cleaning Co., based in Kearny, New Jersey. The company runs about 70 conventional vac trucks along the East Coast, mainly for municipal sewer cleaning, and owns two RECYcler 315s, one based in Kearny and one in California. "The RECYcler is almost like a potable water treatment plant."

It's difficult to quantify exactly how much water the RECYclers save per job. But John Sullivan, the sales and customer support manager for J. Hvidtved Larsen's operations in the U.S., estimates that the unit can save about 20,000 gallons of water per day compared to a conventional vacuum truck. Lounsbury points out that a traditional vac truck with an 80 gpm water pump that runs for six hours a day could use nearly 30,000 gallons of water.

But no matter how one extrapolates the numbers, the water savings could

be substantial if the technology is adopted nationwide. "From a conservation perspective ... think about the people in California who eat off paper plates because they don't want to use water to wash dishes," Lounsbury says. "I think the ability to reuse sewer water to clean pipes and not tap into that valuable freshwater resource represents the future of the industry."

Water-recycling vac trucks could also reduce operating costs for municipalities because sewer cleaning contractors won't be taking potable water from fire hydrants, using it to clean pipelines, then putting it back into the system to get treated again. "You're saving taxpayers the cost of reprocessing clean water," Lounsbury points out.

"There's a cost savings there for municipalities," says Brandon Long, a civil engineer for Burgess & Niple, an engineering and architectural company that works with water and wastewater utilities. Long has seen the RECYcler technology in action twice during the last year and came away impressed. "When contractors pull treated water (from a hydrant), there are costs associated with treating that water before it's used," he says. "And if you treat water to make it safe to drink, it's a wasted expense if you don't use it for that purpose. Then you pay to treat it again (after it's used for jetting).

"But when you pull water from a sewer, the water has at least already been used," he adds. "So the benefit is similar to any other form of recycling — you're getting a second use out of it."

Another potential benefit: Contractors will be able to clean more linear feet of sewer per day, and that enhanced productivity could reduce sewer cleaning expenses for municipalities. Where does that efficiency come from? Instead of wasting time going back and forth to fire hydrants to refill vac trucks' water tanks, contractors can spend all day on a job site, never leaving to refill a water tank. Keep in mind that most vac truck pumps generate flow of 80 to 120 gpm. So with an 1,800-gallon tank, a truck can run out of water in about 15 minutes. "You're lucky if you can clean 250 feet of line in that 15 minutes," Lounsbury says.

National Water Main workers find access to hydrants is becoming more and more limited, which means operators must run back and forth to public works departments to fill up, Lounsbury says. "It could be a 5- or 10-mile trip from a job site, depending on the size of the community," he says. As such, operators might lose two to three hours a day running for water instead of performing productive work, he notes.

"We've seen productivity of up to 3,000 feet (of pipe cleaned) per shift with the RECYcler versus 2,000 feet per shift with a two-man crew and a traditional vac truck that needs to make runs for more water," he says. "The pro-

## BETTER MOUSETRAPS

**PRODUCT:**  
RECYcler 315 water-reclamation vacuum trucks

**MANUFACTURER:**  
J. Hvidtved Larsen A/S  
312/705-3818  
www.hvidtved.com

**APPLICATION:**  
Cleaning sewers

**BENEFITS:**  
Save municipalities voluminous amounts of water; reduce sewer cleaning costs

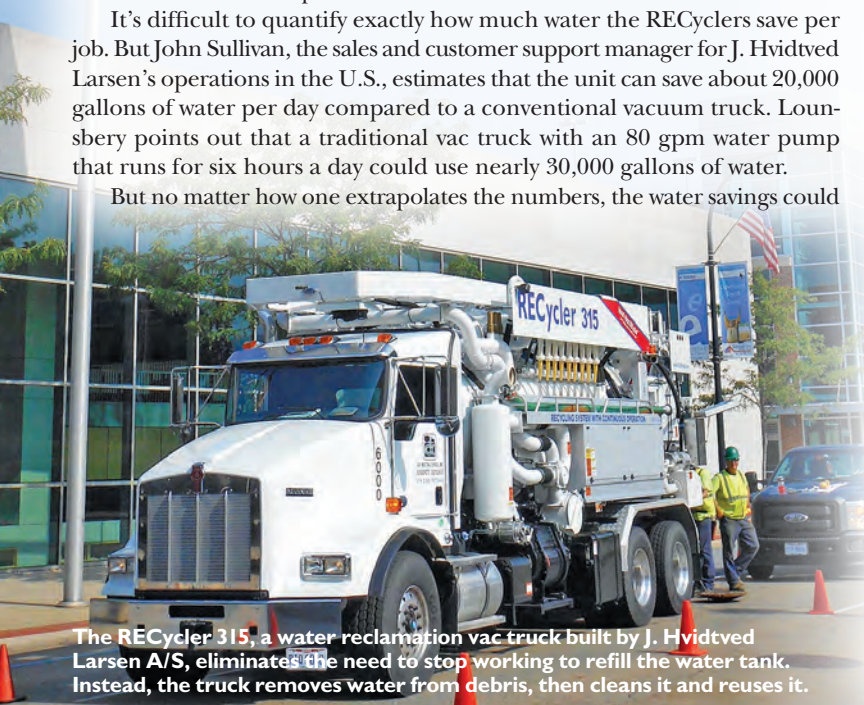

The RECYcler 315, a water reclamation vac truck built by J. Hvidtved Larsen A/S, eliminates the need to stop working to refill the water tank. Instead, the truck removes water from debris, then cleans it and reuses it.



ductivity increase is truly significant.”

Lounsbury notes that the RECYcler enables contractors to use manpower more efficiently, which also reduces costs. For example, a RECYcler requires just one operator, while a traditional vac truck might require an operator, plus another worker to drive a water truck to a job site if the designated hydrant is so far away that refills become costly and inefficient.

“All those inefficiencies drive up costs for municipalities and eventually taxpayers in those communities pay for those costs,” he explains. “The bottom line is I can bid on jobs cheaper because of the RECYcler, so municipalities save money.”

Ohio-based C&K Industrial Services Inc., which offers industrial and municipal cleaning services, bought a RECYcler 315 about a year ago after seeing one at a Water & Wastewater Equipment, Treatment & Transport Show, says Henry Sorensen, the company’s fleet manager. The unit features

a 2014 Kenworth T-800 truck chassis; a water pump made by URACA (124 gpm at 2,175 psi); a vacuum pump made by CVS Engineering (1,825 cfm at 25 inches Hg); a hydraulic, swiveling hose reel that carries 660 feet of 1 1/4-inch-diameter hose; and a second reel for smaller-diameter hoses.

Two features set the machine apart from conventional vacuum trucks. The first is the water-recycling system. Here’s a simplified explanation of how it works: The truck vacuums up water-filled sludge into the debris tank. The reclamation system sucks that water out of the debris, then sends it through a set of filters and cyclones that separate heavy solid particles. From there, the solids go into the sludge tank and water is pushed into the water tank, where it travels through another set of even finer filters. Then it’s ready to be used for waterjetting operations, Sorensen says.

“It takes about 15 minutes to clean enough water to start jetting,” Sorensen says.

## MORE MANUFACTURERS ROLL OUT RECYCLING TECHNOLOGY

The RECYcler from J. Hvidtved Larsen A/S has been proven in Europe, and now that it’s gaining a foothold in the U.S. as demand for water recycling technology grows, other manufacturers are following suit with their own systems.

Super Products, Vacall and Vactor are among the manufacturers who are addressing this emerging segment of the market with systems aimed at saving water, time and money.

The Camel 1200 jet/vac trucks with water-recycling packages use substantially less potable water to clean sewer lines. In fact, the unit will save an average of about 8,000 gallons of water a day while cleaning 1,000 feet of sewer (though that number could vary a bit, depending on the pipe’s diameter), says Mike Drott, Midwest regional sales manager for Super Products.

“That also means that stormwater treatment plants are treating 8,000 fewer gallons per day,” he notes.

Moreover, field tests show that the water-recycling Camels improve productivity by about 40 percent because they can operate

unit can actually work with an empty water tank. If there’s no water in the sewer line being cleaned, one full tank of water will provide enough to work all day without refilling, Drott explains.

Here’s a simplified explanation of how it works: In a primary settling chamber in the debris tank, a device called an ejector plate separates the liquids and solids. Then the water passes through the plate, which serves as the primary filtration point, and enters a sediment chamber. From there, the water is first pumped through a filtration screen and then through a centrifugal separator and a Y-strainer. Then it’s fed into the jetting water



pump, ready to be used for further cleaning.

“It’s pretty much a closed-loop system from the sewer to the debris tank, then through the water pump and back into the sewer,” Drott says.

At the end of a workday, the hydraulically operated ejector plate can be sent to the rear of the debris tank to compact the solids. Any remaining water is pumped out, leaving the truck with a dry load, Drott says.

The AllClean water-recycling option for Vacall AllJetVac combo units is designed to meet the same objectives.

The system uses a series of filters, screens and centrifugal

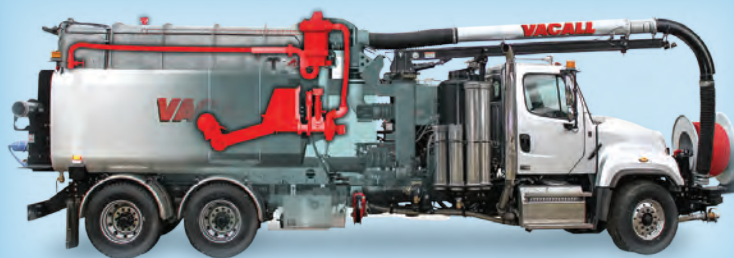

continuously, with no need to make time-consuming — and sometimes expensive — trips to refill the water tank. In fact, if there’s sufficient water flowing through the sewer line being cleaned, the



“But we have to be cleaning a sewer with running water in it. If it’s a dry sewer, we have to bring water along. But if it has decent flow, there’s no problem starting a job without any water in the tank.” When a cleaning operation concludes, any water still in the tank gets put back into the sewer system.

The truck offers another unique feature: a pneumatically operated partition that allows the operator to make the water tank bigger and the debris tank smaller, or vice versa, as needed. At the start of a cleaning operation, the partition is positioned as far back as possible to allow for more water and less debris capacity. But the partition gets moved forward as work progresses, so the debris section gets bigger and the water section gets smaller. When crews complete a typical line cleaning, two-thirds of the tank is devoted to debris and the remaining third to water, he explains.

Moreover, in a typical cleaning, 90 percent of the debris is so dry that

it’s ready to be hauled straight to a landfill, with no need for time-consuming decanting, Sorensen says. “Eliminating that step makes us more cost-effective,” he notes.

Water-recycling vac truck technology is just starting to gain traction in the United States. But manufacturers and operators are both climbing on board. “It’s in its infancy right now,” Lounsbury says. “There just aren’t enough units out in the field to drive the point home about the benefits to municipalities.

“We were skeptical at first,” he adds. “But we’ve been pretty impressed with Larsen’s responsiveness and the unit’s performance in the field. Eventually the word about the benefits will get out.” ♦

motions to remove matter from water collected in the debris tank before returning it to the water tanks.

A multistage recycling process starts with an initial sediment separation followed by a floating V-Filtration screening process further separating water from debris. The V-Filtration also has backflush, self-cleaning capability. Centrifugal action removes remaining solids, including particles down to 100 microns. Solids and fine particles are returned to the debris tank via a pressure-regulating valve system. Recouped jetted water — up to 65 percent from a sewer line — is returned to the water tanks for reuse.

“Productivity is going to increase tremendously,” says Bill Petrole, vice president of sales and marketing for Vacall. “If you have a large job with a lot of jetting to do, it doesn’t take long to empty your water tanks. The benefit would be the length of time you can stay on the job or stay away from the dump.”

The system is located at the front of the AllJetVac debris body, protected from damage by stones or other vehicles. Petrole says this also allows them to offer an inexpensive alternative to a dedicated truck.

“We can take a normal sewer truck that we’re producing and, as an option, add the recycler onto it so the municipality has a dual-purpose machine,” he says. “They can fill up the water tanks in the morning and go out and use it like a conventional combo truck, or they can go out in the morning and recycle water and use it as a recycler.”

“The recycling concept has been in Europe for a long time, and the system that we’re using has been around for a long time,” Petrole says. “It’s a proven way of doing things.”

Vector developed its first water-recycling system in the 1980s, but its most recent version is much more user-friendly, says Dave Brockman, a product manager at Vector.

“It was a bit ahead of its time, but that system required getting into the debris body to maintain it, and what we found is you’re going to do that one time and you’re never going to want to do it again,” he says. “That’s why we went back to the drawing board and developed the system we have now.”

That’s one of the top features of Vector’s newest water-recycling system — no moving parts inside the debris body. Everything is located on the exterior of the machine, making it easier and safer for operators to maintain.

“One of our main design criteria was to make sure nobody ever had to get inside that debris tank to maintain the system,” Brockman says.

The system, an option for Vector’s 2100 Plus Series, uses a five-stage filtration process: natural settling in the debris body followed by a coarse-screen filter, centrifugal separation, a classification filter rated at 100 microns, and final settling in a stainless steel reservoir.

“Productivity can increase up to 100 percent while saving thousands of gallons of freshwater every shift,” Brockman says.

Vector did a demo recently for one contractor, who was able to save 21,660 gallons of freshwater during a single day of work.

“Taking care of the environment and ensuring clean water resources is at the core of what Vector and the 2100 Plus Series are all about, so adding water-recycling technology was a natural step in our long history of product innovation,” Brockman says.





# lateral inspection takes a **new** direction

The patent-pending CleanSteer combines powerful propulsion, positive steering and bidirectional jetting to view and clean drains and laterals from any main line or clean-out.

Propelled by high-pressure water (1), CleanSteer snakes past multiple bends. A side jet is aimed remotely to steer through branches (2) and levitate over debris (3), and a forward jet can be pulsed to clear obstructions (4).

CleanSteer is ideal for locating cross-bores (5), pipe failures and blockages, all while jetting lines clean.



**FREE On-site Demo**  
Register at [www.pipelinert.com](http://www.pipelinert.com)



(973) 252-6700

an **Envirosight** company.

Patents pending.  
©2016 Pipeline Renewal Technologies. All rights reserved.  
CleanSteer is a trademark of Pipeline Renewal Technologies.

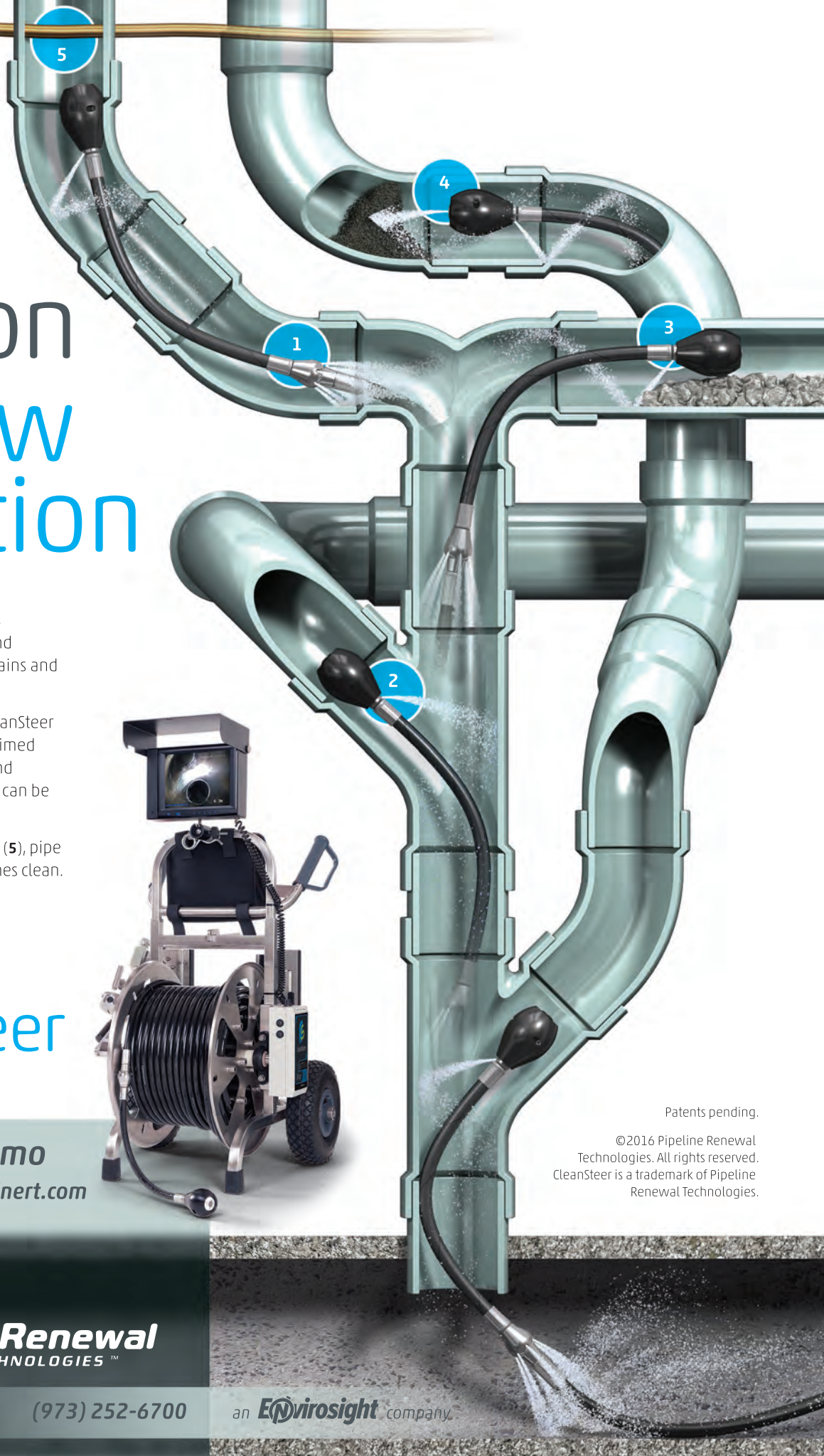



# INSIDE DROP SYSTEM

by RELINER® / Duran Inc.

U.S. Patent 6074130 Canadian Patent 2269565

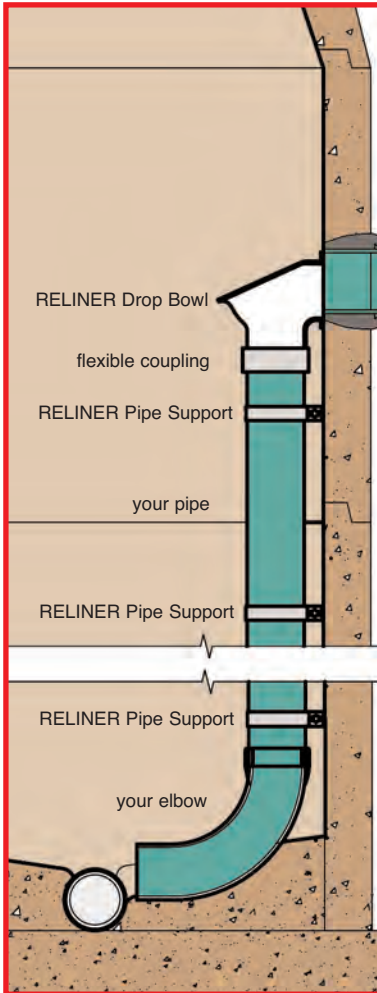

Drop Bowl

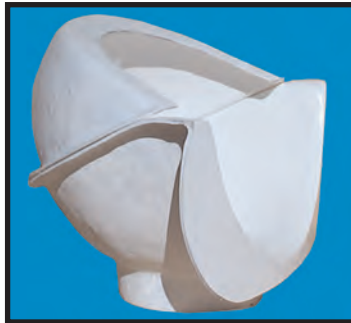

Drop Bowl with Hood



Stainless Pipe Support

## Drop Bowl & Pipe Supports

- Eliminate troublesome outside drops
  - Reduce maintenance
  - Simplify inspection
  - Clean from above
  - Install quickly
  - Simply bolts to manhole wall
  - Stop corrosion
  - Ideal for wet wells - Increase pump life
- Made in the U.S.A.**

[www.reliner.com](http://www.reliner.com)  
800-508-6001



## Pressure Washers and Drain Jetting Equipment



Skid and truck mount models up to 7000 psi



Portable Hot and Cold Water Diesel Powered Models



Hot and Cold Trailer Models  
Up to 7000 psi  
Flows up to 40 gpm  
Powered Reels  
Diesel powered models

We will custom build to your specifications  
[www.camspray.com](http://www.camspray.com) 800-648-5011



## Ultimate Corrosion PROTECTION

Sauereisen's vast selection of polymer linings offer superior corrosion protection, chemical resistance and abrasion resistance for municipal and industrial treatment plants including the collection systems, concrete and steel tankage and secondary containment.

**Extend the life of your structure by contacting us for an Engineered Solution.**

# SAUEREISEN

160 Gamma Drive  
Pittsburgh, PA 15238-2989, U.S.A.  
P (412) 963-0303 • F (412) 963-7620  
[www.sauereisen.com](http://www.sauereisen.com)





# ROOTS DON'T STAND A CHANCE.



Wherever you need quick, safe and effective root control, RootX® has you covered. Because the same proven RootX® formulation trusted by scores of municipal sewer departments is also available for plumbing professionals in easy-to-use "shake and pour" jars. So whether you're treating miles of city pipe, or just a residential line, RootX® is the right solution, right now.



weftec 2016  
Booth 1412



To purchase RootX®, or to learn more, visit [www.RootX.com](http://www.RootX.com), or talk to your RootX® representative at 1-800-844-4974.

**THE RIGHT SOLUTION.  
RIGHT NOW.**



# FIGHTING FOR INFRASTRUCTURE FUNDING

Local leaders pull together to secure state funding for badly needed infrastructure upgrades in Tallulah, Louisiana

By *Ted J. Rulseh*



Tallulah chief water and wastewater operator Carlton Whitaker checks the water in Tallulah. Water is tested for pH and chlorine levels three times a day. (Photography by Eli Baylis)



**T**he Louisiana city of Tallulah prospered for many years, until the 1970s, when a large lumber mill closed down and the newly built Interstate 20 diverted east-west traffic around the community.

As the local economy declined and the tax base dried up, critical infrastructure — water, wastewater and streets — fell into neglect. Failing lift stations led to flooding and sewer backups during rain events. The wastewater treatment facility frequently exceeded effluent permit limits. The drinking water treatment plant slowly deteriorated, requiring frequent repairs, and a breakdown in early 2014 left the community without water for 26 hours.

Today, Tallulah's water infrastructure is well positioned for the future. An upgraded wastewater treatment facility went online early this year, and plans and funding are in place for a new drinking water system to be commissioned in 2019.

It's all paid for, to the tune of nearly \$23.5 million, through the state's Capital Outlay Fund for infrastructure, and without the customary 25 percent local match. "The matching funds were a major issue," says Mayor Paxton Branch. "As a small rural community with a low tax base, we couldn't afford it." A persistent lobbying initiative involving the mayor's office, operations personnel, city council members and citizens persuaded the state Legislature to waive the local match requirement.

### Big relief

Branch made water infrastructure improvements the cornerstone of his 2015 campaign for mayor. From the time he assumed the office, it took 14 months to arrange the funding — \$1.5 million for wastewater improvements and \$22 million for the new water system.

"The \$1.5 million grant for the wastewater plant improvements was awarded under the previous administration," Branch says. "However, it had been sitting idle for years. Once I knew that it was there, I took a look at the engineers' plans. They assured me the plans would work, and we recommitted the money toward the wastewater plant upgrades."



**Carlton Whitaker uses a Hach colorimeter to sample water in Tallulah.**





**PROFILE:**  
**Tallulah (Louisiana)**  
**Utilities Department**

**POPULATION SERVED:**  
 13,100

**EMPLOYEES:**  
 12

**ANNUAL BUDGET:**  
 \$1.7 million (water and wastewater operations)

**WEBSITE:**  
[www.cityoftallulah.org](http://www.cityoftallulah.org)

For Carlton Whitaker, chief water and wastewater operator, it was a major relief. “I’ve been through a lot of mayors as an operator for Tallulah in different capacities,” he says. “I’d been preaching for years that we had to do something and do it quick. Mayor Branch took the bull by



**Charles Fines inspects a Master Meter water meter.**

**Tallulah Water Service employees Charles Fines (left) and Robert Neal mark waterlines for new construction.**

the horns and went out there and made this thing happen. He got on the end of the rope with me and we all pulled together.”

First in line was \$400,000 in improvements for the lift stations. Four of the city’s eight stations received a total of four new 50 hp Gorman-Rupp pumps. The main lift station, which delivers influent to the treatment headworks, received an 8-inch, 75 hp Gorman-Rupp submersible sewage pump rated at 3,600 gpm, as well as a new 50 kW diesel emergency generator to keep the pumps operating through power outages.

Next up was a \$1.25 million wastewater treatment upgrade. The existing facility included a

facultative pond for primary treatment, followed by overland flow across 260 terraced acres. However, that system experienced effluent problems and wasn’t meeting permits.

The new 2.5 mgd design replaces the overland flow phase with aeration in the existing pond, followed by a secondary clarifier.

**The water side**

Plans for water system improvements include new drinking water wells, a new transmission pipeline and a new water service facility.

The project, fully state-funded, will replace an antiquated treatment plant and provide much higher-quality source water that will require a far less complex and chemical-intensive treatment process, according to Whitaker.

The Upper Mississippi Alluvial Aquifer from which the city now draws source water is naturally high in arsenic and barium (both above U.S. EPA maximum concentration limits) and in iron and manganese, says Whitaker. The new plan is to tap the Cockfield Aquifer, about 30 miles from the city.

“We expect to draw more pristine water that doesn’t have the constituents our source water has now,” Whitaker says. “We have high hopes of getting water that will require only disinfection and possibly light filtering. We also hope to sell water to other smaller communities along the route of the trunk line to Tallulah.”

The new water service facility will replace a 66-year-old plant that uses enhanced

lime treatment followed by mixed-media filtration. That plant is showing impacts of aging that include metal corrosion, metal fatigue and leakage. Replacement parts are hard to find. In addition, lime floc carryover from the settling process leads to frequent blinding of the filters and excessive backwashing.

The new facility will double current capacity to 3 mgd and is expected to meet the city’s needs for 20 years. The water system project is to be completed in three years.

**Community commitment**

Securing funding for the improvements wasn’t easy. The state budget was deep in deficit, and the Legislature tended to focus on major problems facing much larger cities, Branch says. In addition, matching fund waivers were rare.

*(continued)*



# Strong-Seal®

## SYSTEMS

*The Technology Leader in Manhole Rehabilitation*



## Strong-Seal® Systems

*The fast, cost-effective solution for*

- Stopping infiltration
- Restoring structural integrity
- Corrosion protection

Offering  
Manhole  
Rehabilitation  
Solutions Since  
**1989**

## Complete Family of Strong-Seal® Engineered Products

- MS-2A - Portland cement based structural lining material
- MS-2C - Calcium Aluminate based structural lining material
- High Performance Mix - 100% pure fused Calcium Aluminate cement and aggregate structural lining material
- Profile Plus - Calcium Aluminate underlayment for epoxy/urethane coating
- Strong Plug
- Quick Set Repair (QSR)
- Bench Mix
- Strong-Seal® Ring Sealant
- Dependable and high output application equipment

THE  
**Strong Company**  
I N C .

Toll-free: **(800) 982-8009**

Fax: (870) 850-6933

E-mail: [info@strongseal.com](mailto:info@strongseal.com)

Web Site: **[www.strongseal.com](http://www.strongseal.com)**





Sewer Department employee Johnny Robertson inspects the main lift station in Tallulah.

Whitaker and Branch, both with strong local ties, approached the challenge with conviction. Branch, a native of Madison Parish (of which Tallulah is the seat of government) had been parish president for eight years while working as a district manager with Holiday Inn Worldwide. “I understood how government works, and as a businessman I also understood cash flow and the importance of planning, setting timelines and sticking to them,” he says.

Branch came into the mayor’s office while the city faced administrative orders from the Louisiana Department of Environmental Quality to improve the wastewater treatment process. “The system wasn’t going to get any better,” he says. “It was only going to get worse. That became my priority, because water is the common denominator for this entire community.”

Whitaker, a Tallulah native, has been with the city as an employee or contract operator for the past 31 years, except for three years working with a U.S. government contractor during the Iraq War, coming home in 2010. He holds Class IV (highest) licenses in water production, treatment and distribution and in wastewater treatment. He is also a member of American Water Works Association

and the National and Louisiana Rural Water associations.

### All-out effort

Lobbying for the fund-matching waiver meant extensive preparation, followed by heavy activity during a 45-day legislative cycle. The initiative reached directly to the grass roots. City officials held community meetings, engaged the news media and circulated petitions supporting the waiver. Residents and officials wrote letters to legislators describing their experiences with water and wastewater system failures.

“Everything was about the timeline,” says Branch. “Our city council was very supportive. They were not hesitant. They helped us in getting the community involved, securing the letters of support that we needed. All members did what they needed to do within their districts.”

One key step was a meeting with the LDEQ. Says Whitaker, “We took an entourage including myself, the mayor and our engineering consultants. We explained all the problems we’d been having and showed them our plan of action.”



Johnny Robertson checks the control panel at the main lift station.

The result was that the LDEQ gave the city a letter of endorsement to be used with legislators. Branch recalls, “That and the many other letters of support we received really got us over the top. We had written documentation that we were facing a health issue.”

City officials lobbied legislators throughout the floor session. “We were there every other day, making sure our voices were heard,” Branch says. “That was the biggest thing — just being there and letting them know how serious our problems were.” The local legislative delegation of Sen. Francis Thompson and Reps. Andy Anderson and Charles “Bubba” Chaney strongly advocated for the city.

“Evidently it worked, because when it came time for the vote, the measure passed unanimously and the waiver was given,” Branch says. “Many



people were amazed that a town our size was able to procure such a magnitude of funding. It was hard work. We understood process and followed it all the way through to the very end.”

**Tallahassee Water Service employees Robert Neal (left) and Charles Fines service a residential water meter.**



## PROMOTING EXCELLENCE

Improvements to Tallahassee’s water and wastewater systems don’t stop with new infrastructure.

Mayor Paxton Branch has launched an operator training initiative to help the city’s personnel advance their skills and advance to high-level licenses.

The city arranges for operators to attend training courses offered by the American Water Works Association and the Louisiana Rural Water Association. “We need trained people on the job, and it’s hard sometimes to get operators to take advantage of the training that’s available,” says Carlton Whitaker, chief water and wastewater operator. “The mayor has been making use of resources that we had never used before.”

The wastewater operations team — in addition to Whitaker — includes Ed Kline, treatment plant operator; Eddie Blanson, sewage operator; and Johnny Robertson and Kelvin Brooks, sewage technicians.

The water plant team consists of Michael Goods, David Moore and Tommy Jobe, operators; and Charles Fines, Edward Jones, Elvis Meadows and Robert Neal, water technicians.

## Lessons for others

Whitaker and Branch agree that their experience can serve as an example to other communities struggling to fund large and essential water infrastructure projects.

“What I would tell anyone is that you have to be able to analyze and prioritize,” says Branch. “That is the key. Once you get your plan, stick to it, no matter what. If you don’t, you’ll find yourself wavering. Take the time out to plan and research and know what you need to do.”

As an elected official, he saw the importance

of acting early in his four-year term: “You may not be fortunate enough to win another term. Then someone comes in and has brand-new ideas, and your hard work just goes out the window.”

Whitaker, meanwhile, learned persistence: “My perspective is never to give up on a plan, even if it looks 20 years into the future. If you have a plan, stick to it. Be consistent. Be consistent with the press. Be consistent in everything you do in the water business. If you do, eventually you will reap the benefits.” ♦

# PIPE BURSTING PROS DEPEND ON HAMMERHEAD

“No-DigTec specializes in pipe bursting, both water and sewer, and we rely on HammerHead equipment on all our jobs. When I need HammerHead equipment I haven’t bought yet, I rent it. Their tools are far easier to work with than others we’ve tried. Working with them, we’ve successfully completed some of the toughest pipe bursting projects in the country, on time and on budget.”

**JOHN L. NEWELL,**  
President  
No-DigTec, Dallas, Texas USA

## EQUIPMENT. EXPERTISE. SUPPORT.

HammerHead equipment and expertise take the guesswork out of pipe bursting. And legendary HammerHead support puts even the toughest pipe bursting jobs within your reach.



Find your local dealer at  
[hammerheadtrenchless.com](http://hammerheadtrenchless.com)  
or call 800-331-6653



MOLING | RAMMING | BURSTING | HDD ASSIST | WINCHES | CIPP

©2016 Earth Tool Company, LLC

A Charles Machine Works Company

## FEATURED PRODUCTS FROM:

**Gorman-Rupp Company**  
419/755-1011  
[www.grpumps.com](http://www.grpumps.com)

**Master Meter, Inc.**  
800/765-6518  
[www.mastermeter.com](http://www.mastermeter.com)

**Hach**  
800/227-4224  
[www.hach.com](http://www.hach.com)



*Jack and Jill  
Need water still  
But buckets get  
too rusty  
And now they see  
That FRP  
Is something much  
more trusty.*



weftec 2016  
Booth 1545

*Engineers all across North America and around the world are specifying affordable, low-maintenance Flowtite® FRP pipe. Learn more about its remarkable hydraulic efficiency in the October session of our popular webinar series.*

Visit [www.flowtite.com](http://www.flowtite.com) or call (225) 658-6166 today.



**POWERHOUSE MUNICIPAL SOLUTIONS**



[www.CHEMPACE.com](http://www.CHEMPACE.com)

**CONTINUOUS TREATMENT!**

**bioFORCE BRICK**  
Bacterial treatment, controls odors & reduces grease

**bioFORCE HEAVY DUTY GREASE PACKET**  
Biological grease control

**ORANGE AID**  
Floating degreaser & deodorizer dissolves grease and sludge  
CITRUS AROMA

**SEWER FOAM**  
Dual-action, foaming cleaner with long-lasting bacterial treatment. Eliminates sewer line solids & hydrogen sulfide odors!

**BEFORE AFTER**  
CALL FOR FREE DVD!

**800-423-5350**  
BUYING DIRECT ALWAYS EQUALS COST SAVINGS!

**INFRASTRUCTURE REPAIR SYSTEMS, INC.**

**PRECISION.  
EASE. VALUE.**



**Precise Liners**

**Best Value**

**Easy Installation**

**TAKE THE HASSLE OUT  
OF YOUR POINT REPAIRS  
CALL 1.877.327.4216**





# SOUTHLAND TOOL MFG. INC.

*Building Innovative Tools for Municipalities*



## SOLUTIONS TO SEWER CLEANING THROUGH:

- **CONCEPT**
- **DESIGN**
- **PRODUCTION**

Manhole Tools • Debris Baskets • Vac-Traps • Root Saws  
Calcium Cutters • Sewer Rods • Handy Clams  
Nozzle Extensions • Deep Vac Tube Holder  
Grabbers Claws and Hooks • Diamond Tap Cutters  
Fiberglass Poles • Hydraulic Cutters • Top Manhole Rollers  
Sewer Spoons • Continuous Rod • Carbide Saws



1430 N. Hundley St  
Anaheim, CA 92806

ph: 714.632.8198  
fax: 714.632.8228

[www.SouthlandTool.com](http://www.SouthlandTool.com)





# BACK TO SCHOOL

Education never ends for those pushing the trenchless industry forward

By *Ted DeBoda*

It's hard to believe the summer is behind us and our children are already heading back to school. But school isn't just for kids. This is also a great time for you to refresh your industry knowledge and keep up to date on the latest in trenchless technologies.

In addition to the resources, webcasts and FAQs available at [nassco.org](http://nassco.org), COLE Publishing has begun a regular series of online Pipeline Assessment Certification Program quizzes that can be found at [cleaner.com](http://cleaner.com). Designed to test your knowledge, the quizzes cover the proper assessment and coding of defects, including structural, operation and maintenance, construction, and other miscellaneous features, giving you regular refreshers on best practices in PACP standards.

Fall is also the time to gear up for industry conferences, which offer many opportunities for education and advancement of knowledge. For example, NASSCO's Annual Conference, scheduled for Feb. 13-16, in Naples, Florida, includes an intensive Technical Day to cover the latest trends and advances in trenchless technologies. The tentative 2017 schedule will include two separate tracks.

## Track A – Inspection, Asset Management and Training

- Lateral Inspections: Push Cameras vs. Lateral Launch (Kyle Dehne, Jack Doheny Companies)
- Phased Assessment Strategy for Sewers (PASS): Understanding Sewer Conditions Quicker with Fewer Resources (Steve Sebastian, EnviroSight)
- Acoustic Inspection Implementation at New Castle County, Delaware (George Selembo, InfoSense)
- Small Utility Asset Management (Jim Harris, Jacobs Engineering)

- Importance of Training, Why Train/Why Now (Jack Weimer, Jack Doheny Companies)

- Others to be announced

## Track B – Rehabilitation

- Design Considerations and Benefits of Pipe Bursting (George Malla-kis, IPBA & TT Technologies Inc.)
- Holistic Trenchless Sewer Rehabilitation Project in Utah (Jeff Maier, C&L Water Solutions Inc.)
- Sealing from the Ends: The Internal Pipe End Seal (Lee Haessig and Peter Blais, P.d., Cretex Specialty Products)
- Critical Details for Municipal Grouting Long-Term Success (Don Rigby, Avanti International; John Nelson, Visu-Sewer Inc.; Marc Ancil, Logiball Inc.)
- Others to be announced

Soon after NASSCO's Annual Conference we will be heading to Indiana for WWETT 2017. Lynn Osborn, NASSCO's technical director, will moderate NASSCO Education Day on Wednesday, Feb. 22, with topics that cover UV-cured lining, pipe bursting, an overview of lateral and main/lateral connection investigations and rehabilitation technologies, as well as a discussion on maximizing ROI with grout, acoustic inspections, and combating I&I with better infrastructure intelligence.

Education is important to NASSCO because it is a driving force behind our mission to set standards for the assessment, maintenance and rehabilitation of underground infrastructure and to ensure the continued acceptance and growth of trenchless technologies. We invite you to learn more at [nassco.org](http://nassco.org). ♦

## Get the EDGE Training and Continuing Education Courses

### PACP TRAINING

#### September 12-14

##### Marriottsville, MD

Includes Manholes and Laterals!

Trainer: Ted DeBoda

Contact Dawn Jaworski for more information or to register: 410/442-7473 or email [dawn@nassco.org](mailto:dawn@nassco.org)

#### September 12-14

##### Eatontown, NJ

NJWEA Tech Transfer

Includes Manholes and Laterals!

Recertifications Welcome

Trainer: Jerry Weimer

Contact Ashley Groves for more information or to register: 248/349-0904 or email [pacp@dohenycompanies.com](mailto:pacp@dohenycompanies.com)

#### September 12-14

##### Hawthorne, CA (Los Angeles)

Includes Manholes and Laterals!

A limited number of PACP Recertification seats available.

Contact Marilyn Shepard for more information or to register: 916/899-8961 or email [mshepard1@hotmail.com](mailto:mshepard1@hotmail.com)

#### September 13-15

##### Conyers, GA

Includes Manhole and Laterals!

Recertifications Welcome

Contact John Jones for more information or to register: 404/431-5584 or email [plumblineconsultant@gmail.com](mailto:plumblineconsultant@gmail.com)

#### September 20-22

##### Northville, MI

Includes Manholes and Laterals!

Recertifications Welcome

Trainer: Brandon Conley

Contact Ashley Groves for more information or to register: 248/349-0904 or email [pacp@dohenycompanies.com](mailto:pacp@dohenycompanies.com)

#### September 19

##### Las Vegas, NV

In Conjunction with Tri-States Conference

One-Day Recertification Course

Contact Marilyn Shepard for more information or to register: 916/899-8961 or email [mshepard1@hotmail.com](mailto:mshepard1@hotmail.com)

#### September 20-22

##### Las Vegas, NV

In Conjunction with Tri-States Conference

Includes Manholes and Laterals!

A limited number of PACP Recertification seats available.

Contact Marilyn Shepard for more information or to register: 916/899-8961 or email [mshepard1@hotmail.com](mailto:mshepard1@hotmail.com)

#### September 21-23

##### Seattle, WA

Includes Manholes and Laterals! (if desired)

PACP Recertification seats available

Contact John Jurgens for more information, register or discuss in-house training: 425/487-3325 or email [nodig@aol.com](mailto:nodig@aol.com)

#### September 23

##### Northville, MI

One-Day Recertification Course

Trainer: Brandon Conley

Contact Ashley Groves for more information or to register: 248/349-0904 or email [pacp@dohenycompanies.com](mailto:pacp@dohenycompanies.com)

## ITCP TRAINING (CIPP and Manhole)

#### September 21-22

##### Marriottsville, MD (NASSCO Training Center)

Cured In Place Pipe

8 a.m. – 5 p.m. Day 1 • 8 a.m. – 1 p.m. Day 2

Trainer: Gerry Muenchmeyer

Contact Gerry Muenchmeyer for more information:

252/626-9930 or email [gerry@muenchmeyerassoc.com](mailto:gerry@muenchmeyerassoc.com)

## OTHER CLASSES FORMING

Contact one of the trainers listed above if you are interested in having a class at your facility or in your area.

NASSCO  
PRO  
TRAINING







 **FERGUSON**  
*Waterworks*

*Meter & Automation Group*

## Leading Meter Brands from the Industry Leader.

Ferguson Waterworks is the industry leader when it comes to supplying the top water meter brands. These brands are supported through significant meter inventory, knowledgeable associates and expert installation capabilities.

Let Ferguson Waterworks help you design the right meter from the top brands in the business.

 **FERGUSON**<sup>®</sup>  
*Waterworks*

*Meter & Automation Group*

Find the closest waterworks location near you at

**[FERGUSON.COM/WATERWORKS](http://FERGUSON.COM/WATERWORKS)**



## NEW TECHNOLOGY SLATED FOR WEFTEC 2016

By Craig Mandli

WEFTEC, the Water Environment Federation's annual technical exhibition and conference, offers water and wastewater professionals from around the world exposure to the newest products, along with water-quality education and training. This year's event, slated for Sept. 24 to 28 in New Orleans, Louisiana, promises to show off some of the finest new products on the market for municipal and industrial water and wastewater professionals. Below is a smattering of some of the newest products that will be highlighted at this year's show.

### Aerzen Biogas Blower

**Aerzen Biogas Blowers** are designed for digester gas applications, ensuring process safety and reliability. Operators can choose from a variety of sizes with intake volume flows of 50 to 1,500 inlet cfm and positive pressure up to 15 psig. **610/380-0244; www.aerzenusa.com; Booth 7339.**



### AllMax Software



**AllMax Software** combines software and service offerings to provide operations and maintenance solutions that make data management and reporting tasks easier and less time-consuming. Operator10 and Antero have been developed according to client requests and the requirements of the industry. Software setup, data conversions and training are available, as well as custom report development. Annual technical support contracts offer users the ability to get help with troubleshooting and usage questions. Technical specialists are trained in water and wastewater concepts. **800/670-1867; www.allmaxsoftware.com; Booth 3110.**

### Analytical Technology Q46N Free Ammonia Monitor

The **Q46N Free Ammonia Monitor** from **Analytical Technology** is designed for the continuous measurement of free ammonia, total ammonia and monochloramine in potable water. It is intended for monitoring chloraminated water to minimize the amount of excess ammonia in the system. Three separate reagents are required for operation, and can be purchased directly from the company or be easily mixed on site using readily available chemicals. The unit includes replacement parts for routine maintenance, a monitor, chemistry module, sensor membranes and electrolytes, reagent bottle brackets, reagent pickup tubing assemblies, a spare parts kit, and a copy of the manual. **800/959-0299; www.analyticaltechnology.com; Booth 7239.**



### Anua Airashell



**Airashell** from **Anua** is a modular biofilter with a small footprint. The air treatment system removes a wide variety of noxious odor compounds, including over 99 percent hydrogen sulfide, and can handle high variability in compound concentrations. It is prepackaged with recycled seashells, which protects the environment while reducing solid waste. The seashell media acts as a host for biological activity and a catalyst for pH neutralization. Chemicals are not required, operation is easy and life cycle costs are low. Applications include manholes, lift stations, wastewater treatment plants, biosolids processing facilities, manufacturing facilities and solid waste or composting operations. **336/547-9338; www.anuainternational.com; Booth 152.**

### Applied Felts AquaCure

**AquaCure RP** from **Applied Felts** combines fiberglass reinforcement with the company's felt liner design. AquaCure PS is specially designed for pressure sewer pipes and other non-potable water applications, and AquaCure PW is suited for potable water applications, designed to incorporate quality liners with an NSF-certified system. **276/656-1904; www.appliedfelts.com; Booth 2204.**



### Aqua-Aerobic Systems AquaPrime



The **AquaPrime** cloth media filtration system from **Aqua-Aerobic Systems** is an economical and efficient solution for primary wastewater treatment and wet weather applications. It uses a disc configuration and OptiFiber cloth media to filter screened, de-gritted, raw municipal biosolids. The system can handle high solids applications and sustain low effluent TSS, making it ideal for both wet weather treatment and primary treatment in lieu of conventional sedimentation systems. It operates in less than 10 percent of a footprint compared to conventional primary settling basins and offers the added advantage of improving gas production in the anaerobic digestion system. **800/940-5008; www.aqua-aerobic.com; Booth 829.**

### BJM Pumps SKG Series/RAD-AX

**SKG Series/RAD-AX** submersible pumps for flushable wipes from **BJM Pumps** include both radial and axial shredding elements, high torque, and a four-pole motor available in 2, 3 and 5 hp models. All shredding elements are constructed of hardened 440C stainless steel with a Rockwell hardness of 55C plus. The shredding system efficiently alleviates potentially high surge load to the motor. It has an efficient, high solids passage impeller and volute design, with oil-lubricated double mechanical seals and a separate lip seal. It comes with heavy-duty SOOW power and Seal Minder cable for early warning moisture detection. **860/399-5937; www.bjmpumps.com; Booth 2251.**



### Blue-White Industries Sonic-Pro Ultrasonic Flowmeter



**Sonic-Pro Ultrasonic Flowmeters** from **Blue-White Industries** measure fluid flow in virtually any fluid in which sound waves can travel. This hybrid ultrasonic flowmeter can be used in either Doppler or Transit Time operation modes, and because the meter doesn't come in contact with fluid being measured, it can be used in applications where harsh chemicals and abrasive fluids are being measured. Its T-Track Mounting System is designed to facilitate quick and accurate mounting of transducers, using a built-in ruler



and mounting base to ensure transducers are perfectly aligned and spaced. A Windows PC can be used to view real-time flow and download data log files remotely. **714/893-8529; www.blue-white.com; Booth 2441.**

### Bright Technologies belt filter press unit



The 1.7-meter, trailer-mounted belt filter press unit from **Bright Technologies** has an insulated control room with FRP walls, air conditioning, electric heat, a refrigerator, stainless steel desk, tool storage, locker, closed-circuit TV and remote operator controls. The modular design allows the room to be custom manufactured to fit most single-drop trailers. Units are made for rapid setup, with folding conveyor and operator walkways. No special lifting equipment is required. **800/253-0532; www.brightbeltpress.com; Booth 6347.**

### Centrisys THK Thickening Centrifuge

The **THK Thickening Centrifuge** from **Centrisys** decreases polymer consumption while increasing capacity with little to no polymer required. Treatment plants can expect a return on investment in 2 1/2 years with polymer savings alone. The hydraulic-assist technology allows for instantaneous cake solids control. The thickener has a small footprint and is airtight, resulting in less odor. It maximizes uptime while decreasing operator attention, creating additional savings for treatment plants. **877/339-5496; www.centrisys.com; Booth 4209.**



### Cretex LSS Internal Manhole Chimney Seal



**Cretex LSS Internal Manhole Chimney Seal** is a mechanical seal installed on the frame and grade ring sections of sanitary sewer manholes. These seals eliminate and prevent manhole frame-chimney inflow. During wet weather, clear water enters manholes through deteriorated and broken frame-chimney joints, which may burden the collections system. Each seal is made up of a high-grade rubber sleeve and stainless steel expansion bands, which can be easily removed and reinstalled to allow for future manhole adjustments. It has a 50-year design life and is available in four widths, allowing complete chimney coverage of up to 24 vertical inches with a single seal. **800/345-3764; www.cretexseals.com; Booth 1319.**

### CUES Steerable Pipe Ranger II

The **CUES Steerable Pipe Ranger II** is a versatile robotic camera transporter designed to traverse silt, mud and debris commonly found in storm and sanitary sewers. It is designed with single-point wheel removal to facilitate speedy configuration changes for various pipe diameters and conditions. Optional high-traction tires are available for slippery conditions. The unit is designed to operate with all CUES inspection systems with up to 2,000 feet of single- or multi-conductor cable to inspect 7- through 72-inch-diameter pipe. **800/327-7791; www.cuesinc.com; Booth 1111.**

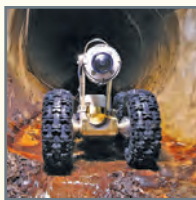

### Duke's Root Control



**Duke's Root Control** provides chemical root control applied by professional crews, with ongoing customer support to help manage budgets and navigate complex consent decrees to eliminate sanitary sewer overflows. Razorooter II diquat-based herbicide is registered by the EPA for controlling

nuisance tree roots in sanitary sewer line collections systems, and received a classification of "evidence of noncarcinogenicity for humans" (U.S. EPA R.E.D. fact sheet for diquat bromide, July 1995). Applications prevent root-related stoppages for two to three years. **800/447-6687; www.dukes.com; Booth 4011.**



### Flygt - a Xylem Brand Concertor

The **Concertor**, a new wastewater pumping technology from **Flygt - a Xylem Brand**, combines what the company knows about tough wastewater challenges with a fully integrated design. Visit Xylem on Sept. 26, at 10 a.m., for the unveiling. **855/995-4261; www.flygtus.com; Booth 2529.**

### Force Flow/Halogen Chlor-Scale and Eclipse

The **Chlor-Scale** ton container scale from **Force Flow** safely cradles a chlorine ton container while providing critical feed and chemical inventory information. It can be combined with the **Halogen Eclipse** emergency valve shut-off system to instantly close the container valve when a signal is received from a leak detector, panic button or from SCADA. **925/893-6723; www.forceflow.com; www.halogenvalve.com; Booths 2216 (Halogen) and 2218 (Force Flow).**



### Fournier Industries Rotary Press



The **Fournier Industries Rotary Press** uses screens and pressure to efficiently dewater all types of municipal and industrial sludge. Its heavy-duty construction with few components reduces maintenance, and the advanced control system allows for unattended operation. The totally enclosed design mitigates odors and provides a healthy work environment. The unit can be equipped with a single dewatering channel or up to six channels on a single machine. It has low power usage, low noise levels, very little water use and a compact footprint. **952/288-5771; www.rotary-press.com; Booth 3708.**

### Franklin Miller Taskmaster TM8500

**Taskmaster TM8500** grinders from **Franklin Miller** employ cutter cartridge technology that reduces maintenance and increases unit strength by taking six individual cutters and spacers and combining them into one rugged cartridge. They can be used in wastewater treatment plant headworks, sludge lines, pump stations, and in prison sewer systems. They provide optimal protection of plant processes and equipment, as well as trouble-free operation. These versatile processors finely reduce such materials as rags, plastics, wood, debris, tampons, sanitary napkins and solid waste to keep pipelines flowing, reduce pump downtime, enhance screenings handling and protect dewatering equipment such as centrifuges and filter presses. **800/932-0599; www.franklinmiller.com; Booth 1329.**



### Grundfos Dosing Skid System (DSS)



The **Grundfos Dosing Skid System (DSS)** is a pre-engineered floor or panel dosing system package that offers integrated controls and one-, two- or three-pump configurations designed to accurately meter liquid chemicals for a variety of water supply/treatment systems, as well as industrial and manufacturing applications. It uses an intelligent drive and microprocessor

(continued)



controller to ensure that each dose is performed precisely and with low pulsation, even with chemicals of high-viscosity or off-gassing properties. Packaged skid systems are available for all models of hydraulically and mechanically actuated metering pumps including SMART Digital dosing pumps with stepper motor technology offering up to 3,000-to-1 flow turndown. **913/227-3400; www.grundfos.us; Booth 4117.**

## Hach Company RTC-SD

The **Real-Time Control system for Sludge Dewatering (RTC-SD)** from Hach Company allows plants to achieve optimized polymer dosages by analyzing flow and feed sludge concentration in real time. This results in lower polymer usage, greater solids capture, and less maintenance within the plant. It can help improve solids capture and throughput, leading to increased throughput and reduced secondary wasting rates. **800/227-4224; www.hach.com; Booth 3814.**



## Hayward Flow Control HLS Series Level Sensor

The **HLS Series Level Sensor** from Hayward Flow Control is an accurate level sensor that is not affected by foaming, waves or headspace vapors. With a complete CPVC housing and construction, it is ideal for corrosive fluids and environments where metals cannot perform. It measures hydrostatic pressure and converts the reading to an analog 4-20mA signal, which can be displayed on a wide range of indicating transmitters or taken directly into a PLC. Its large ceramic diaphragm ensures accuracy and repeatability, while a triple-sealed cable entry into body and PFA-coated cable offers superior chemical compatibility. It has a 0 to 15 feet and 0 to 33 feet water measurement range, with 30- and 49-foot cable lengths standard, and other lengths available upon request. **888/429-4635; www.haywardflowcontrol.com; Booth 5349.**



## Huber Technology RoFAS Septage Receiving Station

The **RoFAS Septage Receiving Station** from Huber Technology is designed to handle harsh environments that may cause standard receiving stations to fail. It easily handles large rocks and debris, protecting headworks from unpredictable septage. Its large-capacity center-feed drum allows for rapid off-loading of tanker trucks. It provides the option for a fully automatic hauler station with card key access, quick connect and data logging. It can help create revenue opportunity for a quick return on investment. **704/949-1010; www.huberforum.net; Booth 4029.**



## Hydro International Hydro MicroScreen

The **Hydro MicroScreen** from Hydro International can serve as a replacement for primary clarification with a 90 percent smaller footprint and 50 percent less power usage. The rotating screen physically separates fine solids, with customizable removal rates up to 80 percent TSS, 60 percent BOD and 40 percent FOG from flow streams, reducing loading on downstream treatment processes, improving treatment capacity and efficiency, lowering operating costs, and increasing energy recovery in a very small footprint. **866/615-8130; www.hydro-int.com; Booth 3329.**



## InfoSense SL-RAT

The **Sewer Line Rapid Assessment Tool, or SL-RAT**, from InfoSense allows municipalities to save time, water and money by using active acoustics to provide a quick view of blockage conditions within gravity-fed sewers. The test takes three minutes with no flow contact, and allows technicians to inspect 10,000 to 20,000 feet per day with two people. The unit is EPA validated and GPS enabled. Data can be downloaded to the Sewer Line Data Organizer, or SL-DOG for archiving, visualization in Google Earth, or integration with enterprise/GIS applications. **877/747-3245; www.infosenseinc.com; Booth 1541.**



## JDV Equipment Level Loder

The **Level Loder** from JDV Equipment provides a means to dispose of processed waste and material with increased odor control and reduced risk of personnel being unnecessarily exposed to processed material. It helps contain odor by covering standard dumpsters used for hauling processed material, allowing for even distribution of material while increasing the fill percentage of the dumpster without the need for personnel to manually even out the waste material. It allows for outdoor installation with enhanced pest control measures without exposing material to the environment, freeing indoor square footage for other needs and allowing for a decrease in capital expenses for design, engineering and installation for new construction/upgrade projects. **973/366-6556; www.jdvequipment.com; Booth 3445.**



## JWC Environmental IFT Rotary Drum Sludge Thickener

The **IFT Rotary Drum Sludge Thickener** from JWC Environmental achieves 5 to 15 percent solids for municipal wastewater biosolids. The Rotary Drum Thickener uses woven wire mesh screening panels that allow for capture rates in excess of 98 percent and a much lower polymer use. The drums are constructed with easily removable panels for drum retrofit or repair. The IFT is also fully enclosed to control odors in the thickening area. The extremely short dwell time in the mixing tank drives a smaller equipment footprint and low polymer requirements. **800/331-2277; www.jwce.com; Booth 4516.**



## Keller America LevelRat

The **LevelRat** from Keller America proves that wastewater level transmitters don't need to be bulky, that nonstick diaphragms don't need to be large and fragile, lead times can be short, and that transmitters can be protected from lightning. It offers 0.5 percent FS TEB accuracy and dual outputs — analog and RS485 digital. Models equipped with a 4-20mA analog output include lightning protection carrying a lifetime guarantee against damage from electrical surge. **877/253-5537; www.kelleramerica.com; Booth 6446.**



## Komline-Sanderson Biosolids Drying System

**Biosolids Drying Systems** from Komline-Sanderson are capable of handling in excess of 1,000 tons of wet cake per day. Excess heat from combustion engines or turbines can be used to heat thermal fluid or produce steam. The dryer's shaft, hollow paddles and trough are all heated. The robust design and low speed with minimal rotating parts results in reduced maintenance costs. Indirect drying using the airtight dryer results in minimal off-gas volume, which





allows simplified odor control systems and safe operation resulting in reduced disposal costs for the beneficial reuse of biosolids as fertilizer and green fuel. **800/225-5457; [www.komline.com](http://www.komline.com); Booth 2229.**

### Lakeside Equipment Raptor



**Raptor Septage Acceptance Plants** and **Raptor Septage Complete Plants** from **Lakeside Equipment** are ideal for hauled liquid waste receiving. A successful hauled waste handling facility is dependent upon the type and quality of the upfront screening and grit removal system. Hauled waste receiving

generates consistent revenue, but only if the system is designed well. Properly screening the hauled waste allows the waste to be used more successfully in energy production or processed through the facility. **630/837-5640; [www.lakeside-equipment.com](http://www.lakeside-equipment.com); Booth 2918.**

### Neptune Chemical Pump Series MP7000

The **Series MP7000** mechanically actuated diaphragm metering pump from **Neptune Chemical Pump** eliminates the use of contour plates on the liquid side of the diaphragm, while the simple, straight-through valve and head design allows for improved flow characteristics. It is self-priming, and provides a maximum capacity range up to 27 gph at 235 psi. **215/699-8700; [www.neptune1.com](http://www.neptune1.com); Booth 519.**



### Nidec Motor Corporation U.S. Motors TITAN II 5000



**U.S. Motors TITAN II 5000** frame motors from **Nidec Motor Corporation** are made with robust cast iron construction to minimize internal stresses and vibration, and can withstand severe-duty applications. The motor was recently redesigned for increased flexibility and convertibility, and can be provided with a self-contained sleeve bearing system. **888/637-7333; [www.usmotors.com](http://www.usmotors.com); Booth 2945.**

### Penn Valley Pump Double Disc Pump

The **Double Disc Pump** from **Penn Valley Pump** provides a low life-cycle cost. The design eliminates the friction wear associated with progressive cavity and rotary lobe pump styles. The pump can run dry without damage and incorporates a sealing trunion that requires no maintenance, no seal water, no packing, no lubrication and does not leak. The company offers a free "Swap Your Pump" trial program that provides the opportunity to try the pump risk-free. **800/311-3311; [www.pennvalleypump.com](http://www.pennvalleypump.com); Booth 5229.**



### Perma-Liner InnerSeal Lateral Connection



The **InnerSeal Lateral Connection** system from **Perma-Liner** is an engineered CIPP solution for repairing the connection from the mainline while simultaneously renewing the lateral. It uses preformed hydrophilic rubber O-rings embedded between the host pipe and the liner to provide a permanent and verifiable non-leaking connection. This compression gasket seal is compatible with all types of piping that are common on manhole-to-manhole CIPP linings. It has been designed using the standard practice for rehabilitation of a sewer service lateral, ASTM-F2561. **866/336-2568; [www.perma-liner.com](http://www.perma-liner.com); Booth 4439.**

### PRIMEX PC-3000X



The **PRIMEX PC-3000X** controller is designed to operate up to three pumps in pump-up or pump-down applications. Intuitive menu navigation and quick setting adjustments are provided by a rotary selector wheel, back and escape buttons. The blue OLED display offers easy-to-read level readout and fault annunciation. When controlling the level in a tank, the input is connected to a 4-20mA sensor. It is configurable with no programming software required. A red LED indicates an active alarm, while green LEDs indicate the pumps required. It has multiple alternation configurations, bar graph levels and constant or variable speed control. **844/477-4639; [www.primexcontrols.com](http://www.primexcontrols.com); Booth 4339.**

### R.S. Technical Services TranSTAR II and TrakSTAR II

The combination of the **TranSTAR II** and **TrakSTAR II** from **R.S. Technical Services** delivers a high-power tractor and a compact pan-and-tilt zoom camera for inspection capability in lines 6 inches and larger in diameter and up to 3,000 feet in length. Dual 90-watt motors achieve speeds up to 70 feet per minute, with rapid freewheel retrieval, a tilt connection, rear view camera, adjustable LED lighting, and 10x optical/4x digital zoom. Optional elevator systems and multiple tire configurations are available. **800/767-1974; [www.rstechserv.com](http://www.rstechserv.com); Booth 1500.**



### RapidView IBAK North America 3D GeoSense



The **3D GeoSense** system from **RapidView IBAK North America** provides the power to map lateral pipelines with accuracy and speed. The sensor tracks the movement of the camera as it travels through the lateral, capturing distance, position and depth in three-dimensional space, and displayed by data logging software. It means technicians no longer have to track the system above ground with a locator, as they can simply conduct the inspection and collect the positional data. The system is ideal for cross-bore analysis. **800/656-4225; [www.rapidview.com](http://www.rapidview.com); Booth 7739.**

### Robuschi Robox Energy

The **Robox Energy** blower package from **Robuschi** and Gardner Denver is the first rotary screw blower package to be powered by an efficient permanent magnet motor. Pairing the permanent magnet motor with a rotary screw blower, the unit offers high-efficiency operation and wide turndown capability. Robuschi's Smart Process Control program offers further cost reduction by pairing the integral VFD with a PLC controller, delivering only the air you need, when you need it. It offers pressure operation to 15 psi, and flow rates to 1,450 cfm. **866/428-5253; [www.robuschiusa.com](http://www.robuschiusa.com); Booth 3317.**



### Seametrics iMAG 4700 Series



The NSF-61 approved **iMAG 4700 Series** flanged magnetometer from **Seametrics** is designed to fit anywhere from 4- to 12-inch pipe for usage in wastewater treatment plants, municipal and industrial water applications, pump skids, pump stations and packaged plants. It has mounted or remote display options, plus-or-minus 0.75 percent accuracy, minimal straight pipe requirements, various power and communication options, and user-changeable rate and total units. With three IP68-rated models to choose from, there's a unit for every budget and application. **800/975-8153; [www.seametrics.com](http://www.seametrics.com); Booth 653.**



## SEEPLEX ALPHA Systems

**SEEPLEX ALPHA Systems** are used in a variety of water and wastewater treatment chemical metering applications, including disinfection, chlorination, pH control, coagulation and flocculation. These plug-and-play packaged skid solutions eliminate much of the time and costs associated with engineering, procuring, assembling and installing flow control systems. They come in simplex, duplex or triplex pump configurations for floor or wall mounting. They are delivered complete with user-customized color display touch-screen controls and all necessary components for chemical metering packaged in a single unit. All wetted components are corrosion-resistant, including the self-priming NSF/ANSI 61 certified progressive cavity pumps, which provide precise, repeatable dosing with minimal pulsation and no vapor lock for chemical consumption reduction and byproduct minimization. **937/864-7150; www.seepex.com; Booth 1351.**



## Shand & Jurs 973XXT



The **973XXT** from **Shand & Jurs** is a candlestick waste gas flare with remote-tip ignition and touch-screen flare control box. The company offers a complete line of digester gas safety equipment including waste gas burners with touch-screen controls, electric drip traps, and radar gauges for municipal sewage treatment plants, landfills, dairies, food processing and breweries. **708/236-6000; www.sandj.com; Booth 1537.**

## Singer Valve LCP-TP

The **LCP-TP Level Controller** from **Singer Valve** is a single-process controller designed to complement the company's Single Solenoid Operated/Override Control Valves and sensor. It's programmed with customized level control algorithms and offers both local control via interactive display or remote control via 4-20mA or Serial Modbus SCADA communication. It has AC or DC external power options and contains a 24-volt DC internal power supply for PLC and field sensor power. It has an IP 67 enclosure rating and is UL certified, built with surge protection as well as overcircuit protection. It is equipped with data logging and trending features. **604/594-5404; www.singervalve.com; Booth 7129.**



## Smith & Loveless PISTA Vio Grit Removal System



The **PISTA Vio Grit Removal System** from **Smith & Loveless** provides design flexibility to go with removal efficiencies. It can be designed with the inlet and outlet channels at any variable angle up to the full 360 degrees of the chamber, offering simple installation into existing sites or an efficient footprint for new sites. With the use of a hydraulically forced ring and tunnel system, it creates the vortex flow path necessary to provide 95 percent grit removal down to 140 mesh/105 microns. **800/898-9122; www.smithandloveless.com; Booth 5539.**

## Superior Signal Smoke Candles

**Smoke Candles** from **Superior Signal** can help reduce wet weather SSOs and surface inflows. The company's smoke candles and blowers are engineered specifically for sewer testing. It is a fast, inexpensive and easy way to find the most common sources of surface inflows. Classic Smoke Candles provide a highly visible smoke to find



more faults, and at a longer distance. The 3C Classic Smoke Candle produces a volume of 40,000 cubic feet of smoke in just three minutes. Technicians can join multiple candles together to create larger volumes of smoke visible for a longer period of time. **800/945-8378; www.superiorsignal.com; Booth 3120.**

## Tank Connection Aqua AGT 2020

**Tank Connection** will introduce the latest addition to its line of coating products, **Aqua AGT 2020**. The company has combined its expertise in bolted RTP panel fabrication with experts in porcelain/vitreous enamel technologies to develop an advanced glass technology. This high-performance glass coating system addresses the deficiencies in today's glass coatings. It is superior in its formulation and two-fire process, exceeding AWWA D103 and EN ISO 28765:2016 requirements. **620/423-3010; www.tankconnection.com; Booth 1451.**



## Tideflex Technologies Mixing System

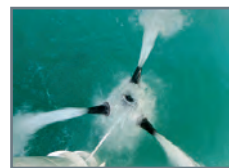

The **Tideflex Mixing System (TMS)** from **Tideflex Technologies** eliminates short-circuiting, water stagnation and achieves complete mixing in water storage tanks. Red Valve's engineering team developed a variable orifice inlet nozzle that provides superior mixing characteristics. When used in the TMS, Tideflex Variable Orifice Nozzles optimize jet velocity at all flow rates and discharge an elliptically shaped jet, which produces rapid and complete mixing that improves water quality. It separates the inlet and outlet with one manifold pipe, so short-circuiting is eliminated. **412/279-0044; www.tideflex.com; Booth 2639.**

## Total Piping Solutions Quick Cam Repair Clamp

The **Quick Cam Repair Clamp** from **Total Piping Solutions** is a wide-range high-performance clamp that uses a smart gasketing system to provide working pressures to 200 psi in diameters ranging from 2 to 42 inches. It is available in widths of 9, 12, 15, 23, 30 and 36 inches in length, and constructed of either 100 percent stainless steel materials or with an optional ductile iron lug system. **716/372-0160; www.tps.us; Booth 955.**



## Trumbull Industries Mud Valve



**Mud Valves** from **Trumbull Industries** are used in treatment plants to drain tanks for maintenance or cleaning. They provide trouble-free, low-maintenance operation. Each one receives a unique serial number stamp after passing inspection by quality assurance. In addition, they are certified for compliance with both NSF-61 and NSF-372, providing assurance that they are safe for use in a public water system. They are adaptable to specific needs with options including sliding stems and optional materials for seats, which are mechanically retained for ease of replacement. **800/677-1799; www.trumbull-mfg.com; Booth 5321.**

## Vac-Con Combination Machine

The full line of **Vac-Con Combination Machines** is available in configurations from 3.5- to 16-cubic-yard capacities, with hydrostatically driven two- and three-stage centrifugal compressors or several optional positive-displacement blowers. High-pressure, smooth-flow water systems are offered up to 120 gpm and 3,000 psi. These machines can be equipped with a 180-degree articulating front-mounted hose reel and high-pressure hose diameters from 5/8 to 1 1/4 inches. There are front- and rear-mounted telescopic booms available





with up to a 10-foot extension. In addition to pipe cleaning functions, units can double as vacuum excavators with the optional hydroexcavation package. 904/284-4200; [www.vac-con.com](http://www.vac-con.com); **Booth 7729.**

### Vactor 2100 Plus sewer cleaner



A water recycling system, available as an option for the **Vactor 2100 Plus** sewer cleaner configured with the positive-displacement blower, reuses water already in the sewer to clean sewer lines, eliminating the need for clean water. The user-friendly system delivers uninterrupted sewer line cleaning, enabling public utility and contractor professionals to clean more wastewater and sanitary lines in less time, without stopping to refill the water tank. A five-stage filtration system combines settling, centrifugal separation and absolute filtration to 100-micron particle sizes, preventing any abrasive solids from entering the jetting system. With no moving parts in the body or tanks, there is never a need to enter the body or tanks to maintain system components. 800/627-3171; [www.vactor.com](http://www.vactor.com); **Booth 4239.**

### Vaughan Company Triton

**Triton** screw centrifugal pumps from **Vaughan Company** handle thick biosolids, large or stringy solids, shear-sensitive fluids, and delicate or highly abrasive materials. They have non-overloading power characteristics, heavy-duty power frames and a flush-less mechanical seal. A water-flushed mechanical seal or packing is available. 888/249-2467; [www.chopperpumps.com](http://www.chopperpumps.com); **Booth 1516.**

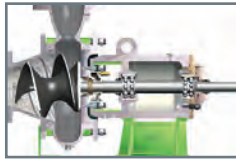

### VEGA Americas VEGAPULS WL 61



The **VEGAPULS WL 61** from **VEGA Americas** measures level and flow in a variety of settings, including wastewater processing plants, pump stations and overflow basins. Unaffected by extreme temperatures, high winds and heavy rains, it is a reliable level measurement solution that can measure through FOG, foam, condensation and other detriments to track level in water and wastewater facilities. 800/367-5383; [www.vega.com](http://www.vega.com); **Booth 163.**

### Vogelsang XRipper

**XRipper** twin-shaft grinders from **Vogelsang** effectively shred flushable wipes and tough material, preventing clogs and damage. They have high torque and low power usage; reduced maintenance, downtime and costs; no stack tightening; a repair-in-place design; and drop-in competitor replacement. 800/984-9400; [www.vogelsangusa.com](http://www.vogelsangusa.com); **Booth 619.**



### Watson-Marlow Fluid Technology Group Bredel



**Bredel** hose pumps from **Watson-Marlow Fluid Technology Group** reliably handle a variety of harsh materials, including abrasive sewage, making them ideal for feeding primary or thickened sludge to digesters or filter presses. Unlike other pump types, the highly abrasive nature of grit-filled sludge does not affect peristaltic hose pump life. With operating pressures to 232 psi and flow rates to 475 gpm, they eliminate ancillary equipment such as run-dry protection, seal water flush systems and inline check valves, and are virtually maintenance-free. 800/282-8823; [www.wmftg.com](http://www.wmftg.com); **Booth 4847.** ♦

## Sure is Fitting for the Environment!



### Large Diameter Electrofusion Fittings

- Diameters up to OD 48" IPS
- Easy installation in tight areas
- Pressure rated for natural gas and potable water applications
- Eliminates internal bead for increased flow
- Reduces operator errors
- Also available in metric sizes

### Sure-Grip®

#### Concrete Protective Liners

- Long service life
- Economical installation
- Low maintenance
- UV and chemical resistance
- Wide temperature range
- Abrasion resistant
- High back-pressure resistance
- Available in HDPE, PP, PVDF, and ECTFE



Please visit us at WEFTEC Booth #3959

[www.AgruAmerica.com](http://www.AgruAmerica.com)

800-373-2478 • [ads@agruamerica.com](mailto:ads@agruamerica.com)

This information is provided for reference purposes only and is not intended as a warranty or guarantee. Agru America, Inc. assumes no liability in connection with the use of this information.

NEW FROM MR MANHOLE

419-741-9075

# GOLD SERIES SIX SHOOTER



Increased Power



Increased Speed



Increased Durability

**Premier Manhole Cutter**  
[www.MrManhole.com/GOLD](http://www.MrManhole.com/GOLD)







## FAMHOST FAMILY OF INTEGRATED APPS

877-866-2588  
INFO@FAMHOSTAPPS.COM



Service Business Management Software



Secure Mobile Apps for Invoicing, Inventory, Bids



Phone Recording, Media Revenue Tracking



Any of your forms Online & Realtime



Digital Pen - Write on any paper form = digital



GPS - no contract Change Plans anytime



Link any Digital File to Your Customer Records



Strategic Bulk Email Marketing with stats



Integrated Email & Mail Marketing with Alerts



Device Management & Security Control System

SERVING THE INDUSTRY SINCE 1985 • CLOUD BASED SINCE 2000

## EVERYTHING UNDER CONTROL

PRIMEX® has everything under control by offering multiple production, engineering and sales facilities to ensure exceptional customer service through quick responsive quotes, submittals and delivery.

Our commitment to high standards in quality and new product development results in the broadest, most robust product line and services in the industry.

We design and build innovative solutions to meet your specific needs, no matter how unique:

- Arc Armor® control systems
- icontrol® SCADA solutions
- Complex system integration projects
- Premier and Express control panels
- 'View' and 'VPAC' family of pump controllers



ACE16 BOOTH 363



844-4PRIMEX (477-4639)

Ashland, OH | Clearwater, FL | Detroit Lakes, MN | Milford, OH | Plymouth, MN | Vacaville, CA

[WWW.PRIMEXCONTROLS.COM](http://WWW.PRIMEXCONTROLS.COM)

PRIMEX® and iControl® are trademarks of SJE-Rhombus®



### ARTHUR PRODUCTS CO.

ENGINEERED SOLUTIONS



## Designed & Manufactured by Arthur Products Co.

1.800.322.0510  
apc@apclsq.com  
[www.arthurproducts.com](http://www.arthurproducts.com)



# COMPLETE SHORING SOLUTIONS

from  
**Design**  
to  
**Delivery**

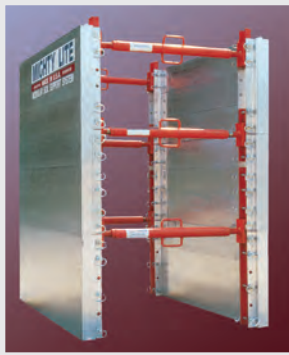

## American Shoring is the Leader in High Quality, Modular Trench Shoring

A complete line of heavy duty and light weight aluminum or steel trench shoring is available for all your needs.

Our staff is waiting for your call with professional advice to recommend the best specific product for your project.

Field service support and supervision available with on site assembly and take down.

Inquire about our Competent Person, Confined Space & OSHA 10 training classes.

*All systems are manufactured in the USA*

# AMERICAN SHORING INC.

207 LAKE STREET  
NEWBURGH, NY 12550

**1.800.407.4674**  
[www.americanshoring.com](http://www.americanshoring.com)

E-Mail us at  
[sales@americanshoring.com](mailto:sales@americanshoring.com)

**SALES • RENTALS • SERVICE  
REPAIRS • TRADE-INS  
RECERTIFICATION**

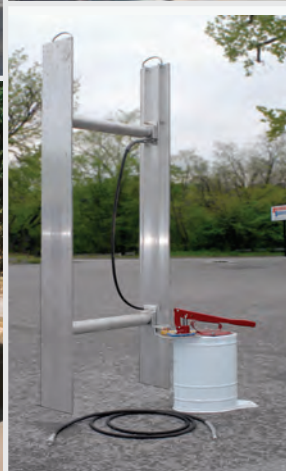



## MAPPING LATERALS IN REAL TIME

RapidView IBAK North America's 3-D GeoSense program maps while you inspect

By Luke LeNoble

Painting an accurate picture of all your underground assets can be both challenging and time-consuming. But a new technology on display at the Water & Wastewater Equipment, Treatment & Transport Show aims to be a real time-saver for municipalities that need to get a detailed visual of the labyrinth of sewer laterals connecting into their systems.

3-D GeoSense from RapidView IBAK North America allows municipalities to map lateral pipelines quickly and accurately in real time while performing a standard camera inspection.

"A lot of cities will maintain a GIS map of all their mainlines," says Matt Sutton, vice president of sales and marketing for RapidView IBAK North America. "Now, we can start to add the laterals to this. Because we've put a sensor on the front of the camera, we can map the lateral as the pushrod moves through the lateral in three-dimensional space.

"More and more cities are interested in and responsible for the lateral connection from the mainline to the customer's house, and having an accurate map — what that lateral looks like — does a lot of different things."

The unit can be used in push or lateral launch applications. A built-in sensor tracks the movement of the camera as it travels through the lateral, capturing distance, position and depth. The XYZ coordinates can be recorded when the camera is moving both forward and backward. Data is captured and displayed by third-party data logging software, such as WinCan VX.

"It could be part of their normal process," Sutton says. "So when they look at the lateral visually with a camera, at the same time they are creating a three-dimensional file that can go right over their GIS, and they can have a three-dimensional model of their entire infrastructure."

As a result, municipalities no longer have to locate laterals with an above-ground locator, making 3-D GeoSense an effective tool for cross-bore analysis.

"It's very useful for utilities," Sutton says. "If you have to dig, you know exactly



**Matt Sutton, vice president of sales and marketing for RapidView IBAK North America, explains the operation of the 3-D GeoSense program to a group of attendees on the 2016 WWETT Show floor. The program allows municipalities to map lateral lines quickly and accurately in real time while performing a standard camera inspection. (Photo by Luke LeNoble)**

where it is. If it's a gas boring company that has to drill through that neighborhood, they could know within inches exactly where they need to drill without hitting one of these sewer lines and causing potentially a big problem."

Configured to work with the new LISY 3.2 or MiniLite pushrod systems, the module can also be installed on the ORION, ORION-L or POLARIS camera systems.

"This is the first time anybody is seeing it live," Sutton says of the lateral mapping system. "They are amazed. People have wanted this for the last 10 years."

What took so long to bring this technology to market? "The sophistication of the electronics to get small enough to go inside some of the camera systems," he says. "Our stuff is typically very complex and compact. But we were able to make a sensor that was small enough to fit in our already small cameras that could go into a 3-inch lateral.

"The show's been great this year," Sutton says. "We doubled our booth size this year, and we've about doubled our contacts with customers, which is amazing. I didn't know that was going to be the case."

Sutton says the WWETT Show is the ideal place to showcase new technology for the sewer and water industry, especially inspection cameras.

"In the United States, this is the show to go to for camera technology," he says. "There are other wastewater shows, but for our market and our customers, they are at this show, and they are looking for our type of products here. That's why we come." 800/656-4225; [www.rapidview.com](http://www.rapidview.com). ♦



# wwett<sup>™</sup>17

IT'S THE INDUSTRY  
EVENT OF THE YEAR



The WWETT Show - Water & Wastewater Equipment, Treatment & Transport - is the world's largest annual trade show for environmental service professionals. Over 10,000 attendees will gather from across the U.S. and beyond to see the latest in equipment and technology in the expo hall, participate in over 100 education sessions, and network with professional colleagues.

Sign up today at [www.wwettshow.com](http://www.wwettshow.com), and we'll notify you when registration opens this October.

**Conference:**  
**February 22-24, 2017**

**Exhibits:**  
**February 23-25, 2017**

Indiana Convention Center, Indianapolis, IN

[www.wwettshow.com](http://www.wwettshow.com)





800-257-7222  
715-546-3346  
WWW.MSWMAG.COM

# MUNICIPAL SEWER & WATER™

## 2017 BUYER'S GUIDE

» A Directory of Municipal Sewer & Water  
Manufacturers and Suppliers

### » Alphabetical Listings

**3T Equipment Company Inc.**  
PO Box 7325  
Santa Rosa, CA 95407  
800-969-3001 • 707-543-8555 • Fax: 707-543-8558  
tfequip@yahoo.com  
www.3tequipco.com  
**Ad on page 115**

### A

**A.W. Cook Cement**  
242 Amy Industrial Ln.  
Hoschton, GA 30548  
706-654-4706 • Fax: 706-654-3662  
cookcement@windstream.net  
www.awcookcement.com  
**Ad on page 147**

**AA Thread Seal Tape, Inc.**  
1275 Kyle Ct.  
Wauconda, IL 60084  
800-537-7139 • 847-526-2120 • Fax: 847-526-2209  
ryan@aatread.com  
www.aatread.com  
**Ad on page 148**

**Abart Industries, LLC**  
PO Box 864  
Skaneateles, NY 13152  
315-730-2588  
dave@tophatrisers.com  
www.tophatrisers.com  
**Ad on page 144**

**ABS Materials, Inc.**  
1909 Old Mansfield Rd  
Wooster, OH 44691  
330-234-7999  
info@absmaterials.com  
www.abswastewater.com  
**Ad on page 148**

**ADS LLC**  
340 The Bridge St., Ste. 204  
Huntsville, AL 35806  
800-633-7246 • 256-430-3366 • Fax: 256-430-6633  
adsales@idexcorp.com  
www.adsenv.com  
**Ad on page 29**

**Advanced Aquatic Products  
International, Inc.**  
18495 S Dixie Hwy., #161  
Cutler Bay, FL 33157  
800-738-7646 • 305-388-7195 • Fax: 305-388-7196  
advaquaticprods@aol.com  
www.hydro-cartridge.com  
**Ad on page 107**

  
**Advanced Drainage Systems, Inc. - ADS**  
4640 Trueman Blvd.  
Hilliard, OH 43026  
800-773-7473  
www.ads-pipe.com

**Advanced Infrastructure Technologies, LLC**  
3055 Kashiwa St.  
Torrance, CA 90505  
844-669-9537 • 310-534-4000 • Fax: 310-534-4020  
jp@advancedworld.com  
www.advancedworld.com  
**Ad on page 8**

**Agru America, Inc.**  
500 Garrison Rd.  
Georgetown, SC 29440  
800-373-2478 • 843-546-0600 • Fax: 843-527-2738  
salesmkg@agruamerica.com  
www.agruamerica.com  
**Ad on page 55**

**American Highway Products, Ltd.**  
11723 Strasburg Bolivar Rd. NW  
Bolivar, OH 44612  
888-272-2397 • 330-874-3270 • Fax: 330-874-3800  
sales@ahp1.com  
www.ahp1.com  
**Ad on page 97**

**American Jetter**  
6908 Pine Grove Dr.  
Knoxville, TN 37914  
866-944-3569 • 865-524-4647 • Fax: 865-247-5105  
andy@americanjetter.com  
www.americanjetter.com  
**Ad on page 148**

**American Pleasure Products, Inc.**  
2823 E Industrial Dr.  
Rose City, MI 48654  
989-685-2697 • Fax: 989-685-8484  
info@aquacycleusa.com  
www.aquacycleusa.com  
**Ad on page 111**

**American Shoring, Inc.**  
207 Lake St.  
Newburgh, NY 12550  
800-407-4674 • 845-562-4477 • Fax: 800-361-1973  
ajhull@americanshoring.com  
www.americanshoring.com  
**Ad on page 57**

  
**AMT Pump Company**  
400 Spring St.  
Royersford, PA 19468  
610-948-3800 • Fax: 610-948-5300  
sales@amtump.com  
www.amtump.com  
**Ad on page 83**

**Anthrafilter U.S., Inc.**  
4992 Sweet Home Rd.  
Niagara Falls, NY 14305  
800-998-8555 • 716-285-5680 • Fax: 716-285-5681  
swilley@anthrafilter.net  
www.anthrafilter.net  
**Ad on page 147**

**AP/M Permaform**  
PO Box 555  
Johnston, IA 50131  
800-662-6465 • 515-276-9610 • Fax: 515-276-1274  
info@permaform.net  
www.permaform.net  
**Ad on page 67**



Advertisers in the magazine are listed in blue and bolded.



**Applied Felts, Inc.**  
450 College Dr.  
Martinsville, VA 24112  
276-656-1904 • Fax: 276-656-1909  
info@appliedfelts.com  
www.appliedfelts.com  
**Ad on page 9**



**Aqua Operations, Inc.**  
PO Box 9956  
Bakersfield, CA 93389  
888-746-6535 • 661-331-1181 • Fax: 661-833-1861  
operator@aquaoptions.com  
www.aquaoptions.com  
**Ad on page 146**



**Aqualitec Corp.**  
3415 S Sepulveda Blvd., Ste. 1100  
Los Angeles, CA 90034  
855-650-2214  
info@aqualitec.com  
www.aqualitec.com



**Aries Industries, Inc.**  
550 Elizabeth St.  
Waukesha, WI 53186  
800-234-7205 • 262-896-7205  
sales@ariesindustries.com  
www.ariesindustries.com  
**Ad on page 123**



**Arthur Products Co.**  
1140 Industrial Pkwy.  
Medina, OH 44256  
800-322-0510 • 330-725-4905 • Fax: 330-722-2698  
apcc@apdsq.com  
www.arthurproducts.com  
**Ad on page 56**

**Avanti International**  
1100 Hercules Ave., Ste. 320  
Houston, TX 77058  
800-877-2570 • 281-486-5600 • Fax: 281-486-7300  
sales@avantigrout.com  
www.avantigrout.com

**B**

**Best Management Products, Inc.**  
53 Mt. Archer Rd.  
Lyme, CT 06371  
800-504-8008 • 410-687-6256 • Fax: 877-434-3197  
tjm@bmpinc.com  
www.bmpinc.com  
**Ad on page 24**

**BioAir Solutions LLC**  
110 Kresson-Gibbsboro Rd., Ste. 303  
Voorhees, NJ 08043  
856-258-6969 • Fax: 856-258-6975  
cwest@bioairsolutions.com  
www.bioairsolutions.com

**Bionetix International**  
21 040 Rue Daoust  
Ste-Anne-de-Bellevue, QC H9X 4C7  
Canada  
514-457-2914 • Fax: 514-457-3589  
info@bionetix.ca  
www.bionetix-international.com



**Blue-White Industries**  
5300 Business Dr.  
Huntington Beach, CA 92649  
714-893-8529 • Fax: 714-894-9492  
sales@blue-white.com  
www.blue-white.com  
**Ad on page 17**

**Boerger, LLC**  
2860 Water Tower Pl.  
Chanhassen, MN 55317  
612-435-7300 • Fax: 612-435-7301  
america@boerger.com  
www.boerger.com

**BRIGHT DYES - Division of Kingscote Chemicals**  
3334 S Tech Blvd.  
Miamisburg, OH 45345  
800-394-0678 • 937-886-9100 • Fax: 937-886-9300  
sales@kingscotechemicals.com  
www.brightdyes.com  
**Ad on page 145**

**C**

**Cam Spray**  
520 Brooks Rd.  
Iowa Falls, IA 50126  
800-648-5011 • 641-648-5011 • Fax: 641-648-5013  
sales@camspray.com  
www.camspray.com  
**Ad on page 38**

**CCI Pipeline Systems**  
1058 O'Neal Dr.  
Breaux Bridge, LA 70517  
800-867-2772 • 337-332-5808 • Fax: 337-332-5809  
sales@ccipipe.com  
www.ccipipe.com



**CHEMetrics, Inc.**  
4295 Catlett Rd.  
Midland, VA 22728  
800-356-3072 • 540-788-9026 • Fax: 540-788-4856  
sales@chemetrics.com  
www.chemetrics.com

**Chempace Corporation**  
339 Arco Dr.  
Toledo, OH 43607  
800-423-5350 • 419-535-0101 • Fax: 419-535-0531  
vhorvath@chempace.com  
www.chempace.com  
**Ad on page 46**

**Clean Water Works Inc.**  
1800 Bantree St.  
Ottawa, ON K1B 5L6  
Canada  
866-695-0155 • 613-745-2444 • Fax: 613-745-9994  
kpeori@cwvcanada.com  
www.cwvcanada.com

**Cloverleaf Tool Co.**  
PO Box 110757  
Bradenton, FL 34211  
800-365-6583 • 941-739-0707 • Fax: 941-739-0001  
sales@cloverleaftool.com  
www.cloverleaftool.com  
**Ad on page 115**

**Comet USA**  
1601 Hwy. 13 E  
Burnsville, MN 55337  
800-708-1894 • 952-707-1894 • Fax: 952-707-1895  
cometpump@cometpump.com  
www.cometpump.com

**Cortec Corporation**  
4119 White Bear Pkwy.  
St. Paul, MN 55110  
651-429-1100 • Fax: 651-429-1122  
info@cortecvci.com  
www.cortecvci.com

**Cretex Specialty Products**  
N16 W23390 Stoneridge Dr., Ste. A  
Waukesha, WI 53188  
800-345-3764 • 262-542-8153 • Fax: 262-542-0301  
info@cretexseals.com  
www.cretexseals.com  
**Ad on page 24**

**Cua Claws**  
2376 Maize Rd.  
Twentynine Palms, CA 92277  
714-697-8697  
jerry@cuaclaws.com  
www.cuaclaws.com  
**Ad on page 145**



**CUES**  
3600 Rio Vista Ave.  
Orlando, FL 32805  
800-327-7791 • 407-849-0190 • Fax: 407-425-1569  
salesinfo@cuesinc.com  
www.cuesinc.com  
**Ad on page 15**

**Custom Manufacturing, Inc.**  
4101 SW 113th St.  
Oklahoma City, OK 73173  
888-692-6311 • 405-692-6311 • Fax: 405-691-8190  
jamie@custommanufacturing.us  
www.custommanufacturing.us

**D**

**Data Flow Systems, Inc.**  
605 N John Rodes Blvd.  
Melbourne, FL 32934  
321-259-5009 • Fax: 321-259-4006  
www.dataflowsys.com  
**Ad on page 147**

**Ditch Witch**  
1959 W Fir Ave.  
Perry, OK 73077  
800-654-6481 • 580-336-4402  
info@ditchwitch.com  
www.ditchwitch.com

**Duke's Root Control, Inc.**  
1020 Hiawatha Blvd. W  
Syracuse, NY 13204  
800-447-6687 • 315-472-4781 • Fax: 315-475-4203  
lynn@dukes.com  
www.dukes.com  
**Ad on page 13**

**Dultmeier Sales**  
13808 Industrial Rd.  
Omaha, NE 68137  
800-228-9666 • 402-333-1444 • Fax: 402-333-5546  
mhansen@dultmeier.com  
www.dultmeier.com

**Dynamic Repairs**  
40 Arnot St., Unit 20  
Lodi, NJ 07644  
973-478-0893 • Fax: 973-478-0895  
dynamicablerepairs@yahoo.com  
www.dynamicrepairs.biz  
**Ad on page 145**



## E

**Efficiency Production, Inc.**

685 Hull Rd.  
Mason, MI 48854  
800-552-8800 • 517-676-8800 • Fax: 517-676-0373  
jmcroy@efficiencyproduction.com  
www.efficiencyproduction.com

Ad on page 32

**Eldred Environmental & Export Co. LTD**

1275 W 11th St.  
Milan, IL 61264  
800-613-3640 • 309-787-3640 • Fax: 309-787-3635  
info@fol-da-tank.com  
www.eldredenvironmental.com

**Electric Eel Mfg.**

501 W Leffel Ln.  
Springfield, OH 45501  
800-833-1212 • 937-323-4644 • Fax: 937-323-3767  
info@electriceel.com  
www.electriceel.com

Ad on page 146

**Electro Scan Inc.**

1745 Markston Rd.  
Sacramento, CA 95825-4026  
800-975-6149 • 916-779-0660 • Fax: 916-779-0661  
info@electroscan.com  
www.electroscan.com

Ad on page 153

**THE SHOOTER®**

**Emagineered Solutions, Inc.**  
527 NW Elm Ave., Ste. 3-405  
Redmond, OR 97756  
541-504-0416 • Fax: 541-504-0417  
ray.i@emagineered.com  
www.theshooteripp.com

**Endress+Hauser**

2350 Endress Pl.  
Greenwood, IN 46143  
888-363-7377 • Fax: 317-535-8498  
info@us.endress.com  
www.us.endress.com

**Enviro-Care Company**

1570 St. Paul Ave.  
Gurnee, IL 60031  
815-636-8306 • Fax: 847-672-7968  
ecsales@enviro-care.com  
www.enviro-care.com

**Environmental Coatings LLC**

4702 E Virginia St.  
Mesa, AZ 85215  
480-984-7608 • Fax: 480-380-4461  
info@sewershield.com  
www.sewershield.com

**Environmental Rental Services LTD**

PO Box 192  
Rockdale, TX 76567  
512-446-7011 • Fax: 512-446-7195  
sterling@ersvacrent.com  
www.ersvacrent.com

Ad on page 148

**Envirosight**

111-B3 Canfield Ave.  
Randolph, NJ 07869  
866-936-8476 • 973-252-6700 • Fax: 973-252-1176  
mail@envirosight.com  
www.envirosight.com

Ad on page 2

**Enz USA, Inc.**

1585 Beverly Ct., Unit 115  
Aurora, IL 60502  
877-369-8721 • 630-692-7880 • Fax: 630-692-7885  
sales@enzusainc.com  
www.enzusainc.com

Ad on page 77

**Exact Pipe Tools**

141 Broad Blvd., Ste. 201  
Cuyahoga Falls, OH 44221  
844-392-2800 • 330-922-8150 • Fax: 888-607-9648  
nasales@exacttools.com  
www.exacttools.com

**EZ Rig Crane**

1500 Palma Dr., 2nd Floor  
Ventura, CA 93003  
844-395-4387 • 805-643-4387 • Fax: 805-642-9925  
info@ezrigcrane.com  
www.ezrigcrane.com

## F

**Famhost**

245 N. Waco St., Ste. 230  
Wichita, KS 67211  
800-658-1676 • 316-267-9910 • Fax: 800-858-2397  
info@famhostapps.com  
www.famhost.com

Ad on page 56

**Ferguson Waterworks**

12500 Jefferson Ave.  
Newport News, VA 23602  
757-874-7795  
bryan.mokry@ferguson.com  
www.ferguson.com/waterworks

Ad on page 49

**Ferratex, Inc.**

20520 Unico Rd.  
McKenney, VA 23872  
804-451-3667 • Fax: 804-478-8296  
justing@ferratex.com  
www.ferratex.com

**FlowMark Vacuum Trucks**

610 S Adams St.  
Kansas City, KS 66105  
855-653-8100 • 913-653-8103 • Fax: 913-653-8101  
sales@flowmark.com  
www.flowmark.com

Ad on page 79

**FlowWorks Inc.**

606 Maynard Ave. S, Ste. 251  
Seattle, WA 98104  
206-859-6999 • Fax: 206-320-9939  
sales@flowworks.com  
www.flowworks.com

**Flygt - a Xylem Brand**

14125 S Bridge Cir.  
Charlotte, NC 28134  
855-995-4261  
www.xylem.com/pumping

**Footage Tools, Inc.**

1-54 Audia Ct.  
Vaughan, ON L4K 3N4  
Canada  
888-737-3668 • Fax: 905-695-8874  
bf@footage.ca  
www.footagetools.com

Ad on page 146

**Formadrain, Inc.**

10121 Parkway  
Montreal, QC H1J 1P7  
Canada  
888-337-6764  
info@formadrain.com  
www.formadrain.com

Ad on page 135

## G

**GapVax, Inc.**

575 Central Ave.  
Johnstown, PA 15902  
888-442-7829 • 814-535-6766 • Fax: 814-539-3617  
inquiry@gapvax.com  
www.gapvax.com

Ad on page 155

**General Pipe Cleaners**

1101 Thompson Ave.  
McKees Rocks, PA 15136  
800-245-6200 • 412-771-6300  
info@drainbrain.com  
www.drainbrain.com

**General Pump**

1174 Northland Dr.  
Mendota Heights, MN 55120  
888-474-5487 • 651-454-6500 • Fax: 651-454-8015  
sales@gpcompanies.com  
www.generalpump.com

**Generator-Parts.com**

PO Box 816  
Three Lakes, WI 54562  
715-546-2244  
sales@generator-parts.com  
www.generator-parts.com

Ad on page 147

**Giant Industries**

900 N Westwood Ave.  
Toledo, OH 43607  
800-633-4565 • 419-531-4600 • Fax: 419-531-6836  
sales@giantpumps.com  
www.giantpumps.com

**Gorman-Rupp Company**

600 S Airport Rd.  
Mansfield, OH 44903  
419-755-1011 • Fax: 419-755-1251  
grsales@gormanrupp.com  
www.GRpumps.com

## H

**Hach - Flow Products & Services**

5600 Lindbergh Dr.  
Loveland, CO 80538  
800-368-2723  
www.hachflow.com

**Hammelmann Corp.**

436 Southpointe Dr.  
Dayton, OH 45342  
800-783-4935 • 937-859-8777 • Fax: 937-859-9188  
mail@hammelmann.com  
www.hammelmann.com

**HammerHead Trenchless Equipment**

500 South C.P. Ave.  
Lake Mills, WI 53551  
800-331-6653 • 920-648-4848  
jhaas@hammerheadmole.com  
www.hammerheadtrenchless.com

Ad on page 45

**HARCO Fittings**

3721 Cohen Pl.  
Lynchburg, VA 24501  
434-845-7094 • Fax: 434-845-8562  
sales@harcofittings.com  
www.harcofittings.com

Ad on page 148

**Hastings Irrigation Pipe Co.**

1801 E South St.  
Hastings, NE 68902  
800-759-8823 • Fax: 402-463-4355  
giones@hipco-ne.com  
www.hastingsirrigation.com

**Hawk Measurement America**

96 Glenn St.  
Lawrence, MA 01843  
888-429-5538 • 978-304-3000 • Fax: 978-304-1462  
info@hawkmeasure.com  
www.hawkmeasure.com

**Helix Laboratories, Inc.**

1110 Cline  
Corpus Christi, TX 78418  
877-444-3549  
info@helixlabs.com  
www.helixlabs.com

Ad on page 63

**HEMCO Corporation**

711 S Powell Rd.  
Independence, MO 64056  
800-779-4362 • 816-796-2900 • Fax: 816-796-3333  
info@hemcocorp.com  
www.hemcocorp.com

Ad on page 146



**Hermann Sewerin GmbH**

Robert-Bosch-Str.3  
D-33334 Gutersloh  
Germany  
888-592-9916 • Fax: 49524193444  
sewerin-usa@sewerin.net  
www.sewerin.com

**Hi-Vac Corporation**

117 Industry Rd.  
Marietta, OH 45750  
800-752-2400 • Fax: 740-374-2306 • Fax: 740-374-5447  
sales@x-vac.com  
www.x-vac.com  
**Ad on page 151**

**Hidrostal Pumps**

2225 White Oak Cr.  
Aurora, IL 60502  
630-948-3355 • Fax: 630-948-3353  
info@hidrostalpumps.com  
www.hidrostalpumps.com

**Hot Jet USA**

14773 Heritage Crest Way  
Riverton, UT 84065  
800-624-8186 • 801-545-0777  
sales@powerlineindustries.com  
www.hotjetusa.com  
**Ad on page 147**



**Hurco Technologies, Inc.**

409 Enterprise St.  
Harrisburg, SD 57032  
800-888-1436 • 605-743-2466  
info@hurcotech.com  
www.hurcotech.com  
**Ad on page 20**

**Hydra-Flex, Inc.**

980 Lone Oak Rd., Ste. 128  
Eagan, MN 55121  
952-808-3640 • Fax: 952-808-3650  
sales@hydraflexinc.com  
www.hydraflexinc.com  
**Ad on page 144**

**Hydra-Stop**

144 Tower Dr., Ste. A  
Burr Ridge, IL 60527  
800-538-7867 • 708-389-5111 • Fax: 708-389-5125  
dchristensen@idexcorp.com  
www.hydra-stop.com

**HydraTech Engineered Products**

10488 Chester Rd  
Cincinnati, OH 45215  
513-827-9169 • Fax: 513-827-9171  
info@hydrattechllc.com  
www.hydrattechllc.com  
**Ad on page 145**

**I**

**ICS - Blount Inc.**

4909 SE International Way  
Portland, OR 97222  
800-321-1240 • Fax: 503-653-4393  
marketing@icsdiamondtools.com  
www.icsdiamondtools.com



**Indusco Environmental Services, Inc.**

PO Box 8093  
Spanish Fort, AL 36577  
251-621-2338  
sales@induscoenviro.com  
www.induscoenviro.com  
**Ad on page 146**

**Informa Exhibitions**

6191 N St. Hwy. 161, Ste. 500  
Irving, TX 75038  
972-536-6477  
danny.green@informa.com  
www.informalexhibitions.com  
**Ad on page 59**

**InfoSense, Inc.**

8116 S Tryon St., Ste. B3-203  
Charlotte, NC 28273  
877-747-3245 • 704-644-1164 • Fax: 704-930-0145  
achurchill@infosenseinc.com  
www.infosenseinc.com  
**Ad on page 95**

**Infrastructure Repair Systems Inc.**

4301 A 34th St. N  
St. Petersburg, FL 33714  
877-327-4216 • Fax: 727-327-4118  
irsi@irsi.net  
www.irsi.net  
**Ad on page 46**

**Inliner Technologies**

1468 W Hospital Rd.  
Paoli, IN 47454  
812-723-0704  
info@inliner.com  
www.inliner.com  
**Ad on page 23**

**IPEX Inc.**

1425 N Service Rd E., Unit 3  
Oakville, ON L6H 1A7  
Canada  
800-463-9572 • 289-881-0120 • Fax: 905-844-1504  
www.ipexamerica.com  
**Ad on page 125**

**No-Risk Trial!**

**1**

Digests F.O.G. in waste tank for easier disposal.

**2**

Creates biofilm to inhibit future F.O.G. buildup.

**3**

Prevents F.O.G. from reattaching downstream.

**4**

Breaks up F.O.G. deposits to improve jetting.

**Don't Just Jet Grease, Devour It.**

**JetBugs** | JetBugs combines chemical & microbial degreasers to supercharge sewer jetting, helping preventing SSOs and backups.

**HELIX LABORATORIES, INC.**

(877) 444-3549 • helixlabs.com

**grease & odor control experts**



## IPEX USA LLC

10100 Rodney St.  
Pineville, NC 28134  
800-463-9572 • 704-889-2431 • Fax: 905-844-0826  
sales@ipexamerica.com  
www.enduragrease.com

## J



## J. Hvidtved Larsen US

J. Hvidtved Larsen US, Inc.  
John Hancock Center-875 N Michigan Ave., Ste. 3950  
Chicago, IL 60611  
312-705-3818  
jhl@hvidtved.com  
www.hvidtved.com

## Jack Doheny Companies

777 Doheny Dr.  
Northville, MI 48167  
800-336-4369 • 248-349-0904 • Fax: 248-349-2774  
info@dohenycompanies.com  
www.dohenycompanies.com

## JD7 Technologies

7710 Kenamar Ct  
San Diego, CA 92121  
858-242-1640 • Fax: 858-242-1655  
info@jd7usa.com  
www.jd7usa.com



## Joe Johnson Equipment, Inc.

2521 Bowman St.  
Innisfil, ON L9S 3V6  
Canada  
800-263-1262 • 705-733-7700 • Fax: 707-733-8800  
info@jjei.com  
www.jjei.com

## JPCI Services

4702 E Virginia St.  
Mesa, AZ 85215  
480-986-1212 • Fax: 480-380-4461  
info@jpciservices.com  
www.jpciservices.com

## JWC Environmental

2850 S. Red Hill Ave. Ste. 125  
Santa Ana, CA 92705  
800-331-2277 • 949-833-3888 • Fax: 714-428-4644  
jwce@jwce.com  
www.jwce.com  
Ad on page 32

## K



## K&amp;W Products, Inc.

26264 US Hwy. 98  
Elberta, AL 36530  
800-503-0076 • 251-986-7900 • Fax: 251-986-7902  
sales@kwproducts.net  
www.kwmiequipment.com  
Ad on page 147

## KEG Technologies, Inc.

6220 N Pinnacle Dr.  
Spartanburg, SC 29303  
866-595-0515 • 864-804-6637 • Fax: 864-804-6629  
sales@kegtechnologies.net  
www.kegtechnologies.net  
Ad on page 107

## KOHLER Power Systems

444 Highland Dr.  
Kohler, WI 53044  
800-544-2444 • 920-457-4441 • Fax: 920-459-1646  
generator.feedback@kohler.com  
www.kohlerpower.com

## Komline-Sanderson

12 Holland Ave.  
Peapack, NJ 07977  
800-225-5457 • 908-234-1000 • Fax: 908-234-9487  
info@komline.com  
www.komline.com  
Ad on page 65

## Krausz USA

331 SW 57th Ave.  
Ocala, FL 34474  
855-457-2879 • Fax: 352-304-5787  
mary.pfeiffer@krauszusa.com  
www.krauszusa.com  
Ad on page 81

## L



## LADTECH, Inc.

6704 Meadowlark Ct.  
Lino Lakes, MN 55038  
877-235-7464 • 651-415-1252 • Fax: 651-415-1090  
adjring@ladtech.com  
www.ladtech.com  
Ad on page 85

## Lametti &amp; Sons

16028 Forest Blvd. N  
Hugo, MN 55038  
651-426-1380  
bretta@lametti.com  
www.lametti.com



## Lansas Mfg. by Vanderlans &amp; Sons Inc.

1320 S Sacramento St.  
Lodi, CA 95240  
800-452-4902 • 209-334-4115 • Fax: 209-339-8260  
sales@lansas.com  
www.lansas.com

## Layne Inliner

4520 N State Rd. 37  
Orleans, IN 47452  
812-865-3232  
heavycivilinfo@layne.com  
www.layne.com/inliner

## Lee Supply Company

305 1st St.  
Charleroi, PA 15022  
800-353-3747 • 724-483-3543 • Fax: 724-483-0577  
info@leesupply.com  
www.leesupply.com  
Ad on page 12



## Legacy Building Solutions

19500 County Rd. 142  
South Haven, MN 55382  
877-259-1528 • 320-258-0500  
legacy@legacybuildingsolutions.com  
www.legacybuildingsolutions.com



## Liberty Pumps

7000 Apple Tree Ave.  
Bergen, NY 14416  
800-543-2550 • 585-494-1817 • Fax: 585-494-1839  
laurie.pfaff@libertypumps.com  
www.libertypumps.com

## LIFTPLAQ US LLC

18001 Old Cutler Rd  
Palmetto Bay, FL 33157  
786-600-1843 • Fax: 855-220-2429  
llc@liftplaq.us  
www.liftplaq.us  
Ad on page 147

## Light Ring Inc.

530 Dubois Ave.  
McCallsburg, IA 50154  
877-941-2833 • 515-290-8295 • Fax: 515-434-2249  
shane@lightringinc.com  
www.lightringinc.com  
Ad on page 148



## Linabond, Inc.

1161 Avenida Acaso  
Camarillo, CA 93012  
805-484-7373  
info@linabond.com  
www.linabond.com

## Liner Products

1468 W Hospital Rd.  
Paoli, IN 47454  
812-723-0244  
info@linerproducts.com  
www.linerproducts.com

## LMK Technologies

1779 Chessie Ln.  
Ottawa, IL 61350  
815-433-1275 • Fax: 815-433-0107  
info@lmktechnologies.com  
www.lmktechnologies.com  
Ad on page 143

## Logiball, Inc.

440 Papin St.  
Quebec, QC G1P 3T9  
Canada  
800-246-5988 • 418-656-9767 • Fax: 418-653-5746  
info@logiball.com  
www.logiball.com/en

## M

## Matchpoint Water Asset Management, Inc.

215 Racine Dr. Ste. 201  
Wilmington, NC 28403  
910-509-7225 • 910-509-7226  
info@matchpointinc.us  
www.matchpointinc.us  
Ad on page 133

## McCrometer Inc.

3255 W Stetson Ave.  
Hemet, CA 92545  
800-220-2279 • 951-652-6811 • Fax: 951-652-3078  
customerservice@mccrometer.com  
www.mccrometer.com

## McElroy Manufacturing, Inc.

PO Box 580550  
Tulsa, OK 74158  
918-836-8611 • Fax: 918-831-9285  
smcelroy@mcelroy.com  
www.mcelroy.com

## McGard LLC

3875 California Rd.  
Orchard Park, NY 14127  
888-888-9192 • 716-662-8980 • Fax: 716-662-8985  
rglass@mcgard.com  
www.manholelocks.com  
Ad on page 87

## McLaughlin Group

2006 Perimeter Rd.  
Greenville, SC 29605  
800-435-9340 • 864-277-5870 • Fax: 864-235-9661  
mmole@mightymole.com  
www.mclaughlinunderground.com

## Miller Pipeline

8850 Crawfordsville Rd.  
Indianapolis, IN 46234  
800-428-3742 • 317-293-0278  
www.millerpipeline.com  
Ad on page 71

## Milwaukee Rubber Products, Inc.

N 52 W 13319 Falls Creek Ct.  
Menomonee Falls, WI 53051  
800-325-3730 • 262-781-7888 • Fax: 262-781-1742  
dennis@milwaukeeerubber.com  
www.milwaukeeerubber.com  
Ad on page 147

## Mr. Manhole

1779 Canal St.  
Delphos, OH 45833  
419-741-9075 • Fax: 419-692-1600  
sales@mrrmanhole.com  
www.mrrmanhole.com  
Ad on page 55



**MTech**

7401 First Place  
Cleveland, OH 44146  
800-362-0240 • 440-646-0996 • Fax: 440-646-9953  
sales@mtechcompany.com  
www.mtechcompany.com

Ad on page 146

**Mueller Co.**

633 Chestnut St., Ste. 1200  
Chattanooga, TN 37450  
800-423-1323 • 423-209-4800 • Fax: 423-209-4850  
moreinfo@muellercompany.com  
www.muellercompany.com

**MyTana Mfg. Company, Inc.**

746 Selby Ave.  
St. Paul, MN 55104  
800-328-8170 • 651-222-1738 • Fax: 651-222-1739  
mytana@mytana.com  
www.mytana.com

Ad on page 12

**N**

**NCFI Polyurethanes**

PO Box 1528  
Mount Airy, NC 27030  
866-678-5283 • 336-789-9161 • Fax: 336-789-9586  
www.ncfi.com

Ad on page 129

**Neopoxy International, Inc.**

23964 Clawiter Road  
Hayward, CA 94545  
510-782-1290 • Fax: 510-782-1292  
epoxy@neopoxy.us  
www.neopoxy.us

Ad on page 146

**NLB Corp.**

29830 Beck Rd.  
Wixom, MI 48393  
800-227-7652 • 248-624-5555  
nlbmtg@nlbusa.com  
www.nlbcorp.com



**NozzTeg, Inc.**  
1949 Calumet St.  
Clearwater, FL 33765  
866-620-5915 • 727-223-4979 • Fax: 603-413-6744  
info@nozzteg.com  
www.nozzteg.com  
Ad on page 105

**P**

**Park Process**

7015 Fairbanks N Houston Rd.  
Houston, TX 77040-4200  
855-511-7275 • 713-937-7602 • Fax: 713-937-4254  
rcaughman@parkprocess.com  
www.park-usa.com

Ad on page 144

**Parson Environmental Products, Inc.**

PO Box 4474  
Reading, PA 19606  
800-356-9023 • 610-582-6060 • Fax: 610-582-6064  
info@parsonenvironmental.com  
www.parsonenvironmental.com

Ad on page 109

**PCI Manufacturing Solutions**

906 N Hillcrest Dr.  
Sulphur Springs, TX 75482  
800-256-5633 • 903-439-6999 • Fax: 903-885-7070  
marketing@pcimfgsolutions.com  
www.pcimfgsolutions.com



**Perma-Liner Industries, LLC**  
13000 Automobile Blvd., Ste. 300  
Clearwater, FL 33762  
866-336-2568 • 727-507-9749 • Fax: 727-507-9849  
info@perma-liner.com  
www.perma-liner.com  
Ad on page 5

**Petersen Products Co.**

PO Box 340  
Fredonia, WI 53021  
800-926-1926 • 262-692-2416 • Fax: 262-692-2418  
sales@petersenproducts.com  
www.petersenproducts.com

Ad on page 113

**Pipeline Renewal Technologies**

111-B3 Canfield Ave.  
Randolph, NJ 07869  
866-936-8476 • 973-252-6700 • Fax: 973-252-1176  
mail@pipelinert.com  
www.pipelinert.com

Ad on page 37

# Wastewater Treatment and Sludge Management Solutions from Komline-Sanderson



## Pump. Thicken. Dewater. Dry.

**Paddle Dryer**

- indirectly heated
- produce Class A product
- high efficiency



**Belt Filter Press**

- sludge dewatering
- high cake solids
- low polymer cost

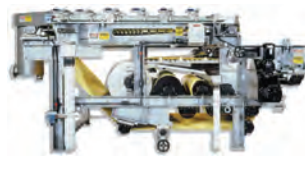

**Gravity Belt Thickener**

- sludge thickening
- high rates
- low polymer cost



**Dissolved Air Flotation**

- sludge thickening
- wastewater clarification
- high float solids



**Rotary Vacuum Filter**

- sludge dewatering
- wastewater clarification
- continuous operation



**Plunger Pump**

- sludge transfer
- positive displacement
- high suction lift





**PipeLogix, Inc.**

PO Box 14014  
Palm Desert, CA 92255  
866-299-3150 • 760-779-1700 • Fax: 760-406-6023  
joan.stone@pipelogix.com  
www.pipelogix.com  
**Ad on page 117**

**PipeTech Software**

555 Ada Dr., SE  
Ada, MI 49301  
800-262-7817 • 616-676-9811 • Fax: 616-676-9818  
sales@pipetech.tv  
www.pipetech.tv

**PK Safety**

1829 Clement Ave., Ste. 200  
Alameda, CA 94501  
800-829-9580  
pks-store@pksafety.com  
www.pksafety.com  
**Ad on page 148**

**Plasticworks, Div of Lewis Plastics**

712 W Winthrop Ave.  
Addison, IL 60101  
630-543-1750 • Fax: 630-543-4611  
chuck@plasticworks.com  
www.plasticworks.com  
**Ad on page 144**

**Pollardwater**

200 Atlantic Ave.  
New Hyde Park, NY 11040  
800-437-1146 • Fax: 516-746-0852  
info@pollardwater.com  
www.pollardwater.com

**Pow-r Mole Sales LLC**

1400 Commerce Pkwy.  
Lancaster, NY 14086  
800-344-6653 • 716-683-2486 • Fax: 716-683-6372  
brian@powrmole.com  
www.powrmole.com

**Premier**

**Premier**  
2550 E Bijou Ave.  
Fort Morgan, CO 80701  
970-542-1975  
sales@poequip.com  
www.poequipment.com

**Prime Resins**

2291 Plunkett Rd.  
Conyers, GA 30012  
800-321-7212 • 770-388-0626 • Fax: 770-388-0936  
info@primeresins.com  
www.primeresins.com  
**Ad on page 144**

**PRIMEX**

PO Box 1708  
Detroit Lakes, MN 56501  
888-342-5753 • 218-847-1317 • Fax: 218-847-4617  
info@primexcontrols.com  
www.primexcontrols.com  
**Ad on page 56**

**PROBIOSPHERE Inc.**

100 A Louis-Philippe Lebrun  
Rivière-Du-Loup, QC G5R 4K5  
Canada  
844-664-0654 • 418-868-5886 • Fax: 418-867-1782  
info@probiosphere.technology  
www.probiosphere.technology

**Proco Products, Inc.**

2431 Wigwam Dr.  
Stockton, CA 95205  
800-344-3246 • 209-943-6088 • Fax: 209-943-0242  
sales@procoproducts.com  
www.procoproducts.com  
**Ad on page 103**

**ProComSol, Ltd**

13001 Athens Ave., Ste. 220  
Lakewood, OH 44107  
877-221-1551 • 216-221-1550 • Fax: 216-221-1554  
sales@procomsol.com  
www.procomsol.com  
**Ad on page 101**

**Pronal-USA, Inc.**

3000 Opportunity Ct., Ste. A  
South Daytona, FL 32119  
386-310-1558 • Fax: 386-310-1559  
tsimuna@pronal-usa.com  
www.pronal-usa.com  
**Ad on page 113**

**R****R.S. Technical Services Inc.**

1327 Clegg St.  
Petaluma, CA 94954  
800-767-1974 • 707-778-1974 • Fax: 707-778-1981  
sales.info@rstechserv.com  
www.rstechserv.com  
**Ad on page 31**

**RapidView IBAK North America**

1828 W Olson Rd.  
Rochester, IN 46975  
800-656-4225 • 574-224-5426 • Fax: 574-223-7953  
info@rapidview.com  
www.rapidview.com  
**Ad on page 131**

**Ratech Electronics, Ltd.**

260-7 Spinnaker Way  
Concord, ON L4K 4P9  
Canada  
800-461-9200 • 905-660-7072 • Fax: 905-660-1519  
sales@ratech-electronics.com  
www.ratech-electronics.com

**Rausch USA**

4757 Innovation Way  
Chambersburg, PA 17201  
877-728-7241 • 717-709-1005 • Fax: 717-709-1009  
reusa@rauschusa.com  
www.rauschusa.com

**Red Valve Co. / Tideflex Technologies**

600 N Bell Ave.  
Carnegie, PA 15106-4322  
412-279-0044 • Fax: 412-279-7878  
sales@redvalve.com  
www.redvalve.com  
**Ad on page 19**

**Reed Manufacturing Co.**

1425 W. 8th Street  
Erie, PA 16502  
800-666-3691 • 814-452-3691 • Fax: 814-455-1697  
reedsales@reedmfgco.com  
www.reedmfgco.com  
**Ad on page 99**

**Reelcraft Industries**

2842 E Business Hwy. 30  
Columbia City, IN 46725  
800-444-3134 • 260-248-8188 • Fax: 260-248-2605  
reelcraft@reelcraft.com  
www.reelcraft.com  
**Ad on page 145**

**Reline America, Inc.**

116 Battleground Ave.  
Saltville, VA 24370  
276-496-4000 • Fax: 276-496-4870  
info@relineamerica.com  
www.relineamerica.com  
**Ad on page 11**

**RELINER/Duran Inc.**

53 Mt. Archer Rd.  
Lyme, CT 06371  
800-508-6001 • 860-434-0277 • Fax: 860-434-3195  
duran@reliner.com  
www.reliner.com  
**Ad on page 38**

**Rental Tools Online**

45969 Nokes Blvd., Ste. 120  
Sterling, VA 20166  
866-952-8665 • Fax: 866-682-1525  
info@nationaltoolleasing.com  
www.RentalToolsOnline.com  
**Ad on page 32**

**Resource West**

326 Main St., Ste. 230  
Grand Junction, CO 81501  
866-956-9378 • 970-245-7104 • Fax: 970-241-9942  
info@resourcewest.net  
www.resourcewest.net

**RIDGID**

400 Clark St.  
Elyria, OH 44035  
800-769-7743 • 440-323-5581 • Fax: 440-329-4862  
RIDGIDinfo@emerson.com  
www.RIDGID.com

**Ring-O-Matic, Inc.**

1714 Fifield Rd.  
Pella, IA 50219  
800-544-2518 • 641-628-1515  
jzylstra@ring-o-matic.com  
www.ring-o-matic.com

**RKI Instruments, Inc.**

33248 Central Ave.  
Union City, CA 94587  
800-754-5165 • 510-441-5656  
orders@rkiinstruments.com  
www.rkiinstruments.com

**Root Rat**

PO Box 740  
Bolivar, OH 44612  
800-288-7873 • 330-874-4300 • Fax: 330-874-4448  
chempure@gmail.com  
www.rootrat.net  
**Ad on page 111**

**RootX**

PO Box 7626  
Salem, OR 97303  
800-844-4974 • 503-364-2999 • Fax: 503-485-5229  
rootx@rootx.com  
www.rootx.com  
**Ad on page 39**

**S****SAERTEX-multiCom**

12200 Mt. Holly-Huntersville Rd.  
Huntersville, NC 28078  
317-464-9717 • Fax: 704-464-5922  
m.hallett@saertex.com  
www.saertex-multiCom.com  
**Ad on page 75**

**Safe-Tee Chemical Company**

16585 N 92nd St., Ste. 110  
Scottsdale, AZ 85260  
866-366-0587 • 480-968-6828 • Fax: 480-968-6776  
service@safetechemical.com  
www.safetechemical.com  
**Ad on page 145**

**Sauereisen, Inc.**

160 Gamma Dr.  
Pittsburgh, PA 15238  
800-444-8235 • 412-963-0303 • Fax: 412-963-7620  
jedavis@sauereisen.com  
www.sauereisen.com  
**Ad on page 38**

**Sealing Systems, Inc.**

9350 Cty. Rd. 19  
Loretto, MN 55357  
800-478-2054 • 763-478-2057 • Fax: 763-478-8868  
pam@ssisealingsystems.com  
www.ssisealingsystems.com  
**Ad on page 101**

**Sewer Equipment**

1590 Dutch Rd.  
Dixon, IL 61021  
888-477-7611  
sales@sewerequipment.com  
www.sewerequipment.com  
**Ad on page 149**



**Sewer Equipment Co. of Florida, Inc.**  
 1102 N Dixie Frwy.  
 New Smyrna Beach, FL 32168  
 800-635-2323 • 386-428-3303 • Fax: 386-427-4552  
 csewerequipment@cfl.rr.com  
 www.sewerequipmentco.com  
**Ad on page 147**

**Sewer Shield Composite LLC**  
 4702 E Virginia St.  
 Mesa, AZ 85215  
 480-830-9537 • Fax: 480-380-4461  
 info@sewershieldcomposites.com  
 www.sewershieldcomposites.com

**Sierra Instruments, Inc.**  
 5 Harris Ct., Bldg. L  
 Monterey, CA 93940  
 800-866-0200 • 831-373-0200 • Fax: 831-373-4402  
 info@sierrainstruments.com  
 www.sierrainstruments.com

**Simple Solutions Distributing LLC**  
 6 Jacobs Rd.  
 West Milford, NJ 07480  
 866-667-8465 • 973-846-7817 • Fax: 973-858-0219  
 sales@industrialodorcontrol.com  
 www.IndustrialOdorControl.com  
**Ad on page 145**

**SIMPSON**  
**Strong-Tie**  
**Simpson Strong-Tie Company, Inc.**  
 5956 W Las Positas Blvd.  
 Pleasanton, CA 94588  
 800-925-5099 • Fax: 925-847-1603  
 web@strongtie.com  
 www.strongtie.com  
**Ad on page 7**

**Singer Valve Inc.**  
 12850 87 Ave.  
 Surrey, BC V3W 3H9  
 Canada  
 888-764-7858 • 604-594-5404 • Fax: 604-594-8845  
 singer@singervalve.com  
 www.singervalve.com

**Smith & Loveless, Inc.**  
 14040 Santa Fe Trail Dr.  
 Lenexa, KS 66215  
 800-898-9122 • 913-888-5201  
 answers@smithandloveless.com  
 www.smithandloveless.com

**Soil Surgeon, Inc.**  
 25462 Fallen Oak  
 Laguna Niguel, CA 92677  
 949-363-1401 • Fax: 714-434-9998  
 bbain@calhaz.com  
 www.soilsurgeoninc.com

**Sonetics**  
 Sonetics  
 7340 SW Durham Rd.  
 Portland, OR 97224  
 877-959-9189 • 503-684-7080  
 sales@soneticscorp.com  
 www.soneticscorp.com/public-works



**Source One Environmental**  
 422 W Rising St.  
 Davison, MI 48423  
 877-450-3701  
 info@s1eonline.com  
 www.s1eonline.com

**Southland Tool Mfg. Inc.**  
 1430 N Hundley St.  
 Anaheim, CA 92806  
 714-632-8198 • Fax: 714-632-8228  
 sales@southlandtool.com  
 www.southlandtool.com  
**Ad on page 47**

  
**SPARTAN**  
 SPARTAN TOOL  
 1506 W Division St.  
 Mendota, IL 61342  
 800-435-3866  
 customerservice@spartantool.com  
 www.spartantool.com  
**Ad on page 21**

**Specialty Maintenance Products, Inc.**  
 5711 Clarewood, #B  
 Houston, TX 77081  
 713-667-4402 • Fax: 713-669-8618  
 sales@smptools.com  
 www.smptools.com  
**Ad on page 89**

**Sto-Away Power Cranes, Inc.**  
 9306 Grand Blvd.  
 Crown Point, IN 46307  
 800-622-9797 • 219-942-9797 • Fax: 219-947-2503  
 stoaway@comcast.net  
 www.stoaway.com  
**Ad on page 109**



**AP/M PERMAFORM**  
 The trenchless solutions company



**Providing Trenchless Solutions Through Our Network Of Certified Applicators Since 1975.**

**Visit us at WEF Collection Systems 2016, May 1-4 in Atlanta! Territories available for qualified applicators**

**Centrifugally cast storm and sewer pipe rehabilitation**



**Centrifugally cast manhole rehabilitation**



**weftec 2016**  
 Booth 1334

**www.permaform.net • 800-662-6465 • www.centripipe.com**



**SubSurface Instruments, Inc.**

1230 Flight-Way Drive  
De Pere, WI 54115  
855-422-6346 • 920-347-1788 • Fax: 920-347-1791  
paul.renard@ssilocators.com  
www.ssilocators.com

**Ad on page 144**

**SubSurface Locators, Inc.**

PO Box 5490  
Incline Village, NV 89450  
775-298-2701 • Fax: 775-298-2703  
sldi@mindspring.com  
www.subsurfaceleak.com

**Ad on page 24**

**Sunbelt Rentals**

2341 Deerfield Dr.  
Fort Mill, SC 29715  
800-736-2504  
www.sunbeltrentals.com

**Ad on page 139**

**Super Products LLC**

17000 W Cleveland Ave.  
New Berlin, WI 53151  
800-837-9711 • 262-784-710  
info@superproductslc.com  
www.superproductslc.com

**Ad on page 25**

**Superior Signal Company LLC**

PO Box 96  
Spotswood, NJ 08884  
800-945-8378 • 732-251-0800 • Fax: 732-251-9442  
info@superiorsignal.com  
www.superiorsignal.com/msw

**Ad on page 145**

**T**

**T&T Tools, Inc.**

PO Box 531  
Spring Lake, MI 49456  
800-521-6893 • Fax: 800-521-3260  
sales@mightyprobe.com  
www.mightyprobe.com

**Ad on page 103**

**Tech Products, Inc.**

105 Willow Ave.  
Staten Island, NY 10305  
800-221-1311 • 718-442-4900 • Fax: 718-442-2124  
thomas@techproducts.com  
www.techproducts.com

**The Man Pan**

309 Buffalo Ridge Rd.  
McMurray, PA 15317  
724-942-9500 • Fax: 724-942-7591  
johnmanning@themanpan.com  
www.themanpan.com

**The Plug Hug**

PO Box 386  
Bellville, OH 44813  
719-313-2791 • Fax: 419-525-2386  
douglasmarshall@theplughug.com  
www.theplughug.com

**Ad on page 145**

**The Strong Company, Inc.**

4505 Emmett Sanders Rd.  
Pine Bluff, AR 71601  
870-535-7617  
info@strongseal.com  
www.strongseal.com

**Ad on page 43**

**Thompson Pipe Group**

3011 N Laurel Ave.  
Rialto, CA 92377  
909-822-0200  
info@thompsonpipegroup.com  
www.thompsonpipegroup.com

**Ad on page 46**

**Total Piping Solutions, Inc.**

PO Box 525  
Olean, NY 14760  
716-372-0160 • Fax: 716-372-1767  
sales@tps.us  
www.tps.us

**Ad on page 93**

**Trelleborg Pipe Seals Milford, Inc.**

250 Elm St.  
Milford, NH 03055  
800-626-2180 • 603-673-8680 • Fax: 603-673-7271  
simon.burke@trelleborg.com  
www.trelleborg.com/pipe-seals

**Ad on page 144**

**TRIC Tools, Inc.**

1350 South Loop Rd., Ste. 104  
Alameda, CA 94502  
888-883-8742 • 510-629-4167 • Fax: 510-217-9493  
john.rafferty@trictools.com  
www.trictools.com

**Trio Vision LLC dba Cobra Tech**

4806 Wright Dr.  
Smyrna, GA 30082  
800-443-3761 • 770-435-8991 • Fax: 770-435-0402  
tomschmandt@cobratec.com  
www.cobratec.com

**Ad on page 27**

**Triple R Specialty**

6925 W Beaver St.  
Jacksonville, FL 32254  
800-356-9661 • Fax: 904-786-0911  
sales@triplerspecialty.com  
www.triplerspecialty.com

**Trumbull Industries, Inc.**

1040 N Meridian Rd.  
Youngstown, OH 44501  
800-677-1799 • 330-799-3333 • Fax: 330-392-0756  
info-mfg@trumbull.com  
www.trumbull-mfg.com

**Ad on page 12**

**TRY TEK Machine Works Inc.**

250 N Main St.  
Jacobus, PA 17407  
717-428-1477 • Fax: 717-428-2865  
trytek@trytek.com  
www.trytek.com

**TST Sweden AB**

Prastgatan 12  
SE-511 54 Kinna  
Sweden  
4-632-020-5880  
info@tst-sweden.com  
www.tst-sweden.com

**TURBO FOG****Division of Kingscote Chemicals**

3334 S Tech Blvd.  
Miamisburg, OH 45342  
800-394-0678 • 937-886-9100 • Fax: 937-886-9300  
sales@kingscotechemicals.com  
www.turbo-fog.com

**Ad on page 148**

**U**

**Ultra Shore**

4745 Bakers Ferry Rd. SW  
Atlanta, GA 30336  
800-746-7464 • 404-505-0510 • Fax: 404-505-0506  
info@shoring.com  
www.shoring.com

**Ad on page 99**

**USB - Sewer Equipment Corporation**

1700 Enterprise Way, Ste. 116  
Marietta, GA 30067  
866-408-2814 • 770-984-8880 • Fax: 770-984-2802  
info@usbsec.com  
www.usbsec.com

**Ad on page 69**

**V**

**Vac-Con, Inc.**

969 Hall Park Rd.  
Green Cove Springs, FL 32043  
904-284-4200 • Fax: 904-284-3305  
vns@vac-con.com  
www.vac-con.com

**Ad on page 156**

**Vac-Tron Equipment**

27317 S Hwy. 33  
Okahumpka, FL 34762  
352-728-2222  
kevin@vactron.com  
www.vactron.com

**Vacall - Gradall Industries**

406 Mill Ave. SW  
New Philadelphia, OH 44663  
800-382-8302 • 330-339-2211 • Fax: 330-339-8468  
mnorman@gradall.com  
www.vacall.com

**Ad on page 33**

**Vector Manufacturing**

1621 S Illinois St.  
Streator, IL 61364  
800-627-3171 • 815-672-3171 • Fax: 815-672-2779  
sales@vactor.com  
www.vactor.com

**Ad on page 3**

**Vacuum Sales, Inc.**

51 Stone Rd.  
Lindenwold, NJ 08021  
800-547-7790 • 856-627-7790 • Fax: 856-627-3044  
sales@vacuumsalesinc.com  
www.vacuumsalesinc.com

**Vanair Manufacturing**

10896 W 300 N  
Michigan City, IN 46360  
800-526-8817 • 219-879-5100 • Fax: 219-879-5800  
marketing@vanair.com  
www.vanair.com

**Vaporooter**

1550 E Old 210 Hwy.  
Liberty, MO 64068  
800-223-3684 • 816-781-4250 • Fax: 816-781-1043  
info@douglasproducts.com  
www.vaporooter.com

**Ad on page 137**

**VARCo**

7489 Mason King Ct.  
Manassas, VA 20109  
866-872-1224 • 703-334-5980 • Fax: 703-334-5979  
ron@varcopumper.com  
www.varcopumper.com



**Vaughan Company, Inc.**

364 Monte-Elma Rd.  
Montesano, WA 98563  
888-249-2467 • 360-249-4042 • Fax: 360-249-6155  
info@chopperpumps.com  
www.chopperpumps.com  
**Ad on page 73**

**VEGA Americas, Inc.**

4170 Rosslyn Dr.  
Cincinnati, OH 45209  
800-367-5383 • 513-272-0131 • Fax: 513-272-0133  
americas@vega.com  
www.vega.com  
**Ad on page 141**

**Venco Venturo Industries LLC**

12110 Best Place  
Cincinnati, OH 45241  
800-226-2238 • 513-772-8448 • Fax: 513-326-5427  
info@venturo.com  
www.venturo.com  
**Ad on page 105**

**Veriflo Pump Company**

7807 Redsky Dr.  
Cincinnati, OH 45249  
513-530-0888 • Fax: 513-530-0893  
sales@veriflopump.com  
www.veriflopump.com  
**Ad on page 145**



**Vivax-Metrotech Corp.**

3251 Olcott St.  
Santa Clara, CA 95054  
800-446-3392 • 408-734-1400  
info@vxmt.com  
www.vivax-metrotech.com  
**Ad on page 154**



**Water Cannon, Inc. - MWBE**

4300 West Lake Mary Blvd., Units 1010-424  
Lake Mary, FL 32746  
800-333-9274 • 321-800-5763 • Fax: 888-928-9274  
sales@watercannon.com  
www.watercannon.com/catalogrequest.aspx  
**Ads on pages 119, 145**



**WESROC by Independent Technologies, Inc.**

1960 Ridgeview Rd.  
Blair, NE 68008  
866-493-7762 • 402-426-3700 • Fax: 402-426-3705  
tomd@itcmil.net  
www.wesroc.net  
**Ad on page 146**

**WesTech Engineering**

3665 S West Temple  
Salt Lake City, UT 84115  
801-265-1000 • Fax: 801-265-1080  
info@westech-inc.com  
www.westech-inc.com

**Whirlygig, Inc.**

2418 Bishop Circle  
Caldwell, ID 83605  
800-307-4263 • Fax: 208-454-2093  
info@wgig.us  
www.wgig.us

**WinCan, LLC**

300 Cedar Ridge Dr., Ste. 308  
Pittsburgh, PA 15205  
877-626-8386 • 412-489-6229  
sales.us@wincan.com  
www.wincan.com  
**Ad on page 91**

**WL Plastics Corp.**

3575 Lone Star Circle, Ste. 400  
Fort Worth, TX 76177  
682-831-2700 • Fax: 682-831-2710  
wlsales@wlplastics.com  
www.wlplastics.com



**Xceed Machine Works Inc.**

#300, 5715-76 Ave.  
Edmonton, AB T6B 0A7  
Canada  
587-521-7544 • Fax: 587-521-8656  
forrester@xceedmachine.ca  
www.xceedmachine.ca  
**Ad on page 20**



**Zoeller Company**

3649 Cane Run Rd.  
Louisville, KY 40211  
800-928-7867 • 502-778-2731  
www.zoeller.com



*High Performance* **SEWER CLEANING EQUIPMENT**

**USB - SEC**

Your **JETTER** comes to **LIFE** with our **UNRIVALED EQUIPMENT!**

USB-SEWER EQUIPMENT CORPORATION proudly distributes INNOVATIVE, HIGH QUALITY sewer cleaning equipment, precision engineered and manufactured by our ISO EN 9001:2000 certified affiliated company USB Duesen in Germany to the highest technical standards. These products are leaders in the industry and include **NOZZLES, TURBO CHAIN CUTTERS, MILLING CUTTERS, SPECIALTY TOOLS** and **ACCESSORIES** for the municipal and industrial markets.

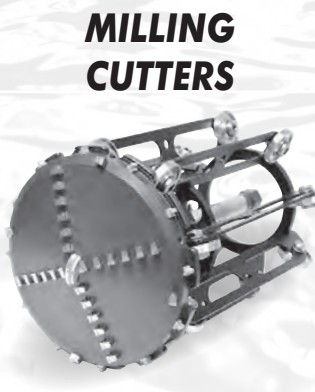
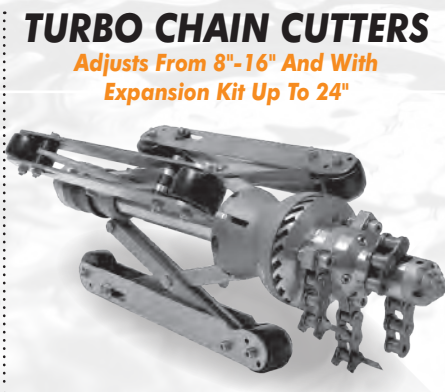
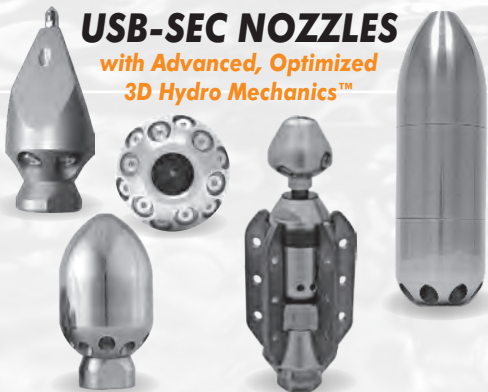

FOR A DISTRIBUTOR NEAR YOU, PLEASE CONTACT:

**USB-Sewer Equipment Corporation**

1700 Enterprise Way • Suite 116 • Marietta, GA 30067 • TOLL FREE **1.866.408.2814**

**USB - SEC** PHONE **770.984.8880** • FAX **770.984.2802** • EMAIL **info@usbsec.com** • WEB **www.usbsec.com**





## » Category Listings

### Advanced Metering Infrastructure (AMI)

#### Ferguson Waterworks

Newport News, VA  
757-874-7795  
bryan.mokry@ferguson.com  
www.ferguson.com/waterworks

Ad on page 49

### Aeration Equipment/Systems

#### American Pleasure Products, Inc.

Rose City, MI  
989-685-2697 • Fax: 989-685-8484  
info@aquacycleusa.com  
www.aquacycleusa.com

Ad on page 111

### Alarm Systems/Components

#### Data Flow Systems, Inc.

Melbourne, FL  
321-259-5009 • Fax: 321-259-4006  
www.dataflowsys.com

Ad on page 147

#### FlowWorks Inc.

Seattle, WA  
206-859-6999 • Fax: 206-320-9939  
sales@flowworks.com  
www.flowworks.com



#### Liberty Pumps

Bergen, NY  
800-543-2550 • 585-494-1817 • Fax: 585-494-1839  
laurie.pfaff@libertypumps.com  
www.libertypumps.com

#### PK Safety

Alameda, CA  
800-829-9580  
pks-store@pksafety.com  
www.pksafety.com

Ad on page 148

#### PRIMEX

Detroit Lakes, MN  
888-342-5753 • 218-847-1317 • Fax: 218-847-4617  
info@primexcontrols.com  
www.primexcontrols.com

Ad on page 56

#### Zoeller Company

Louisville, KY  
800-928-7867 • 502-778-2731  
www.zoeller.com

### Asset Management

#### Aqua Operations, Inc.

Bakersfield, CA  
888-746-6535 • 661-331-1181 • Fax: 661-833-1861  
operator@aquaooperations.com  
www.aquaooperations.com

Ad on page 146

#### Data Flow Systems, Inc.

Melbourne, FL  
321-259-5009 • Fax: 321-259-4006  
www.dataflowsys.com

Ad on page 147

#### Famhost

Wichita, KS  
800-658-1676 • 316-267-9910 • Fax: 800-858-2397  
info@famhostapps.com  
www.famhost.com

Ad on page 56

#### InfoSense, Inc.

Charlotte, NC  
877-941-3245 • 704-644-1164 • Fax: 704-930-0145  
achurchill@infosenseinc.com  
www.infosenseinc.com

Ad on page 95

#### JD7 Technologies

San Diego, CA  
858-242-1640 • Fax: 858-242-1655  
info@jd7usa.com  
www.jd7usa.com

#### Light Ring Inc.

McCallsburg, IA  
877-941-2833 • 515-290-8295 • Fax: 515-434-2249  
shane@lightringinc.com  
www.lightringinc.com

Ad on page 148



#### ProComSol, Ltd

Lakewood, OH  
877-221-1551 • 216-221-1550 • Fax: 216-221-1554  
sales@procomsol.com  
www.procomsol.com

Ad on page 101

#### WinCan, LLC

Pittsburgh, PA  
877-626-8386 • 412-489-6229  
sales.us@wincan.com  
www.wincan.com

Ad on page 91

### Association

#### PK Safety

Alameda, CA  
800-829-9580  
pks-store@pksafety.com  
www.pksafety.com

Ad on page 148

### Automatic Meter Reading (AMR)

#### Ferguson Waterworks

Newport News, VA  
757-874-7795  
bryan.mokry@ferguson.com  
www.ferguson.com/waterworks

Ad on page 49

### Bacteria/Chemicals - Grease

#### Bionetix International

Ste-Anne-de-Belleuve, QC  
Canada  
514-457-2914 • Fax: 514-457-3589  
info@bionetix.ca  
www.bionetix-international.com

#### Chempace Corporation

Toledo, OH  
800-423-5350 • 419-535-0101 • Fax: 419-535-0531  
vhorvath@chempace.com  
www.chempace.com

Ad on page 46

#### Helix Laboratories, Inc.

Corpus Christi, TX  
877-444-3549  
info@helixlabs.com  
www.helixlabs.com

Ad on page 63

#### Pollardwater

New Hyde Park, NY  
800-437-1146 • Fax: 516-746-0852  
info@pollardwater.com  
www.pollardwater.com



#### RootX

Salem, OR  
800-844-4974 • 503-364-2999 • Fax: 503-485-5229  
rootx@rootx.com  
www.rootx.com

Ad on page 39

#### Safe-Tee Chemical Company

Scottsdale, AZ  
866-366-0587 • 480-968-6828 • Fax: 480-968-6776  
service@safetechemical.com  
www.safetechemical.com

Ad on page 145

#### Simple Solutions Distributing LLC

West Milford, NJ  
866-667-8465 • 973-846-7817 • Fax: 973-858-0219  
sales@industrialodorcontrol.com  
www.IndustrialOdorControl.com

Ad on page 145



#### Vaporooter

Liberty, MO  
800-223-3684 • 816-781-4250 • Fax: 816-781-1043  
info@douglasproducts.com  
www.vaporooter.com

Ad on page 137

### Bacteria/Chemicals - Septic

#### Bionetix International

Ste-Anne-de-Belleuve, QC  
Canada  
514-457-2914 • Fax: 514-457-3589  
info@bionetix.ca  
www.bionetix-international.com

#### Chempace Corporation

Toledo, OH  
800-423-5350 • 419-535-0101 • Fax: 419-535-0531  
vhorvath@chempace.com  
www.chempace.com

Ad on page 46



#### PROBIOSPHERE Inc.

Rivière-Du-Loup, QC  
Canada  
844-664-0654 • 418-868-5886 • Fax: 418-867-1782  
info@probiosphere.technology  
www.probiosphere.technology

#### Simple Solutions Distributing LLC

West Milford, NJ  
866-667-8465 • 973-846-7817 • Fax: 973-858-0219  
sales@industrialodorcontrol.com  
www.IndustrialOdorControl.com

Ad on page 145

### Bacteria/Chemicals - Wastewater

#### Bionetix International

Ste-Anne-de-Belleuve, QC  
Canada  
514-457-2914 • Fax: 514-457-3589  
info@bionetix.ca  
www.bionetix-international.com

#### Chempace Corporation

Toledo, OH  
800-423-5350 • 419-535-0101 • Fax: 419-535-0531  
vhorvath@chempace.com  
www.chempace.com

Ad on page 46

#### Helix Laboratories, Inc.

Corpus Christi, TX  
877-444-3549  
info@helixlabs.com  
www.helixlabs.com

Ad on page 63

#### Pollardwater

New Hyde Park, NY  
800-437-1146 • Fax: 516-746-0852  
info@pollardwater.com  
www.pollardwater.com





**PROBIOSPHERE Inc.**  
Rivière-Du-Loup, QC  
Canada  
844-664-0654 • 418-868-5886 • Fax: 418-867-1782  
info@probiosphere.technology  
www.probiosphere.technology



**Vaporooter**  
Liberty, MO  
800-223-3684 • 816-781-4250 • Fax: 816-781-1043  
info@douglasproducts.com  
www.vaporooter.com  
**Ad on page 137**

## Box Culverts

**Cretex Specialty Products**  
Waukesha, WI  
800-345-3764 • 262-542-8153 • Fax: 262-542-0301  
info@cretexseals.com  
www.cretexseals.com  
**Ad on page 24**

**PCI Manufacturing Solutions**  
Sulphur Springs, TX  
800-256-5633 • 903-439-6999 • Fax: 903-885-7070  
marketing@pcimfgsolutions.com  
www.pcimfgsolutions.com

**Prime Resins**  
Conyers, GA  
800-321-7212 • 770-388-0626 • Fax: 770-388-0936  
info@primeresins.com  
www.primeresins.com  
**Ad on page 144**

**Thompson Pipe Group**  
Rialto, CA  
909-822-0200  
info@thompsonpipegroup.com  
www.thompsonpipegroup.com  
**Ad on page 46**

## Bucket Machines

**Ditch Witch**  
Perry, OK  
800-654-6481 • 580-336-4402  
info@ditchwitch.com  
www.ditchwitch.com

**Sewer Equipment**  
Dixon, IL  
888-477-7611  
sales@sewerequipment.com  
www.sewerequipment.com  
**Ad on page 149**

**Southland Tool Mfg. Inc.**  
Anaheim, CA  
714-632-8198 • Fax: 714-632-8228  
sales@southlandtool.com  
www.southlandtool.com  
**Ad on page 47**

## Buildings/Structures



**Legacy Building Solutions**  
South Haven, MN  
877-259-1528 • 320-258-0500  
legacy@legacybuildingsolutions.com  
www.legacybuildingsolutions.com

## Cable Drain Cleaning Machines



**Electric Eel Mfg.**  
Springfield, OH  
800-833-1212 • 937-323-4644 • Fax: 937-323-3767  
info@electriceel.com  
www.electriceel.com  
**Ad on page 146**

**Enz USA, Inc.**  
Aurora, IL  
877-369-8721 • 630-692-7880 • Fax: 630-692-7885  
sales@enzusainc.com  
www.enzusainc.com  
**Ad on page 77**



**General Pipe Cleaners**  
McKees Rocks, PA  
800-245-6200 • 412-771-6300  
info@drainbrain.com  
www.drainbrain.com



**MyTana Mfg. Company, Inc.**  
St. Paul, MN  
800-328-8170 • 651-222-1738 • Fax: 651-222-1739  
mytana@mytana.com  
www.mytana.com  
**Ad on page 12**

**RIDGID**  
Elyria, OH  
800-769-7743 • 440-323-5581 • Fax: 440-329-4862  
RIDGIDinfo@emerson.com  
www.RIDGID.com

# DO THE JOB ONCE

WEKO-SEAL® is the industry's leading internal joint sealing system. We have 40 years of experience and over 250,000 installations without failure. WEKO-SEAL® fixes your leaking pipeline the first time, and it lasts for generations. Do the job once. Do it with WEKO-SEAL®.

Start your project at [www.weko-seal.com](http://www.weko-seal.com)



[wekoseal@millerpipeline.com](mailto:wekoseal@millerpipeline.com)







## SPARTAN

### Spartan Tool

Mendota, IL  
800-435-3866  
customerservice@spartantool.com  
www.spartantool.com  
Ad on page 21

## Cable/Cable Attachments

### Dynamic Repairs

Lodi, NJ  
973-478-0893 • Fax: 973-478-0895  
dynamiccablerepairs@yahoo.com  
www.dynamicrepairs.biz  
Ad on page 145

### General Pipe Cleaners

McKees Rocks, PA  
800-245-6200 • 412-771-6300  
info@drainbrain.com  
www.drainbrain.com

### MyTana Mfg. Company, Inc.

St. Paul, MN  
800-328-8170 • 651-222-1738 • Fax: 651-222-1739  
mytana@mytana.com  
www.mytana.com  
Ad on page 12

### RIDGID

Elyria, OH  
800-769-7743 • 440-323-5581 • Fax: 440-329-4862  
RIDGIDinfo@emerson.com  
www.RIDGID.com



### Tech Products, Inc.

Staten Island, NY  
800-221-1311 • 718-442-4900 • Fax: 718-442-2124  
thomas@techproducts.com  
www.techproducts.com

## Camera Tractor Wheels

### Advanced Infrastructure Technologies, LLC

Torrance, CA  
844-669-9537 • 310-534-4000 • Fax: 310-534-4020  
jip@advancedworld.com  
www.advancedworld.com  
Ad on page 8

## ARIES

INDUSTRIES, INC.

### Aries Industries, Inc.

Waukesha, WI  
800-234-7205 • 262-896-7205  
sales@ariesindustries.com  
www.ariesindustries.com  
Ad on page 123

### Cua Claws

Twenty-nine Palms, CA  
714-697-8697  
jerry@cuaclaws.com  
www.cuaclaws.com  
Ad on page 145

**CUES**  
Orlando, FL  
800-327-7791 • 407-849-0190 • Fax: 407-425-1569  
salesinfo@cuesinc.com  
www.cuesinc.com  
Ad on page 15

### MTEch

Cleveland, OH  
800-362-0240 • 440-646-0996 • Fax: 440-646-9953  
sales@mtechcompany.com  
www.mtechcompany.com  
Ad on page 146

### R.S. Technical Services Inc.

Petaluma, CA  
800-767-1974 • 707-778-1974 • Fax: 707-778-1981  
sales.info@rstechserv.com  
www.rstechserv.com  
Ad on page 31

### Ratech Electronics, Ltd.

Concord, ON  
Canada  
800-461-9200 • 905-660-7072 • Fax: 905-660-1519  
sales@ratech-electronics.com  
www.ratech-electronics.com

## Catch Basin Cleaners

### Cloverleaf Tool Co.

Bradenton, FL  
800-365-6583 • 941-739-0707 • Fax: 941-739-0001  
sales@cloverleaftool.com  
www.cloverleaftool.com  
Ad on page 115

### Environmental Rental Services LTD

Rockdale, TX  
512-446-7011 • Fax: 512-446-7195  
sterling@ersvacrent.com  
www.ersvacrent.com  
Ad on page 148

### Jack Doheny Companies

Northville, MI  
800-336-4369 • 248-349-0904 • Fax: 248-349-2774  
info@dohenycompanies.com  
www.dohenycompanies.com

### McLaughlin Group

Greenville, SC  
800-435-9340 • 864-277-5870 • Fax: 864-235-9661  
mmole@mightymole.com  
www.mclaughlinunderground.com

### MTEch

Cleveland, OH  
800-362-0240 • 440-646-0996 • Fax: 440-646-9953  
sales@mtechcompany.com  
www.mtechcompany.com  
Ad on page 146

### Sewer Equipment

Dixon, IL  
888-477-7611  
sales@sewerequipment.com  
www.sewerequipment.com  
Ad on page 149

### Sewer Equipment Co. of Florida, Inc.

New Smyrna Beach, FL  
800-635-2323 • 386-428-3303 • Fax: 386-427-4552  
csewerequipment@cfi.fl.com  
www.sewerequipmentco.com  
Ad on page 147

### Southland Tool Mfg. Inc.

Anaheim, CA  
714-632-8198 • Fax: 714-632-8228  
sales@southlandtool.com  
www.southlandtool.com  
Ad on page 47

### Super Products LLC

New Berlin, WI  
800-837-9711 • 262-784-710  
info@superproductsllc.com  
www.superproductsllc.com  
Ad on page 25



### Vac-Con, Inc.

Green Cove Springs, FL  
904-284-4200 • Fax: 904-284-3305  
vns@vac-con.com  
www.vac-con.com  
Ad on page 156



### Vacall - Gradall Industries

New Philadelphia, OH  
800-382-8302 • 330-339-2211 • Fax: 330-339-8468  
mitnorman@gradall.com  
www.vacall.com  
Ad on page 33

### Vector Manufacturing

Streator, IL  
800-627-3171 • 815-672-3171 • Fax: 815-672-2779  
sales@vactor.com  
www.vactor.com  
Ad on page 3

### Vacuum Sales, Inc.

Lindenwold, NJ  
800-547-7790 • 856-627-7790 • Fax: 856-627-3044  
sales@vacuumsalesinc.com  
www.vacuumsalesinc.com

## Catch Basin Filter

### Advanced Aquatic Products

International, Inc.  
Cutler Bay, FL  
800-738-7646 • 305-388-7195 • Fax: 305-388-7196  
advaquaticprods@aol.com  
www.hydro-cartridge.com  
Ad on page 107



### Advanced Drainage Systems, Inc. - ADS

Hilliard, OH  
800-773-7473  
www.ads-pipe.com

### Best Management Products, Inc.

Lyme, CT  
800-504-8008 • 410-687-6256 • Fax: 877-434-3197  
tjm@bmpinc.com  
www.bmpinc.com  
Ad on page 24

## Catch Basins



### Advanced Drainage Systems, Inc. - ADS

Hilliard, OH  
800-773-7473  
www.ads-pipe.com

### American Highway Products, Ltd.

Bolivar, OH  
888-272-2397 • 330-874-3270 • Fax: 330-874-3800  
sales@ahp1.com  
www.ahp1.com  
Ad on page 97

### CreteX Specialty Products

Waukesha, WI  
800-345-3764 • 262-542-8153 • Fax: 262-542-0301  
info@cretexseals.com  
www.cretexseals.com  
Ad on page 24

### HARCO Fittings

Lynchburg, VA  
434-845-7094 • Fax: 434-845-8562  
sales@harcofittings.com  
www.harcofittings.com  
Ad on page 148



### LADTECH, Inc.

Lino Lakes, MN  
877-235-7464 • 651-415-1252 • Fax: 651-415-1090  
adring@ladtech.com  
www.ladtech.com  
Ad on page 85

### Park Process

Houston, TX  
855-511-7275 • 713-937-7602 • Fax: 713-937-4254  
rcoughman@parkprocess.com  
www.park-usa.com  
Ad on page 144

### Root Rat

Bolivar, OH  
800-288-7873 • 330-874-4300 • Fax: 330-874-4448  
chempure@gmail.com  
www.rootrat.net  
Ad on page 111



## Chemicals - Cleaning

**Bionetix International**  
Ste-Anne-de-Bellevue, QC  
Canada  
514-457-2914 • Fax: 514-457-3589  
info@bionetix.ca  
www.bionetix-international.com

**Cortec Corporation**  
St. Paul, MN  
651-429-1100 • Fax: 651-429-1122  
info@cortecvci.com  
www.cortecvci.com

**Helix Laboratories, Inc.**  
Corpus Christi, TX  
877-444-3549  
info@helixlabs.com  
www.helixlabs.com  
**Ad on page 63**

**PK Safety**  
Alameda, CA  
800-829-9580  
pks-store@pksafety.com  
www.pksafety.com  
**Ad on page 148**

**Safe-Tee Chemical Company**  
Scottsdale, AZ  
866-366-0587 • 480-968-6828 • Fax: 480-968-6776  
service@safetechemical.com  
www.safetechemical.com  
**Ad on page 145**

**Simple Solutions Distributing LLC**  
West Milford, NJ  
866-667-8465 • 973-846-7817 • Fax: 973-858-0219  
sales@industrialodorcontrol.com  
www.IndustrialOdorControl.com  
**Ad on page 145**

## Chemicals - Dewatering

**Boerger, LLC**  
Chanhassen, MN  
612-435-7300 • Fax: 612-435-7301  
america@boerger.com  
www.boerger.com

**PK Safety**  
Alameda, CA  
800-829-9580  
pks-store@pksafety.com  
www.pksafety.com  
**Ad on page 148**

**Prime Resins**  
Conyers, GA  
800-321-7212 • 770-388-0626 • Fax: 770-388-0936  
info@primeresins.com  
www.primeresins.com  
**Ad on page 144**

## Chemicals - Wastewater Treatment

**ABS Materials, Inc.**  
Wooster, OH  
330-234-7999  
info@absmaterials.com  
www.abswastewater.com  
**Ad on page 148**

**Bionetix International**  
Ste-Anne-de-Bellevue, QC  
Canada  
514-457-2914 • Fax: 514-457-3589  
info@bionetix.ca  
www.bionetix-international.com

**Boerger, LLC**  
Chanhassen, MN  
612-435-7300 • Fax: 612-435-7301  
america@boerger.com  
www.boerger.com

**CHEMetrics, Inc.**  
Midland, VA  
800-356-3072 • 540-788-9026 • Fax: 540-788-4856  
sales@chemetrics.com  
www.chemetrics.com

**Chempace Corporation**  
Toledo, OH  
800-423-5350 • 419-535-0101 • Fax: 419-535-0531  
vhorvath@chempace.com  
www.chempace.com  
**Ad on page 46**

**PK Safety**  
Alameda, CA  
800-829-9580  
pks-store@pksafety.com  
www.pksafety.com  
**Ad on page 148**

**Simple Solutions Distributing LLC**  
West Milford, NJ  
866-667-8465 • 973-846-7817 • Fax: 973-858-0219  
sales@industrialodorcontrol.com  
www.IndustrialOdorControl.com  
**Ad on page 145**

## Chemicals - Water Treatment

**ABS Materials, Inc.**  
Wooster, OH  
330-234-7999  
info@absmaterials.com  
www.abswastewater.com  
**Ad on page 148**

**Triton**  
**EFFICIENCY  
AT EVERY TURN**  
SINCE 1960

The Triton Screw Centrifugal Pump combines the benefits of Vaughan's UNMATCHED RELIABILITY with the advantages of highly efficient, non-clog performance. Triton's screw centrifugal impeller is ideal for handling thick sludges, large solids, shear sensitive fluids and delicate or highly abrasive material.

See videos, drawings, and details at [ChopperPumps.com](http://ChopperPumps.com) or call 888.249.CHOP





**American Highway Products, Ltd.**

Bolivar, OH  
888-272-2397 • 330-874-3270 • Fax: 330-874-3800  
sales@ahp1.com  
www.ahp1.com

**Ad on page 97**

**Boerger, LLC**

Chanhassen, MN  
612-435-7300 • Fax: 612-435-7301  
america@boerger.com  
www.boerger.com

**CHEMetrics, Inc.**

Midland, VA  
800-356-3072 • 540-788-9026 • Fax: 540-788-4856  
sales@chemetrics.com  
www.chemetrics.com

**Cortec Corporation**

St. Paul, MN  
651-429-1100 • Fax: 651-429-1122  
info@cortecvci.com  
www.cortecvci.com

**Helix Laboratories, Inc.**

Corpus Christi, TX  
877-444-3549  
info@helixlabs.com  
www.helixlabs.com

**Ad on page 63**

**PK Safety**

Alameda, CA  
800-829-9580  
pks-store@pksafety.com  
www.pksafety.com

**Ad on page 148**

**CIPP****Applied Felts, Inc.**

Martinsville, VA  
276-656-1904 • Fax: 276-656-1909  
info@appliedfelts.com  
www.appliedfelts.com

**Ad on page 9**

**Aries Industries, Inc.**

Waukesha, WI  
800-234-7205 • 262-896-7205  
sales@ariesindustries.com  
www.ariesindustries.com

**Ad on page 123**

**Clean Water Works Inc.**

Ottawa, ON  
Canada  
866-695-0155 • 613-745-2444 • Fax: 613-745-9994  
kpeori@cwcanada.com  
www.cwcanada.com

**Electro Scan Inc.**

Sacramento, CA  
800-975-6149 • 916-779-0660 • Fax: 916-779-0661  
info@electroscan.com  
www.electroscan.com

**Ad on page 153**

**THE SHOOTER®****Emagineered Solutions, Inc.**

Redmond, OR  
541-504-0416 • Fax: 541-504-0417  
roy.i@emagineered.com  
www.theshooteripp.com

**Ferratex, Inc.**

McKenney, VA  
804-451-3667 • Fax: 804-478-8296  
justing@ferratex.com  
www.ferratex.com

**HammerHead Trenchless Equipment**

Lake Mills, WI  
800-331-6653 • 920-648-4848  
jhaas@hammerheadmole.com  
www.hammerheadtrenchless.com

**Ad on page 45**

**Inliner Technologies**

Paoli, IN  
812-723-0704  
info@inliner.com  
www.inliner.com

**Ad on page 23**

**Light Ring Inc.**

McCallsburg, IA  
877-941-2833 • 515-290-8295 • Fax: 515-434-2249  
shane@lightringinc.com  
www.lightringinc.com

**Ad on page 148**

**Linabond, Inc.**

Camarillo, CA  
805-484-7373  
info@linabond.com  
www.linabond.com

**LMK Technologies**

Ottawa, IL  
815-433-1275 • Fax: 815-433-0107  
info@lmktechnologies.com  
www.lmktechnologies.com

**Ad on page 143**

**Logiball, Inc.**

Quebec, QC  
Canada  
800-246-5988 • 418-656-9767 • Fax: 418-653-5746  
info@logiball.com  
www.logiball.com/en

**Miller Pipeline**

Indianapolis, IN  
800-428-3742 • 317-293-0278  
www.millerpipeline.com

**Ad on page 71**

**Perma-Liner Industries, LLC**

Clearwater, FL  
866-336-2568 • 727-507-9749 • Fax: 727-507-9849  
info@perma-liner.com  
www.perma-liner.com

**Ad on page 5**

**Reline America, Inc.**

Salville, VA  
276-496-4000 • Fax: 276-496-4870  
info@relineamerica.com  
www.relineamerica.com

**Ad on page 11**

**SAERTEX-multiCom**

Huntersville, NC  
317-464-9717 • Fax: 704-464-5922  
m.hallett@saertex.com  
www.saertex-multicom.com

**Ad on page 75**

**Source One Environmental**

Davison, MI  
877-450-3701  
info@s1eonline.com  
www.s1eonline.com

**Trelleborg Pipe Seals Milford, Inc.**

Milford, NH  
800-626-2180 • 603-673-8680 • Fax: 603-673-7271  
simon.burke@trelleborg.com  
www.trelleborg.com/pipes-seals

**Ad on page 144**

**TRY TEK Machine Works Inc.**

Jacobus, PA  
717-428-1477 • Fax: 717-428-2865  
trytek@trytek.com  
www.trytek.com

**Clothing/Workwear****PK Safety**

Alameda, CA  
800-829-9580  
pks-store@pksafety.com  
www.pksafety.com

**Ad on page 148**

**TST Sweden AB**

SE-511 54 Kinna  
Sweden  
4-632-020-5880  
info@tst-sweden.com  
www.tst-sweden.com

**Coatings/Linings/  
Sealants****AP/M Permaform**

Johnston, IA  
800-662-6465 • 515-276-9610 • Fax: 515-276-1274  
info@permaform.net  
www.permaform.net

**Ad on page 67**

**Clean Water Works Inc.**

Ottawa, ON  
Canada  
866-695-0155 • 613-745-2444 • Fax: 613-745-9994  
kpeori@cwcanada.com  
www.cwcanada.com

**Cortec Corporation**

St. Paul, MN  
651-429-1100 • Fax: 651-429-1122  
info@cortecvci.com  
www.cortecvci.com

**CreteX Specialty Products**

Waukesha, WI  
800-345-3764 • 262-542-8153 • Fax: 262-542-0301  
info@cretexseals.com  
www.cretexseals.com

**Ad on page 24**

**Environmental Coatings LLC**

Mesa, AZ  
480-984-7608 • Fax: 480-380-4461  
info@sewershield.com  
www.sewershield.com

**HydraTech Engineered Products**

Cincinnati, OH  
513-827-9169 • Fax: 513-827-9171  
info@hydrattechllc.com  
www.hydrattechllc.com

**Ad on page 145**

**Infrastructure Repair Systems Inc.**

St. Petersburg, FL  
877-327-4216 • Fax: 727-327-4118  
irsi@irsi.net  
www.irsi.net

**Ad on page 46**

**Linabond, Inc.**

Camarillo, CA  
805-484-7373  
info@linabond.com  
www.linabond.com

**Liner Products**

1468 W Hospital Rd.  
Paoli, IN 47454  
812-723-0244  
info@linerproducts.com  
www.linerproducts.com

**LMK Technologies**

Ottawa, IL  
815-433-1275 • Fax: 815-433-0107  
info@lmktechnologies.com  
www.lmktechnologies.com

**Ad on page 143**





**Miller Pipeline**

Indianapolis, IN  
800-428-3742 • 317-293-0278  
www.millerpipeline.com  
Ad on page 71

**NCFI Polyurethanes**

Mount Airy, NC  
866-678-5283 • 336-789-9161 • Fax: 336-789-9586  
www.ncfi.com  
Ad on page 129

**Neopoxy International, Inc.**

Hayward, CA  
510-782-1290 • Fax: 510-782-1292  
epoxy@neopoxy.us  
www.neopoxy.us  
Ad on page 146

**Park Process**

Houston, TX  
855-511-7275 • 713-937-7602 • Fax: 713-937-4254  
rcaughman@parkprocess.com  
www.park-usa.com  
Ad on page 144

**Parson Environmental Products, Inc.**

Reading, PA  
800-356-9023 • 610-582-6060 • Fax: 610-582-6064  
info@parsonenvironmental.com  
www.parsonenvironmental.com  
Ad on page 109

**Perma-Liner Industries, LLC**  
Clearwater, FL  
866-336-2568 • 727-507-9749 • Fax: 727-507-9849  
info@perma-liner.com  
www.perma-liner.com  
Ad on page 5

**Prime Resins**

Conyers, GA  
800-321-7212 • 770-388-0626 • Fax: 770-388-0936  
info@primeresins.com  
www.primeresins.com  
Ad on page 144

**RELINER/Duran Inc.**

Lyme, CT  
800-508-6001 • 860-434-0277 • Fax: 860-434-3195  
duran@reliner.com  
www.reliner.com  
Ad on page 38

**SAERTEX-multiCom**

Huntersville, NC  
317-464-9717 • Fax: 704-464-5922  
m.hallett@saertex.com  
www.saertex-multicom.com  
Ad on page 75

**Sealing Systems, Inc.**

Loretto, MN  
800-478-2054 • 763-478-2057 • Fax: 763-478-8868  
pam@ssisealingsystems.com  
www.ssisealingsystems.com  
Ad on page 101

**Sewer Shield Composite LLC**

Mesa, AZ  
480-830-9537 • Fax: 480-380-4461  
info@sewershieldcomposites.com  
www.sewershieldcomposites.com

**Source One Environmental**

Davison, MI  
877-450-3701  
info@s1eonline.com  
www.s1eonline.com

**Trelleborg Pipe Seals Milford, Inc.**

Milford, NH  
800-626-2180 • 603-673-8680 • Fax: 603-673-7271  
simon.burke@trelleborg.com  
www.trelleborg.com/pipe-seals  
Ad on page 144

**Communication Equipment**

**Sonetics**

Sonetics  
Portland, OR  
877-959-9189 • 503-684-7080  
sales@soneticscorp.com  
www.soneticscorp.com/public-works

**Consulting/Engineering**

**Aqua Operations, Inc.**

Bakersfield, CA  
888-746-6535 • 661-331-1181 • Fax: 661-833-1861  
operator@aquaoptions.com  
www.aquaoptions.com  
Ad on page 146

**Electro Scan Inc.**

Sacramento, CA  
800-975-6149 • 916-779-0660 • Fax: 916-779-0661  
info@electroscan.com  
www.electroscan.com  
Ad on page 153

**Endress+Hauser**

Greenwood, IN  
888-363-7377 • Fax: 317-535-8498  
info@us.endress.com  
www.us.endress.com

The UV Cured **SAERTEX-LINER®**:  
Next Generation of GRP Liners!

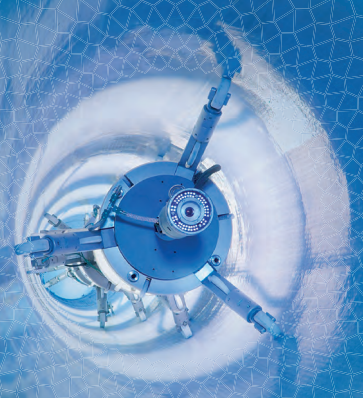

High Strength GRP Liner for Sewer, Pressure and Water Pipes

SAERTEX multiCom LP | 12200 - A Mt. Holly-Huntersville Rd. | Huntersville, NC 28078 | USA | Phone: +1 317 464-9717  
Fax: + 1 704 464 - 5922 | E-Mail: multicom@saertex.com | www.saertex-multicom.com



**HammerHead Trenchless Equipment**

Lake Mills, WI  
800-331-6653 • 920-648-4848  
jhaas@hammerheadmole.com  
www.hammerheadtrenchless.com

Ad on page 45

**HydraTech Engineered Products**

Cincinnati, OH  
513-827-9169 • Fax: 513-827-9171  
info@hydrattechllc.com  
www.hydrattechllc.com

Ad on page 145

**KEG Technologies, Inc.**

Spartanburg, SC  
866-595-0515 • 864-804-6637 • Fax: 864-804-6629  
sales@kegtechnologies.net  
www.kegtechnologies.net

Ad on page 107

**KOHLER Power Systems**

Kohler, WI  
800-544-2444 • 920-457-4441 • Fax: 920-459-1646  
generator.feedback@kohler.com  
www.kohlerpower.com

**LADTECH, Inc.**

Lino Lakes, MN  
877-235-7464 • 651-415-1252 • Fax: 651-415-1090  
adjiring@ladtech.com  
www.ladtech.com

Ad on page 85

**NozzTeq, Inc.**

Clearwater, FL  
866-620-5915 • 727-223-4979 • Fax: 603-413-6744  
info@nozzteq.com  
www.nozzteq.com

Ad on page 105

**PK Safety**

Alameda, CA  
800-829-9580  
pks-store@pksafety.com  
www.pksafety.com

Ad on page 148

**Whirlygig, Inc.**

Caldwell, ID  
800-307-4263 • Fax: 208-454-2093  
info@wgig.us  
www.wgig.us

**Corrosion Control/  
Protection****AA Thread Seal Tape, Inc.**

Wauconda, IL  
800-537-7139 • 847-526-2120 • Fax: 847-526-2209  
ryan@aathread.com  
www.aathread.com

Ad on page 148

**Cranes/Hoists/Winches****EZ Rig Crane**

Ventura, CA  
844-395-4387 • 805-643-4387 • Fax: 805-642-9925  
info@ezrigcrane.com  
www.ezrigcrane.com

**PK Safety**

Alameda, CA  
800-829-9580  
pks-store@pksafety.com  
www.pksafety.com

Ad on page 148

**Sto-Away Power Cranes, Inc.**

Crown Point, IN  
800-622-9797 • 219-942-9797 • Fax: 219-947-2503  
stoaway@comcast.net  
www.stoaway.com

Ad on page 109

**Venco Venturo Industries LLC**

Cincinnati, OH  
800-226-2238 • 513-772-8448 • Fax: 513-326-5427  
info@venturo.com  
www.venturo.com

Ad on page 105

**Data Loggers/  
Management****ADS LLC**

Huntsville, AL  
800-633-7246 • 256-430-3366 • Fax: 256-430-6633  
adssales@idexcorp.com  
www.adsenv.com

Ad on page 29

**Aqua Operations, Inc.**

Bakersfield, CA  
888-746-6535 • 661-331-1181 • Fax: 661-833-1861  
operator@aquoperations.com  
www.aquaoperations.com

Ad on page 146

**Data Flow Systems, Inc.**

Melbourne, FL  
321-259-5009 • Fax: 321-259-4006  
www.dataflowsys.com

Ad on page 147

**Endress+Hauser**

Greenwood, IN  
888-363-7377 • Fax: 317-535-8498  
info@us.endress.com  
www.us.endress.com

**FlowWorks Inc.**

Seattle, WA  
206-859-6999 • Fax: 206-320-9939  
sales@flowworks.com  
www.flowworks.com

**Hach - Flow Products & Services**

Loveland, CO  
800-368-2723  
www.hachflow.com

**Hermann Sewerin GmbH**

D-33334 Gutersloh  
Germany  
888-592-9916 • Fax: 495241934444  
sewerin-usa@sewerin.net  
www.sewerin.com

**Hurco Technologies, Inc.**

Harrisburg, SD  
800-888-1436 • 605-743-2466  
info@hurcotech.com  
www.hurcotech.com

Ad on page 20

**Matchpoint Water Asset Management, Inc.**

Wilmington, NC  
910-509-7225 • 910-509-7226  
info@matchpointinc.us  
www.matchpointinc.us

Ad on page 133

**PK Safety**

Alameda, CA  
800-829-9580  
pks-store@pksafety.com  
www.pksafety.com

Ad on page 148

**PRIMEX**

Detroit Lakes, MN  
888-342-5753 • 218-847-1317 • Fax: 218-847-4617  
info@primexcontrols.com  
www.primexcontrols.com

Ad on page 56

**Reline America, Inc.**

Saltsville, VA  
276-496-4000 • Fax: 276-496-4870  
info@relineamerica.com  
www.relineamerica.com

Ad on page 11

**Detection Equipment****Endress+Hauser**

Greenwood, IN  
888-363-7377 • Fax: 317-535-8498  
info@us.endress.com  
www.us.endress.com

**General Pipe Cleaners**

McKees Rocks, PA  
800-245-6200 • 412-771-6300  
info@drainbrain.com  
www.drainbrain.com

**Hermann Sewerin GmbH**

D-33334 Gutersloh  
Germany  
888-592-9916 • Fax: 495241934444  
sewerin-usa@sewerin.net  
www.sewerin.com

**JD7 Technologies**

San Diego, CA  
858-242-1640 • Fax: 858-242-1655  
info@jd7usa.com  
www.jd7usa.com

**Matchpoint Water Asset Management, Inc.**

Wilmington, NC  
910-509-7225 • 910-509-7226  
info@matchpointinc.us  
www.matchpointinc.us

Ad on page 133

**MyTana Mfg. Company, Inc.**

St. Paul, MN  
800-328-8170 • 651-222-1738 • Fax: 651-222-1739  
mytana@mytana.com  
www.mytana.com

Ad on page 12

**PK Safety**

Alameda, CA  
800-829-9580  
pks-store@pksafety.com  
www.pksafety.com

Ad on page 148

**RKI Instruments, Inc.**

Union City, CA  
800-754-5165 • 510-441-5656  
orders@rkiinstruments.com  
www.rkiinstruments.com

**SubSurface Instruments, Inc.**

De Pere, WI  
855-422-6346 • 920-347-1788 • Fax: 920-347-1791  
paul.renard@ssilocators.com  
www.ssilocators.com

Ad on page 144

**Triple R Specialty**

Jacksonville, FL  
800-356-9661 • Fax: 904-786-0911  
sales@triplerspecialty.com  
www.triplerspecialty.com

**Dewatering Equipment****Boerger, LLC**

Chanhassen, MN  
612-435-7300 • Fax: 612-435-7301  
america@boerger.com  
www.boerger.com

**Custom Manufacturing, Inc.**

Oklahoma City, OK  
888-692-6311 • 405-692-6311 • Fax: 405-691-8190  
jamie@custommanufacturing.us  
www.custommanufacturing.us

**Hastings Irrigation Pipe Co.**

Hastings, NE  
800-759-8823 • Fax: 402-463-4355  
giones@hipco-ne.com  
www.hastingsirrigation.com



**JWC Environmental**

Santa Ana, CA  
800-331-2277 • 949-833-3888 • Fax: 714-428-4644  
jwce@jwce.com  
www.jwce.com

Ad on page 32

**J. Hvidtved Larsen US, Inc.**

Chicago, IL  
312-705-3818  
jhl@hvidtved.com  
www.hvidtved.com

**Komline-Sanderson**

Peapack, NJ  
800-225-5457 • 908-234-1000 • Fax: 908-234-9487  
info@komline.com  
www.komline.com

Ad on page 65

**Milwaukee Rubber Products, Inc.**

Menomonee Falls, WI  
800-325-3730 • 262-781-7888 • Fax: 262-781-1742  
dennis@milwaukeeerubber.com  
www.milwaukeeerubber.com

Ad on page 147

**Red Valve Co. / Tideflex Technologies**

Carnegie, PA  
412-279-0044 • Fax: 412-279-7878  
sales@redvalve.com  
www.redvalve.com

Ad on page 19



**Resource West**

Grand Junction, CO  
866-956-9378 • 970-245-7104 • Fax: 970-241-9942  
info@resourcewest.net  
www.resourcewest.net

**Sunbelt Rentals**

Fort Mill, SC  
800-736-2504  
www.sunbeltrentals.com

Ad on page 139

**Vertiflo Pump Company**

Cincinnati, OH  
513-530-0888 • Fax: 513-530-0893  
sales@vertiflopump.com  
www.vertiflopump.com

Ad on page 145

**Westech Engineering**

Salt Lake City, UT  
801-265-1000 • Fax: 801-265-1080  
info@westech-inc.com  
www.westech-inc.com

**Zoeller Company**

Louisville, KY  
800-928-7867 • 502-778-2731  
www.zoeller.com

**Ductile Iron Pipe Accessories**

**AA Thread Seal Tape, Inc.**

Wauconda, IL  
800-537-7139 • 847-526-2120 • Fax: 847-526-2209  
ryan@aathread.com  
www.aathread.com

Ad on page 148

**Easement Machine**

**3T Equipment Company Inc.**

Santa Rosa, CA  
800-969-3001 • 707-543-8555 • Fax: 707-543-8558  
titequip@yahoo.com  
www.3tequipco.com

Ad on page 115

**Advanced Infrastructure Technologies, LLC**

Torrance, CA  
844-669-9537 • 310-534-4000 • Fax: 310-534-4020  
jp@advancedworld.com  
www.advancedworld.com

Ad on page 8

**Environmental Rental Services LTD**

Rockdale, TX  
512-446-7011 • Fax: 512-446-7195  
sterling@ersvacrent.com  
www.ersvacrent.com

Ad on page 148

**Jack Doheny Companies**

Northville, MI  
800-336-4369 • 248-349-0904 • Fax: 248-349-2774  
info@dohenycompanies.com  
www.dohenycompanies.com



**K&W Products, Inc.**

Elberta, AL  
800-503-0076 • 251-986-7900 • Fax: 251-986-7902  
sales@kwproducts.net  
www.kwmiequipment.com

Ad on page 147

**MTech**

Cleveland, OH  
800-362-0240 • 440-646-0996 • Fax: 440-646-9953  
sales@mtechcompany.com  
www.mtechcompany.com

Ad on page 146

**Sewer Equipment**

Dixon, IL  
888-477-7611  
sales@sewerequipment.com  
www.sewerequipment.com

Ad on page 149

**ROYAL FLUSH!**

**Be the Big Winner with ENZ Flushing Solutions!**

Whatever your unique flushing challenge, Enz has a nozzle designed specifically for your job. Whether you are removing mud and loose rubble in run-off drains, flushing enormous quantities of sand and gravel from surcharged older channel systems, or cleaning storm drains, culverts and pipes up to 100" in diameter, Enz has the solution for you.

*Enz stacks the deck when it comes to the most efficient flushing systems on the market!*

**POWERFUL**

**EJECTOR NOZZLE**  
Amplifies water flow 5X  
Max. Working Pressure:  
3800 psi



**VERSATILE**

**GRENADE-BOMB**  
Combines high performance & versatility  
Max. Working Pressure: 4000 psi



**DURABLE**

**FLOUNDER**  
Compact & aggressive water jet  
Max. Working Pressure: 4000 psi

**RELIABLE**

**BULLDOZER**  
Drastically reduces clean-up time & water consumption  
Max. Working Pressure: 4000 psi

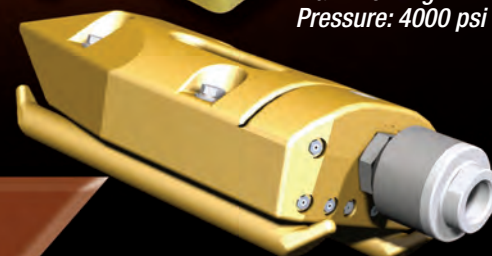

**Got a Flushing Problem? We Have the Solution—  
Call 877-ENZUSA1 (369-8721) for A Dealer Near You!**



1585 Beverly Ct., Unit 115 • Aurora, IL 60502  
www.enz.com



**Trio Vision LLC dba Cobra Tech**

Smyrna, GA  
800-443-3761 • 770-435-8991 • Fax: 770-435-0402  
tomschmandt@cobratec.com  
www.cobratec.com  
**Ad on page 27**

**Education****Aqua Operations, Inc.**

Bakersfield, CA  
888-746-6535 • 661-331-1181 • Fax: 661-833-1861  
operator@aquaoptions.com  
www.aquaoptions.com  
**Ad on page 146**

**Electro Scan Inc.**

Sacramento, CA  
800-975-6149 • 916-779-0660 • Fax: 916-779-0661  
info@electroscan.com  
www.electroscan.com  
**Ad on page 153**

**Enz USA, Inc.**

Aurora, IL  
877-369-8721 • 630-692-7880 • Fax: 630-692-7885  
sales@enzusainc.com  
www.enzusainc.com  
**Ad on page 77**

**Jack Doheny Companies**

Northville, MI  
800-336-4369 • 248-349-0904 • Fax: 248-349-2774  
info@dohenycompanies.com  
www.dohenycompanies.com

**KEG Technologies, Inc.**

Spartanburg, SC  
866-595-0515 • 864-804-6637 • Fax: 864-804-6629  
sales@kegtechnologies.net  
www.kegtechnologies.net  
**Ad on page 107**

**Epoxy Coatings****AP/M Permaform**

Johnston, IA  
800-662-6465 • 515-276-9610 • Fax: 515-276-1274  
info@permaform.net  
www.permaform.net  
**Ad on page 67**

**CCI Pipeline Systems**

Breaux Bridge, LA  
800-867-2772 • 337-332-5808 • Fax: 337-332-5809  
sales@ccipipe.com  
www.ccipipe.com

**Environmental Coatings LLC**

Mesa, AZ  
480-984-7608 • Fax: 480-380-4461  
info@sewershield.com  
www.sewershield.com

**HARCO Fittings**

Lynchburg, VA  
434-845-7094 • Fax: 434-845-8562  
sales@harcofittings.com  
www.harcofittings.com  
**Ad on page 148**

**HydraTech Engineered Products**

Cincinnati, OH  
513-827-9169 • Fax: 513-827-9171  
info@hydrattechllc.com  
www.hydrattechllc.com  
**Ad on page 145**

**Infrastructure Repair Systems Inc.**

St. Petersburg, FL  
877-327-4216 • Fax: 727-327-4118  
irsi@irsi.net  
www.irsi.net  
**Ad on page 46**

**Linabond, Inc.**

Camarillo, CA  
805-484-7373  
info@linabond.com  
www.linabond.com

**Neopoxy International, Inc.**

Hayward, CA  
510-782-1290 • Fax: 510-782-1292  
epoxy@neopoxy.us  
www.neopoxy.us  
**Ad on page 146**

**Parson Environmental Products, Inc.**

Reading, PA  
800-356-9023 • 610-582-6060 • Fax: 610-582-6064  
info@parsonenvironmental.com  
www.parsonenvironmental.com  
**Ad on page 109**

**Prime Resins**

Conyers, GA  
800-321-7212 • 770-388-0626 • Fax: 770-388-0936  
info@primeresins.com  
www.primeresins.com  
**Ad on page 144**

**Sauereisen, Inc.**

Pittsburgh, PA  
800-444-8235 • 412-963-0303 • Fax: 412-963-7620  
jedavis@sauereisen.com  
www.sauereisen.com  
**Ad on page 38**

**Simpson Strong-Tie Company, Inc.**

Pleasanton, CA  
800-925-5099 • Fax: 925-847-1603  
web@strongtie.com  
www.strongtie.com  
**Ad on page 7**

**Source One Environmental**

Davison, MI  
877-450-3701  
info@s1eonline.com  
www.s1eonline.com

**The Strong Company, Inc.**

Pine Bluff, AR  
870-535-7617  
info@strongseal.com  
www.strongseal.com  
**Ad on page 43**

**Erosion Control****Agri America, Inc.**

Georgetown, SC  
800-373-2478 • 843-546-0600 • Fax: 843-527-2738  
salesmkg@agriamerica.com  
www.agriamerica.com  
**Ad on page 55**

**Ferguson Waterworks**

Newport News, VA  
757-874-7795  
bryan.mokry@ferguson.com  
www.ferguson.com/waterworks  
**Ad on page 49**

**Prime Resins**

Conyers, GA  
800-321-7212 • 770-388-0626 • Fax: 770-388-0936  
info@primeresins.com  
www.primeresins.com  
**Ad on page 144**

**Sealing Systems, Inc.**

Loretto, MN  
800-478-2054 • 763-478-2057 • Fax: 763-478-8868  
pam@ssisealingsystems.com  
www.ssisealingsystems.com  
**Ad on page 101**

**Excavating Equipment****Ditch Witch**

Perry, OK  
800-654-6481 • 580-336-4402  
info@ditchwitch.com  
www.ditchwitch.com

**Environmental Rental Services LTD**

Rockdale, TX  
512-446-7011 • Fax: 512-446-7195  
sterling@ersvacrent.com  
www.ersvacrent.com  
**Ad on page 148**

**Hydra-Flex, Inc.**

Eagan, MN  
952-808-3640 • Fax: 952-808-3650  
sales@hydraflexinc.com  
www.hydraflexinc.com  
**Ad on page 144**

**Premier**

Fort Morgan, CO  
970-542-1975  
sales@poequip.com  
www.poequipment.com

**Sonetics**

Portland, OR  
877-959-9189 • 503-684-7080  
sales@soneticscorp.com  
www.soneticscorp.com/public-works

**Super Products LLC**

New Berlin, WI  
800-837-9711 • 262-784-7110  
info@superproductsllc.com  
www.superproductsllc.com  
**Ad on page 25**

**Vac-Tron Equipment**

Okahumpka, FL  
352-728-2222  
kevin@vacatron.com  
www.vacatron.com

**Vacall - Gradall Industries**

New Philadelphia, OH  
800-382-8302 • 330-339-2211 • Fax: 330-339-8468  
mtnorman@gradall.com  
www.vacall.com  
**Ad on page 33**

**Filter Media****Anthrafilter U.S., Inc.**

Niagara Falls, NY  
800-998-8555 • 716-285-5680 • Fax: 716-285-5681  
swilley@anthrafilter.net  
www.anthrafilter.net  
**Ad on page 147**

**Filters - Wastewater****ABS Materials, Inc.**

Wooster, OH  
330-234-7999  
info@absmaterials.com  
www.abswastewater.com  
**Ad on page 148**

**Anthrafilter U.S., Inc.**

Niagara Falls, NY  
800-998-8555 • 716-285-5680 • Fax: 716-285-5681  
swilley@anthrafilter.net  
www.anthrafilter.net  
**Ad on page 147**

**Komline-Sanderson**

Peapack, NJ  
800-225-5457 • 908-234-1000 • Fax: 908-234-9487  
info@komline.com  
www.komline.com  
**Ad on page 65**

**Red Valve Co. / Tideflex Technologies**

Carnegie, PA  
412-279-0044 • Fax: 412-279-7878  
sales@redvalve.com  
www.redvalve.com  
**Ad on page 19**

**Smith & Loveless, Inc.**

Lenexa, KS  
800-898-9122 • 913-888-5201  
answers@smithandloveless.com  
www.smithandloveless.com

**Westech Engineering**

Salt Lake City, UT  
801-265-1000 • Fax: 801-265-1080  
info@westech-inc.com  
www.westech-inc.com

**Fittings - Sewer & Drain****Agri America, Inc.**

Georgetown, SC  
800-373-2478 • 843-546-0600 • Fax: 843-527-2738  
salesmkg@agriamerica.com  
www.agriamerica.com  
**Ad on page 55**



**HARCO Fittings**

Lynchburg, VA  
434-845-7094 • Fax: 434-845-8562  
sales@harcofittings.com  
www.harcofittings.com  
Ad on page 148



**LADTECH, Inc.**

Lino Lakes, MN  
877-235-7464 • 651-415-1252 • Fax: 651-415-1090  
adjiring@ladtech.com  
www.ladtech.com  
Ad on page 85

**RELINER/Duran Inc.**

Lyme, CT  
800-508-6001 • 860-434-0277 • Fax: 860-434-3195  
duran@reliner.com  
www.reliner.com  
Ad on page 38

**Simple Solutions Distributing LLC**

West Milford, NJ  
866-667-8465 • 973-846-7817 • Fax: 973-858-0219  
sales@industrialodorcontrol.com  
www.IndustrialOdorControl.com  
Ad on page 145

**Fittings - Vacuum**

**Environmental Rental Services LTD**

Rockdale, TX  
512-446-7011 • Fax: 512-446-7195  
sterling@ersvacrent.com  
www.ersvacrent.com  
Ad on page 148

**GapVax, Inc.**

Johnstown, PA  
888-442-7829 • 814-535-6766 • Fax: 814-539-3617  
inquiry@gapvax.com  
www.gapvax.com  
Ad on page 155

**HARCO Fittings**

Lynchburg, VA  
434-845-7094 • Fax: 434-845-8562  
sales@harcofittings.com  
www.harcofittings.com  
Ad on page 148

**Hastings Irrigation Pipe Co.**

Hastings, NE  
800-759-8823 • Fax: 402-463-4355  
gjones@hipco-ne.com  
www.hastingsirrigation.com

**Milwaukee Rubber Products, Inc.**

Menomonee Falls, WI  
800-325-3730 • 262-781-7888 • Fax: 262-781-1742  
dennis@milwaukeeerubber.com  
www.milwaukeeerubber.com  
Ad on page 147

**VARCo**

Manassas, VA  
866-872-1224 • 703-334-5980 • Fax: 703-334-5979  
ron@varcopumper.com  
www.varcopumper.com

**Flange Tools**

**LIFTPLAQ US LLC**

Palmetto Bay, FL  
786-600-1843 • Fax: 855-220-2429  
llc@liftplaq.us  
www.liftplaq.us  
Ad on page 147



**Specialty Maintenance Products, Inc.**

Houston, TX  
713-667-4402 • Fax: 713-669-8618  
sales@smptools.com  
www.smptools.com  
Ad on page 89

**Fleet Management**

**Famhost**

Wichita, KS  
800-658-1676 • 316-267-9910 • Fax: 800-858-2397  
info@famhostapps.com  
www.famhost.com  
Ad on page 56

**Vanair Manufacturing**

Michigan City, IN  
800-526-8817 • 219-879-5100 • Fax: 219-879-5800  
marketing@vanair.com  
www.vanair.com

**Flow Control/Monitoring**

**ADS LLC**

Huntsville, AL  
800-633-7246 • 256-430-3366 • Fax: 256-430-6633  
adssales@idexcorp.com  
www.adsenv.com  
Ad on page 29



**Blue-White Industries**

Huntington Beach, CA  
714-893-8529 • Fax: 714-894-9492  
sales@blue-white.com  
www.blue-white.com  
Ad on page 17



**SALES@FLOWMARK.COM**  
**(855) 653-8100**  
**WWW.FLOWMARK.COM**

**VACUUM TRUCKS**  
**GREASE - RESTROOM**

**SEWAGE - OILFIELD**  
**IN STOCK - OR - CUSTOM BUILT!**





**Data Flow Systems, Inc.**

Melbourne, FL  
321-259-5009 • Fax: 321-259-4006  
www.dataflowsystems.com  
**Ad on page 147**

**Electro Scan Inc.**

Sacramento, CA  
800-975-6149 • 916-779-0660 • Fax: 916-779-0661  
info@electroscan.com  
www.electroscan.com  
**Ad on page 153**

**Endress+Hauser**

Greenwood, IN  
888-363-7377 • Fax: 317-535-8498  
info@us.endress.com  
www.us.endress.com

**FlowWorks Inc.**

Seattle, WA  
206-859-6999 • Fax: 206-320-9939  
sales@flowworks.com  
www.flowworks.com

**Hach - Flow Products & Services**

Loveland, CO  
800-368-2723  
www.hachflow.com

**Hawk Measurement America**

Lawrence, MA  
888-429-5538 • 978-304-3000 • Fax: 978-304-1462  
info@hawkmeasure.com  
www.hawkmeasure.com

**Light Ring Inc.**

McCallsburg, IA  
877-941-2833 • 515-290-8295 • Fax: 515-434-2249  
shane@lightringinc.com  
www.lightringinc.com  
**Ad on page 148**

**Matchpoint Water Asset Management, Inc.**

Wilmington, NC  
910-509-7225 • 910-509-7226  
info@matchpointinc.us  
www.matchpointinc.us  
**Ad on page 133**

**McCrometer Inc.**

Hemet, CA  
800-220-2279 • 951-652-6811 • Fax: 951-652-3078  
customerservice@mccrometer.com  
www.mccrometer.com

**Park Process**

Houston, TX  
855-511-7275 • 713-937-7602 • Fax: 713-937-4254  
rcaughman@parkprocess.com  
www.park-usa.com  
**Ad on page 144**

**PRIMEX**

Detroit Lakes, MN  
888-342-5753 • 218-847-1317 • Fax: 218-847-4617  
info@primexcontrols.com  
www.primexcontrols.com  
**Ad on page 56**

**Proco Products, Inc.**

Stockton, CA  
800-344-3246 • 209-943-6088 • Fax: 209-943-0242  
sales@procoproducts.com  
www.procoproducts.com  
**Ad on page 103**

**Sierra Instruments, Inc.**

Monterey, CA  
800-866-0200 • 831-373-0200 • Fax: 831-373-4402  
info@sierrainstruments.com  
www.sierrainstruments.com

**Singer Valve Inc.**

Surrey, BC  
Canada  
888-764-7858 • 604-594-5404 • Fax: 604-594-8845  
singer@singervalve.com  
www.singervalve.com

**Fume Hoods****HEMCO Corporation**

Independence, MO  
800-779-4362 • 816-796-2900 • Fax: 816-796-3333  
info@hemcocorp.com  
www.hemcocorp.com  
**Ad on page 146**

**Gas Monitors/Detection****Cloverleaf Tool Co.**

Bradenton, FL  
800-365-6583 • 941-739-0707 • Fax: 941-739-0001  
sales@cloverleaftool.com  
www.cloverleaftool.com  
**Ad on page 115**

**Hermann Sewerin GmbH**

D-33334 Gutersloh  
Germany  
888-592-9916 • Fax: 495241934444  
sewerin-usa@sewerin.net  
www.sewerin.com

**JD7 Technologies**

San Diego, CA  
858-242-1640 • Fax: 858-242-1655  
info@jd7usa.com  
www.jd7usa.com

**Matchpoint Water Asset Management, Inc.**

Wilmington, NC  
910-509-7225 • 910-509-7226  
info@matchpointinc.us  
www.matchpointinc.us  
**Ad on page 133**

**Milwaukee Rubber Products, Inc.**

Menomonee Falls, WI  
800-325-3730 • 262-781-7888 • Fax: 262-781-1742  
dennis@milwaukeerubber.com  
www.milwaukeerubber.com  
**Ad on page 147**

**MTech**

Cleveland, OH  
800-362-0240 • 440-646-0996 • Fax: 440-646-9953  
sales@mtechcompany.com  
www.mtechcompany.com  
**Ad on page 146**

**PK Safety**

Alameda, CA  
800-829-9580  
pks-store@pksafety.com  
www.pksafety.com  
**Ad on page 148**

**Pollardwater**

New Hyde Park, NY  
800-437-1146 • Fax: 516-746-0852  
info@pollardwater.com  
www.pollardwater.com

**Pow-r Mole Sales LLC**

Lancaster, NY  
800-344-6653 • 716-683-2486 • Fax: 716-683-6372  
brian@powrmole.com  
www.powrmole.com

**RKI Instruments, Inc.**

Union City, CA  
800-754-5165 • 510-441-5656  
orders@rkiinstruments.com  
www.rkiinstruments.com

**Sewer Equipment Co. of Florida, Inc.**

New Smyrna Beach, FL  
800-635-2323 • 386-428-3303 • Fax: 386-427-4552  
csewerequisite@cfllr.com  
www.sewerequipmentco.com  
**Ad on page 147**

**Sierra Instruments, Inc.**

Monterey, CA  
800-866-0200 • 831-373-0200 • Fax: 831-373-4402  
info@sierrainstruments.com  
www.sierrainstruments.com

**Generators/  
Air Compressors****Generator-Parts.com**

Three Lakes, WI  
715-546-2244  
sales@generator-parts.com  
www.generator-parts.com  
**Ad on page 147**

**KOHLER Power Systems**

Kohler, WI  
800-544-2444 • 920-457-4441 • Fax: 920-459-1646  
generator.feedback@kohler.com  
www.kohlerpower.com

**Sunbelt Rentals**

Fort Mill, SC  
800-736-2504  
www.sunbeltrentals.com  
**Ad on page 139**

**Vanair Manufacturing**

Michigan City, IN  
800-526-8817 • 219-879-5100 • Fax: 219-879-5800  
marketing@vanair.com  
www.vanair.com

**Grease Handling  
Equipment****Boerger, LLC**

Chanhassen, MN  
612-435-7300 • Fax: 612-435-7301  
america@boerger.com  
www.boerger.com

**JWC Environmental**

Santa Ana, CA  
800-331-2277 • 949-833-3888 • Fax: 714-428-4644  
jwce@jwce.com  
www.jwce.com  
**Ad on page 32**

**NozzTeq, Inc.**

Clearwater, FL  
866-620-5915 • 727-223-4979 • Fax: 603-413-6744  
info@nozzteq.com  
www.nozzteq.com  
**Ad on page 105**

**Safe-Tee Chemical Company**

Scottsdale, AZ  
866-366-0587 • 480-968-6828 • Fax: 480-968-6776  
service@safetechemical.com  
www.safetechemical.com  
**Ad on page 145**

**Vaughan Company, Inc.**

Montesano, WA  
888-249-2467 • 360-249-4042 • Fax: 360-249-6155  
info@chopperpumps.com  
www.chopperpumps.com  
**Ad on page 73**

**Grease Interceptors****Best Management Products, Inc.**

Lyme, CT  
800-504-8008 • 410-687-6256 • Fax: 877-434-3197  
tjm@bmpinc.com  
www.bmpinc.com  
**Ad on page 24**

**IPEX USA LLC**

Pineville, NC  
800-463-9572 • 704-889-2431 • Fax: 905-844-0826  
sales@ipexamerica.com  
www.enduragrease.com

**JWC Environmental**

Santa Ana, CA  
800-331-2277 • 949-833-3888 • Fax: 714-428-4644  
jwce@jwce.com  
www.jwce.com  
**Ad on page 32**

**Park Process**

Houston, TX  
855-511-7275 • 713-937-7602 • Fax: 713-937-4254  
rcaughman@parkprocess.com  
www.park-usa.com  
**Ad on page 144**



## Ground Penetrating Radar

### Advanced Infrastructure Technologies, LLC

Torrance, CA  
844-669-9537 • 310-534-4000 • Fax: 310-534-4020  
jp@advancedworld.com  
www.advancedworld.com

Ad on page 8

### SubSurface Instruments, Inc.

De Pere, WI  
855-422-6346 • 920-347-1788 • Fax: 920-347-1791  
paul.renard@ssilocators.com  
www.ssilocators.com

Ad on page 144

## Grouting

**ARIES**  
INDUSTRIES, INC.

### Aries Industries, Inc.

Waukesha, WI  
800-234-7205 • 262-896-7205  
sales@ariesindustries.com  
www.ariesindustries.com

Ad on page 123

### Avanti International

Houston, TX  
800-877-2570 • 281-486-5600 • Fax: 281-486-7300  
sales@avantigrout.com  
www.avantigrout.com



### CUES

Orlando, FL  
800-327-7791 • 407-849-0190 • Fax: 407-425-1569  
salesinfo@cuesinc.com  
www.cuesinc.com

Ad on page 15



### Logiball, Inc.

Quebec, QC  
Canada  
800-246-5988 • 418-656-9767 • Fax: 418-653-5746  
info@logiball.com  
www.logiball.com/en

### Prime Resins

Conyers, GA  
800-321-7212 • 770-388-0626 • Fax: 770-388-0936  
info@primeresins.com  
www.primeresins.com

Ad on page 144

### Sealing Systems, Inc.

Loretto, MN  
800-478-2054 • 763-478-2057 • Fax: 763-478-8868  
pam@ssisealingsystems.com  
www.ssisealingsystems.com

Ad on page 101

**SIMPSON**

**Strong-Tie**

### Simpson Strong-Tie Company, Inc.

Pleasanton, CA  
800-925-5099 • Fax: 925-847-1603  
web@strongtie.com  
www.strongtie.com

Ad on page 7

### Source One Environmental

Davison, MI  
877-450-3701  
info@s1eonline.com  
www.s1eonline.com

## Hand Tools

### Footage Tools, Inc.

Vaughan, ON  
Canada  
888-737-3668 • Fax: 905-695-8874  
bf@footage.ca  
www.footagetools.com

Ad on page 146

### ICS - Blount Inc.

Portland, OR  
800-321-1240 • Fax: 503-653-4393  
marketing@icsdiamondtools.com  
www.icsdiamondtools.com

### LIFTPLAQ US LLC

Palmetto Bay, FL  
786-600-1843 • Fax: 855-220-2429  
llc@liftplaq.us  
www.liftplaq.us

Ad on page 147

### Milwaukee Rubber Products, Inc.

Menomonee Falls, WI  
800-325-3730 • 262-781-7888 • Fax: 262-781-1742  
dennis@milwaukeeerubber.com  
www.milwaukeeerubber.com

Ad on page 147

### Plasticworks, Div of Lewis Plastics

Addison, IL  
630-543-1750 • Fax: 630-543-4611  
chuck@plasticworks.com  
www.plasticworks.com

Ad on page 144

### Reed Manufacturing Co.

Erie, PA  
800-666-3691 • 814-452-3691 • Fax: 814-455-1697  
reedsales@reedmfgco.com  
www.reedmfgco.com

Ad on page 99

## NEWEST MEMBER OF THE HYMAX® FAMILY THE TWO-BOLT HYMAX CLAMP\*

# HYMAX®

Repair the past. Connect the future.



- Only 2 bolts = less time in the ditch\*
- The most durable permanent repair clamp
- Available in nominal sizes 3"-12"
- Extra-wide working range of up to 1.60"

### FAMILY MEMBERS



HYMAX COUPLING



HYMAX VERSA



HYMAX GRIP



**KRAUSZ** is the creator of HYMAX

\*Product lengths of 15" and higher have more than 2 bolts

For more info, visit krauszusa.com or call 855-457-2879 (855-4KRAUSZ)



**RIDGID**

Elyria, OH  
800-769-7743 • 440-323-5581 • Fax: 440-329-4862  
RIDGIDinfo@emerson.com  
www.RIDGID.com

**Sewer Equipment Co. of Florida, Inc.**

New Smyrna Beach, FL  
800-635-2323 • 386-428-3303 • Fax: 386-427-4552  
cseweringequipment@cfl.rr.com  
www.seweringequipmentco.com  
**Ad on page 147**

**Southland Tool Mfg. Inc.**

Anaheim, CA  
714-632-8198 • Fax: 714-632-8228  
sales@southlandtool.com  
www.southlandtool.com  
**Ad on page 47**

**Sunbelt Rentals**

Fort Mill, SC  
800-736-2504  
www.sunbeltrentals.com  
**Ad on page 139**

**T&T Tools, Inc.**

Spring Lake, MI  
800-521-6893 • Fax: 800-521-3260  
sales@mightyprobe.com  
www.mightyprobe.com  
**Ad on page 103**

**Trumbull Industries, Inc.**

Youngstown, OH  
800-677-1799 • 330-799-3333 • Fax: 330-392-0756  
info-mfg@trumbull.com  
www.trumbull-mfg.com  
**Ad on page 12**

**Horizontal Directional Drilling****Ditch Witch**

Perry, OK  
800-654-6481 • 580-336-4402  
info@ditchwitch.com  
www.ditchwitch.com

**Joe Johnson Equipment, Inc.**

Innisfil, ON  
Canada  
800-263-1262 • 705-733-7700 • Fax: 707-733-8800  
info@jjei.com  
www.jjei.com

**McLaughlin Group**

Greenville, SC  
800-435-9340 • 864-277-5870 • Fax: 864-235-9661  
mmole@mightymole.com  
www.mclaughlinunderground.com

**Miller Pipeline**

Indianapolis, IN  
800-428-3742 • 317-293-0278  
www.millerpipeline.com  
**Ad on page 71**

**Pow-r Mole Sales LLC**

Lancaster, NY  
800-344-6653 • 716-683-2486 • Fax: 716-683-6372  
brian@powrmole.com  
www.powrmole.com

**Sonetics**

Portland, OR  
877-959-9189 • 503-684-7080  
sales@soneticscorp.com  
www.soneticscorp.com/public-works

**Vanair Manufacturing**

Michigan City, IN  
800-526-8817 • 219-879-5100 • Fax: 219-879-5800  
marketing@vanair.com  
www.vanair.com

**Hose - High Pressure****Advanced Infrastructure Technologies, LLC**

Torrance, CA  
844-669-9537 • 310-534-4000 • Fax: 310-534-4020  
jp@advancedworld.com  
www.advancedworld.com  
**Ad on page 8**

**American Jetter**

Knoxville, TN  
866-944-3569 • 865-524-4647 • Fax: 865-247-5105  
andy@americanjetter.com  
www.americanjetter.com  
**Ad on page 148**

**Cloverleaf Tool Co.**

Bradenton, FL  
800-365-6583 • 941-739-0707 • Fax: 941-739-0001  
sales@cloverleaftool.com  
www.cloverleaftool.com  
**Ad on page 115**

**Dultmeier Sales**

Omaha, NE  
800-228-9666 • 402-333-1444 • Fax: 402-333-5546  
mhansen@dultmeier.com  
www.dultmeier.com

**GapVax, Inc.**

Johnstown, PA  
888-442-7829 • 814-535-6766 • Fax: 814-539-3617  
inquiry@gapvax.com  
www.gapvax.com  
**Ad on page 155**

**Hammelmann Corp.**

Dayton, OH  
800-783-4935 • 937-859-8777 • Fax: 937-859-9188  
mail@hammelmann.com  
www.hammelmann.com

**Milwaukee Rubber Products, Inc.**

Menomonee Falls, WI  
800-325-3730 • 262-781-7888 • Fax: 262-781-1742  
dennis@milwaukeeerubber.com  
www.milwaukeeerubber.com  
**Ad on page 147**

**NLB Corp.**

Wixom, MI  
800-227-7652 • 248-624-5555  
nlbmtg@nlbusa.com  
www.nlbcorp.com

**NozzTeq, Inc.**

Clearwater, FL  
866-620-5915 • 727-223-4979 • Fax: 603-413-6744  
info@nozzteq.com  
www.nozzteq.com  
**Ad on page 105**

**Sewer Equipment Co. of Florida, Inc.**

New Smyrna Beach, FL  
800-635-2323 • 386-428-3303 • Fax: 386-427-4552  
cseweringequipment@cfl.rr.com  
www.seweringequipmentco.com  
**Ad on page 147**

**Sunbelt Rentals**

Fort Mill, SC  
800-736-2504  
www.sunbeltrentals.com  
**Ad on page 139**

**Super Products LLC**

New Berlin, WI  
800-837-9711 • 262-784-710  
info@superproductsllc.com  
www.superproductsllc.com  
**Ad on page 25**

**Vactor Manufacturing**

Streator, IL  
800-627-3171 • 815-672-3171 • Fax: 815-672-2779  
sales@vactor.com  
www.vactor.com  
**Ad on page 3**

**Vacuum Sales, Inc.**

Lindenwood, NJ  
800-547-7790 • 856-627-7790 • Fax: 856-627-3044  
sales@vacuumsalesinc.com  
www.vacuumsalesinc.com

**VARCo**

Manassas, VA  
866-872-1224 • 703-334-5980 • Fax: 703-334-5979  
ron@varcopumper.com  
www.varcopumper.com

**Water Cannon, Inc. - MWBE**

Lake Mary, FL  
800-333-9274 • 321-800-5763 • Fax: 888-928-9274  
sales@watercannon.com  
www.watercannon.com/catalogrequest.aspx  
**Ads on pages 119, 145**

**Hose - Vacuum****Cloverleaf Tool Co.**

Bradenton, FL  
800-365-6583 • 941-739-0707 • Fax: 941-739-0001  
sales@cloverleaftool.com  
www.cloverleaftool.com  
**Ad on page 115**

**Milwaukee Rubber Products, Inc.**

Menomonee Falls, WI  
800-325-3730 • 262-781-7888 • Fax: 262-781-1742  
dennis@milwaukeeerubber.com  
www.milwaukeeerubber.com  
**Ad on page 147**

**Hose Reels****Cloverleaf Tool Co.**

Bradenton, FL  
800-365-6583 • 941-739-0707 • Fax: 941-739-0001  
sales@cloverleaftool.com  
www.cloverleaftool.com  
**Ad on page 115**

**Dultmeier Sales**

Omaha, NE  
800-228-9666 • 402-333-1444 • Fax: 402-333-5546  
mhansen@dultmeier.com  
www.dultmeier.com

**GapVax, Inc.**

Johnstown, PA  
888-442-7829 • 814-535-6766 • Fax: 814-539-3617  
inquiry@gapvax.com  
www.gapvax.com  
**Ad on page 155**

**General Pump**

Mendota Heights, MN  
888-474-5487 • 651-454-6500 • Fax: 651-454-8015  
sales@gpcompanies.com  
www.generalpump.com

**Hi-Vac Corporation**

Marietta, OH  
800-752-2400 • 740-374-2306 • Fax: 740-374-5447  
sales@x-vac.com  
www.x-vac.com  
**Ad on page 151**

**Infrastructure Repair Systems Inc.**

St. Petersburg, FL  
877-327-4216 • Fax: 727-327-4118  
irsi@irsi.net  
www.irsi.net  
**Ad on page 46**

**K&W Products, Inc.**

Elberta, AL  
800-503-0076 • 251-986-7900 • Fax: 251-986-7902  
sales@kwproducts.net  
www.kwmiequipment.com  
**Ad on page 147**

**Milwaukee Rubber Products, Inc.**

Menomonee Falls, WI  
800-325-3730 • 262-781-7888 • Fax: 262-781-1742  
dennis@milwaukeeerubber.com  
www.milwaukeeerubber.com  
**Ad on page 147**

**PCI Manufacturing Solutions**

Sulphur Springs, TX  
800-256-5633 • 903-439-6999 • Fax: 903-885-7070  
marketing@pcimfgsolutions.com  
www.pcimfgsolutions.com

**Reelcraft Industries**

Columbia City, IN  
800-444-3134 • 260-248-8188 • Fax: 260-248-2605  
reelcraft@reelcraft.com  
www.reelcraft.com  
**Ad on page 145**



**Root Rat**

Bolivar, OH  
800-288-7873 • 330-874-4300 • Fax: 330-874-4448  
chempure@gmail.com  
www.rootrat.net  
**Ad on page 111**

**Sewer Equipment Co. of Florida, Inc.**

New Smyrna Beach, FL  
800-635-2323 • 386-428-3303 • Fax: 386-427-4552  
csewerequipment@cfl.rr.com  
www.sewerequipmentco.com  
**Ad on page 147**

**Water Cannon, Inc. - MWBE**

Lake Mary, FL  
800-333-9274 • 321-800-5763 • Fax: 888-928-9274  
sales@watercannon.com  
www.watercannon.com/catalogrequest.aspx  
**Ads on pages 119, 145**

**Hydrant Lock**

**Plasticworks, Div of Lewis Plastics**

Addison, IL  
630-543-1750 • Fax: 630-543-4611  
chuck@plasticworks.com  
www.plasticworks.com  
**Ad on page 144**

**Hydrants**

**Mueller Co.**

**Mueller Co.**  
Chattanooga, TN  
800-423-1323 • 423-209-4800 • Fax: 423-209-4850  
moreinfo@muellercompany.com  
www.muellercompany.com

**The Plug Hug**

Bellville, OH  
719-313-2791 • Fax: 419-525-2386  
douglasmrshall@theplughug.com  
www.theplughug.com  
**Ad on page 145**

**Hydraulic Parts and Components**

**Cloverleaf Tool Co.**

Bradenton, FL  
800-365-6583 • 941-739-0707 • Fax: 941-739-0001  
sales@cloverleaftool.com  
www.cloverleaftool.com  
**Ad on page 115**

**Sewer Equipment Co. of Florida, Inc.**

New Smyrna Beach, FL  
800-635-2323 • 386-428-3303 • Fax: 386-427-4552  
csewerequipment@cfl.rr.com  
www.sewerequipmentco.com  
**Ad on page 147**

**The Plug Hug**

Bellville, OH  
719-313-2791 • Fax: 419-525-2386  
douglasmrshall@theplughug.com  
www.theplughug.com  
**Ad on page 145**

**Hydroexcavation Equipment**

**3T Equipment Company Inc.**

Santa Rosa, CA  
800-969-3001 • 707-543-8555 • Fax: 707-543-8558  
titequip@yahoo.com  
www.3tequipco.com  
**Ad on page 115**

**Advanced Infrastructure Technologies, LLC**

Torrance, CA  
844-669-9537 • 310-534-4000 • Fax: 310-534-4020  
ip@advancedworld.com  
www.advancedworld.com  
**Ad on page 8**



**Comet USA**  
Burnsville, MN  
800-708-1894 • 952-707-1894 • Fax: 952-707-1895  
cometpump@cometpump.com  
www.cometpump.com

**Ditch Witch**

Perry, OK  
800-654-6481 • 580-336-4402  
info@ditchwitch.com  
www.ditchwitch.com

**Environmental Rental Services LTD**

Rockdale, TX  
512-446-7011 • Fax: 512-446-7195  
sterling@ersvacrent.com  
www.ersvacrent.com  
**Ad on page 148**



**Enz USA, Inc.**  
Aurora, IL  
877-369-8721 • 630-692-7880 • Fax: 630-692-7885  
sales@enzusainc.com  
www.enzusainc.com  
**Ad on page 77**

ENGINE DRIVEN   DIAPHRAGM   HIGH PRESSURE/FIRE   SELF PRIMING ELECTRIC   STRAIGHT CENTRIFUGAL   HVAC/BOOSTER   COOLANT   SUBMERSIBLE   DRUM PUMPS

**Please visit us at www.amtpump.com**

ENGINE DRIVEN   DIAPHRAGM   HIGH PRESSURE/FIRE   SELF PRIMING ELECTRIC   STRAIGHT CENTRIFUGAL   HVAC/BOOSTER   COOLANT   SUBMERSIBLE   DRUM PUMPS



**GapVax, Inc.**

Johnstown, PA  
888-442-7829 • 814-535-6766 • Fax: 814-539-3617  
inquiry@gapvax.com  
www.gapvax.com

**Ad on page 155****Hi-Vac Corporation**

Marietta, OH  
800-752-2400 • 740-374-2306 • Fax: 740-374-5447  
sales@x-vac.com  
www.x-vac.com

**Ad on page 151****Hurco Technologies, Inc.**

Harrisburg, SD  
800-888-1436 • 605-743-2466  
info@hurcotech.com  
www.hurcotech.com

**Ad on page 20****Hydra-Flex, Inc.**

Eagan, MN  
952-808-3640 • Fax: 952-808-3650  
sales@hydratflexinc.com  
www.hydratflexinc.com

**Ad on page 144****Joe Johnson Equipment, Inc.**

Innisfil, ON  
Canada  
800-263-1262 • 705-733-7700 • Fax: 707-733-8800  
info@jjei.com  
www.jjei.com

**KEG Technologies, Inc.**

Spartanburg, SC  
866-595-0515 • 864-804-6637 • Fax: 864-804-6629  
sales@kegtechnologies.net  
www.kegtechnologies.net

**Ad on page 107****McLaughlin Group**

Greenville, SC  
800-435-9340 • 864-277-5870 • Fax: 864-235-9661  
mmole@mightymole.com  
www.mclaughlinunderground.com

**NLB Corp.**

Wixom, MI  
800-227-7652 • 248-624-5555  
nlbmtg@nlbusa.com  
www.nlbcorp.com

**NozzTeq, Inc.**

Clearwater, FL  
866-620-5915 • 727-223-4979 • Fax: 603-413-6744  
info@nozzteq.com  
www.nozzteq.com

**Ad on page 105****Premier****Premier**

Fort Morgan, CO  
970-542-1975  
sales@poequip.com  
www.poequipment.com

**Ring-O-Matic, Inc.**

Pella, IA  
800-544-2518 • 641-628-1515  
jzylstra@ring-o-matic.com  
www.ring-o-matic.com

**Sewer Equipment**

Dixon, IL  
888-477-7611  
sales@sewerequipment.com  
www.sewerequipment.com

**Ad on page 149****Soil Surgeon, Inc.**

Laguna Niguel, CA  
949-363-1401 • Fax: 714-434-9998  
bbain@calhaz.com  
www.soilsurgeoninc.com

**SubSurface Instruments, Inc.**

De Pere, WI  
855-422-6346 • 920-347-1788 • Fax: 920-347-1791  
paul.renard@ssillocators.com  
www.ssillocators.com

**Ad on page 144****Super Products LLC**

New Berlin, WI  
800-837-9711 • 262-784-710  
info@superproductslc.com  
www.superproductslc.com

**Ad on page 25****USB - Sewer Equipment Corporation**

Marietta, GA  
866-408-2814 • 770-984-8880 • Fax: 770-984-2802  
info@usbsec.com  
www.usbsec.com

**Ad on page 69****Vac-Con, Inc.**

Green Cove Springs, FL  
904-284-4200 • Fax: 904-284-3305  
vns@vac-con.com  
www.vac-con.com

**Ad on page 156****Vac-Tron Equipment**

Okahumpka, FL  
352-728-2222  
kevin@vacatron.com  
www.vacatron.com

**Vacall - Gradall Industries**

New Philadelphia, OH  
800-382-8302 • 330-339-2211 • Fax: 330-339-8468  
mfnorman@gradall.com  
www.vacall.com

**Ad on page 33****Vector Manufacturing**

Streator, IL  
800-627-3171 • 815-672-3171 • Fax: 815-672-2779  
sales@vactor.com  
www.vactor.com

**Ad on page 3****Vacuum Sales, Inc.**

Lindenwold, NJ  
800-547-7790 • 856-627-7790 • Fax: 856-627-3044  
sales@vacuumsalesinc.com  
www.vacuumsalesinc.com

**I & I Prevention****Avanti International**

Houston, TX  
800-877-2570 • 281-486-5600 • Fax: 281-486-7300  
sales@avantigrout.com  
www.avantigrout.com

**CCI Pipeline Systems**

Breaux Bridge, LA  
800-867-2772 • 337-332-5808 • Fax: 337-332-5809  
sales@ccipipe.com  
www.ccipipe.com

**CreteX Specialty Products**

Waukesha, WI  
800-345-3764 • 262-542-8153 • Fax: 262-542-0301  
info@cretexseals.com  
www.cretexseals.com

**Ad on page 24****Hurco Technologies, Inc.**

Harrisburg, SD  
800-888-1436 • 605-743-2466  
info@hurcotech.com  
www.hurcotech.com

**Ad on page 20****HydraTech Engineered Products**

Cincinnati, OH  
513-827-9169 • Fax: 513-827-9171  
info@hydrattechllc.com  
www.hydrattechllc.com

**Ad on page 145**

**LADTECH, Inc.**  
Lino Lakes, MN  
877-235-7464 • 651-415-1252 • Fax: 651-415-1090  
adjring@ladtech.com  
www.ladtech.com

**Ad on page 85**

**LIFTPLAQ US LLC**

Palmetto Bay, FL  
786-600-1843 • Fax: 855-220-2429  
llc@liftplaq.us  
www.liftplaq.us

**Ad on page 147****Linabond, Inc.**

Camarillo, CA  
805-484-7373  
info@linabond.com  
www.linabond.com

**LMK Technologies**

Ottawa, IL  
815-433-1275 • Fax: 815-433-0107  
info@lmktechnologies.com  
www.lmktechnologies.com

**Ad on page 143****Logiball, Inc.**

Quebec, QC  
Canada  
800-246-5988 • 418-656-9767 • Fax: 418-653-5746  
info@logiball.com  
www.logiball.com/en

**Miller Pipeline**

Indianapolis, IN  
800-428-3742 • 317-293-0278  
www.millerpipeline.com

**Ad on page 71****Mr. Manhole**

Delphos, OH  
419-741-9075 • Fax: 419-692-1600  
sales@mrmanhole.com  
www.mrmanhole.com

**Ad on page 55****Park Process**

Houston, TX  
855-511-7275 • 713-937-7602 • Fax: 713-937-4254  
rcaughman@parkprocess.com  
www.park-usa.com

**Ad on page 144**

**Perma-Liner Industries, LLC**  
Clearwater, FL  
866-336-2568 • 727-507-9749 • Fax: 727-507-9849  
info@perma-liner.com  
www.perma-liner.com

**Ad on page 5**

**Prime Resins**

Conyers, GA  
800-321-7212 • 770-388-0626 • Fax: 770-388-0936  
info@primeresins.com  
www.primeresins.com

**Ad on page 144****R.S. Technical Services Inc.**

Petaluma, CA  
800-767-1974 • 707-778-1974 • Fax: 707-778-1981  
sales.info@rstechserv.com  
www.rstechserv.com

**Ad on page 31**

**Reline America, Inc.**  
Saltville, VA  
276-496-4000 • Fax: 276-496-4870  
info@relineamerica.com  
www.relineamerica.com

**Ad on page 11**

**Sauereisen, Inc.**

Pittsburgh, PA  
800-444-8235 • 412-963-0303 • Fax: 412-963-7620  
jedavis@sauereisen.com  
www.sauereisen.com

**Ad on page 38****Sealing Systems, Inc.**

Loretto, MN  
800-478-2054 • 763-478-2057 • Fax: 763-478-8868  
pam@ssisealingsystems.com  
www.ssisealingsystems.com

**Ad on page 101**



**SIMPSON**  
**Strong-Tie**

**Simpson Strong-Tie Company, Inc.**

Pleasanton, CA  
800-925-5099 • Fax: 925-847-1603  
web@strongtie.com  
www.strongtie.com

Ad on page 7

**Source One Environmental**

Davison, MI  
877-450-3701  
info@s1eonline.com  
www.s1eonline.com

**Trelleborg Pipe Seals Milford, Inc.**

Milford, NH  
800-626-2180 • 603-673-8680 • Fax: 603-673-7271  
simon.burke@trelleborg.com  
www.trelleborg.com/pipe-seals

Ad on page 144



**Whirlygig, Inc.**

Caldwell, ID  
800-307-4263 • Fax: 208-454-2093  
info@wgig.us  
www.wgig.us

**Inspection - Acoustic**

**General Pipe Cleaners**  
McKees Rocks, PA  
800-245-6200 • 412-771-6300  
info@drainbrain.com  
www.drainbrain.com

**InfoSense, Inc.**  
Charlotte, NC  
877-747-3245 • 704-644-1164 • Fax: 704-930-0145  
achurchill@infosenseinc.com  
www.infosenseinc.com  
Ad on page 95

**JD7 Technologies**

San Diego, CA  
858-242-1640 • Fax: 858-242-1655  
info@jd7usa.com  
www.jd7usa.com

**Inspection - Drainline**



**Aries Industries, Inc.**  
Waukesha, WI  
800-234-7205 • 262-896-7205  
sales@ariesindustries.com  
www.ariesindustries.com  
Ad on page 123



**CUES**  
Orlando, FL  
800-327-7791 • 407-849-0190 • Fax: 407-425-1569  
salesinfo@cuesinc.com  
www.cuesinc.com  
Ad on page 15

**Electro Scan Inc.**

Sacramento, CA  
800-975-6149 • 916-779-0660 • Fax: 916-779-0661  
info@electroscan.com  
www.electroscan.com  
Ad on page 153



**Envirosight**  
Randolph, NJ  
866-936-8476 • 973-252-6700 • Fax: 973-252-1176  
mail@envirosight.com  
www.envirosight.com  
Ad on page 2



**General Pipe Cleaners**  
McKees Rocks, PA  
800-245-6200 • 412-771-6300  
info@drainbrain.com  
www.drainbrain.com

**Milwaukee Rubber Products, Inc.**

Menomonee Falls, WI  
800-325-3730 • 262-781-7888 • Fax: 262-781-1742  
dennis@milwaukeerubber.com  
www.milwaukeerubber.com  
Ad on page 147

**MTech**

Cleveland, OH  
800-362-0240 • 440-646-0996 • Fax: 440-646-9953  
sales@mttechcompany.com  
www.mttechcompany.com  
Ad on page 146



**This is your brain on "CRACKed" Concrete manholes**

- How much do you spend on REHAB?
- How much do you spend on I&I?
- How much do you spend on WORKERS' COMP?



**'LADTECH SYSTEM®' your HDP (recover)E**

**The First alternative to concrete and mortar**

Ladtech Inc. guarantees a full five year limited warranty, if for any reason you return adjustment rings to the manufacturer they will be replaced at no charge.

Ladtech, Inc. 100% recycled HDPE manhole risers provide a watertight system that prevents I&I and costly rehabilitation. A single 4" plastic adjustment ring weighs a mere 12 pounds verses it's concrete counterpart at 180 pounds. It's a no brainer... REALLY!! Visit Ladtech on our website or call for more info: 877-235-7464



Concrete ADJ Rings Installed 1997



Ladtech ADJ Rings Installed 1997



www.ladtech.com



**MyTana Mfg. Company, Inc.**

St. Paul, MN  
800-328-8170 • 651-222-1738 • Fax: 651-222-1739  
mytana@mytana.com  
www.mytana.com

Ad on page 12

**PipeLogix, Inc.**

Palm Desert, CA  
866-299-3150 • 760-779-1700 • Fax: 760-406-6023  
joan.stone@pipelogix.com  
www.pipelogix.com

Ad on page 117

**PipeTech Software**

Ada, MI  
800-262-7817 • 616-676-9811 • Fax: 616-676-9818  
sales@pipetech.tv  
www.pipetech.tv

**Pow-r Mole Sales LLC**

Lancaster, NY  
800-344-6653 • 716-683-2486 • Fax: 716-683-6372  
brian@powrmole.com  
www.powrmole.com

**R.S. Technical Services Inc.**

Petaluma, CA  
800-767-1974 • 707-778-1974 • Fax: 707-778-1981  
sales.info@rstechserv.com  
www.rstechserv.com

Ad on page 31

**RapidView IBAK North America**

Rochester, IN  
800-656-4225 • 574-224-5426 • Fax: 574-223-7953  
info@rapidview.com  
www.rapidview.com

Ad on page 131

**Ratech Electronics, Ltd.**

Concord, ON  
Canada  
800-461-9200 • 905-660-7072 • Fax: 905-660-1519  
sales@ratech-electronics.com  
www.ratech-electronics.com

**Rausch USA**

Chambersburg, PA  
877-728-7241 • 717-709-1005 • Fax: 717-709-1009  
reusa@rauschusa.com  
www.rauschusa.com

**RIDGID**

Elyria, OH  
800-769-7743 • 440-323-5581 • Fax: 440-329-4862  
RIDGIDinfo@emerson.com  
www.RIDGID.com

**Superior Signal Company LLC**

Spotswood, NJ  
800-945-8378 • 732-251-0800 • Fax: 732-251-9442  
info@superiorsignal.com  
www.superiorsignal.com/msw

Ad on page 145

**Triple R Specialty**

Jacksonville, FL  
800-356-9661 • Fax: 904-786-0911  
sales@triplerspecialty.com  
www.triplerspecialty.com

**Vivax-Metrotech Corp.**

Santa Clara, CA  
800-446-3392 • 408-734-1400  
info@vxmt.com  
www.vivax-metrotech.com

Ad on page 154

**Inspection - Mainline****3T Equipment Company Inc.**

Santa Rosa, CA  
800-969-3001 • 707-543-8555 • Fax: 707-543-8558  
ttequip@yahoo.com  
www.3tequipco.com

Ad on page 115

**Aries Industries, Inc.**

Waukesha, WI  
800-234-7205 • 262-896-7205  
sales@ariesindustries.com  
www.ariesindustries.com

Ad on page 123

**Clean Water Works Inc.**

Ottawa, ON  
Canada  
866-695-0155 • 613-745-2444 • Fax: 613-745-9994  
kpeori@cwcanada.com  
www.cwcanada.com

**CUES**

Orlando, FL  
800-327-7791 • 407-849-0190 • Fax: 407-425-1569  
salesinfo@cuesinc.com  
www.cuesinc.com

Ad on page 15

**Electric Eel Mfg.**

Springfield, OH  
800-833-1212 • 937-323-4644 • Fax: 937-323-3767  
info@electriceel.com  
www.electriceel.com

Ad on page 146

**Electro Scan Inc.**

Sacramento, CA  
800-975-6149 • 916-779-0660 • Fax: 916-779-0661  
info@electroscan.com  
www.electroscan.com

Ad on page 153

**Envirosight**

Randolph, NJ  
866-936-8476 • 973-252-6700 • Fax: 973-252-1176  
mail@envirosight.com  
www.envirosight.com

Ad on page 2

**InfoSense, Inc.**

Charlotte, NC  
877-747-3245 • 704-644-1164 • Fax: 704-930-0145  
achurchill@infosenseinc.com  
www.infosenseinc.com

Ad on page 95

**Jack Doheny Companies**

Northville, MI  
800-336-4369 • 248-349-0904 • Fax: 248-349-2774  
info@dohenycompanies.com  
www.dohenycompanies.com

**Joe Johnson Equipment, Inc.**

Innisfil, ON  
Canada  
800-263-1262 • 705-733-7700 • Fax: 707-733-8800  
info@jjei.com  
www.jjei.com

**KEG Technologies, Inc.**

Spartanburg, SC  
866-595-0515 • 864-804-6637 • Fax: 864-804-6629  
sales@kegtechnologies.net  
www.kegtechnologies.net

Ad on page 107

**Light Ring Inc.**

McCallsburg, IA  
877-941-2833 • 515-290-8295 • Fax: 515-434-2249  
shane@lightringinc.com  
www.lightringinc.com

Ad on page 148

**MTech**

Cleveland, OH  
800-362-0240 • 440-646-0996 • Fax: 440-646-9953  
sales@mtechcompany.com  
www.mtechcompany.com

Ad on page 146

**MyTana Mfg. Company, Inc.**

St. Paul, MN  
800-328-8170 • 651-222-1738 • Fax: 651-222-1739  
mytana@mytana.com  
www.mytana.com

Ad on page 12

**PipeLogix, Inc.**

Palm Desert, CA  
866-299-3150 • 760-779-1700 • Fax: 760-406-6023  
joan.stone@pipelogix.com  
www.pipelogix.com

Ad on page 117

**PipeTech Software**

Ada, MI  
800-262-7817 • 616-676-9811 • Fax: 616-676-9818  
sales@pipetech.tv  
www.pipetech.tv

**R.S. Technical Services Inc.**

Petaluma, CA  
800-767-1974 • 707-778-1974 • Fax: 707-778-1981  
sales.info@rstechserv.com  
www.rstechserv.com

Ad on page 31

**RapidView IBAK North America**

Rochester, IN  
800-656-4225 • 574-224-5426 • Fax: 574-223-7953  
info@rapidview.com  
www.rapidview.com

Ad on page 131

**Ratech Electronics, Ltd.**

Concord, ON  
Canada  
800-461-9200 • 905-660-7072 • Fax: 905-660-1519  
sales@ratech-electronics.com  
www.ratech-electronics.com

**Rausch USA**

Chambersburg, PA  
877-728-7241 • 717-709-1005 • Fax: 717-709-1009  
reusa@rauschusa.com  
www.rauschusa.com

**Source One Environmental**

Davison, MI  
877-450-3701  
info@s1eonline.com  
www.s1eonline.com

**Superior Signal Company LLC**

Spotswood, NJ  
800-945-8378 • 732-251-0800 • Fax: 732-251-9442  
info@superiorsignal.com  
www.superiorsignal.com/msw

Ad on page 145

**Trio Vision LLC dba Cobra Tech**

Smyrna, GA  
800-443-3761 • 770-435-8991 • Fax: 770-435-0402  
tomschmandt@cobratec.com  
www.cobratec.com

Ad on page 27





**Vivax-Metrotech Corp.**  
 Santa Clara, CA  
 800-446-3392 • 408-734-1400  
 info@vxmt.com  
 www.vivax-metrotech.com  
**Ad on page 154**

**WinCan, LLC**  
 Pittsburgh, PA  
 877-626-8386 • 412-489-6229  
 sales.us@wincan.com  
 www.wincan.com  
**Ad on page 91**

## Inspection - Manhole/ Confined Space

**Clean Water Works Inc.**  
 Ottawa, ON  
 Canada  
 866-695-0155 • 613-745-2444 • Fax: 613-745-9994  
 kpeori@cwcanada.com  
 www.cwcanada.com

**CUES**  
 Orlando, FL  
 800-327-7791 • 407-849-0190 • Fax: 407-425-1569  
 salesinfo@cuesinc.com  
 www.cuesinc.com  
**Ad on page 15**

**Electro Scan Inc.**  
 Sacramento, CA  
 800-975-6149 • 916-779-0660 • Fax: 916-779-0661  
 info@electroscan.com  
 www.electroscan.com  
**Ad on page 153**

**Environmental Coatings LLC**  
 Mesa, AZ  
 480-984-7608 • Fax: 480-380-4461  
 info@sewershield.com  
 www.sewershield.com



**Envirosight**  
 Randolph, NJ  
 866-936-8476 • 973-252-6700 • Fax: 973-252-1176  
 mail@envirosight.com  
 www.envirosight.com  
**Ad on page 2**

**Hurco Technologies, Inc.**  
 Harrisburg, SD  
 800-888-1436 • 605-743-2466  
 info@hurcotech.com  
 www.hurcotech.com  
**Ad on page 20**

**Jack Doheny Companies**  
 Northville, MI  
 800-336-4369 • 248-349-0904 • Fax: 248-349-2774  
 info@dohenycompanies.com  
 www.dohenycompanies.com

**LIFTPLAQ US LLC**  
 Palmetto Bay, FL  
 786-600-1843 • Fax: 855-220-2429  
 llc@liftplaq.us  
 www.liftplaq.us  
**Ad on page 147**

**Light Ring Inc.**  
 McCallsburg, IA  
 877-941-2833 • 515-290-8295 • Fax: 515-434-2249  
 shane@lightringinc.com  
 www.lightringinc.com  
**Ad on page 148**

**MTEch**  
 Cleveland, OH  
 800-362-0240 • 440-646-0996 • Fax: 440-646-9953  
 sales@mtechcompany.com  
 www.mtechcompany.com  
**Ad on page 146**

**MyTana Mfg. Company, Inc.**  
 St. Paul, MN  
 800-328-8170 • 651-222-1738 • Fax: 651-222-1739  
 mytana@mytana.com  
 www.mytana.com  
**Ad on page 12**



**Pipelogix, Inc.**  
 Palm Desert, CA  
 866-299-3150 • 760-779-1700 • Fax: 760-406-6023  
 joan.stone@pipelogix.com  
 www.pipelogix.com  
**Ad on page 117**

# A Better Way to Limit Manhole Access, The DuraShield Manhole Lock

**DURASHIELD**

- ▼ Strong and durable security
- ▼ Multiple security points
- ▼ Multiple sizes available
- ▼ Easily installed in seconds
- ▼ All stainless steel construction
- ▼ Lightweight—easy to transport
- ▼ Allows draining and venting
- ▼ Requires registered T-Key to unlock
- ▼ Same key can be used with other McGard manhole security products
- ▼ Installed & removed without bending over

1-888-888-9192 or visit us at [www.manholelocks.com](http://www.manholelocks.com)  
 McGard, 3875 California Road, Orchard Park, New York 14127

The Intimidator  
Line Of Security Products



**PipeTech Software**

Ada, MI  
800-262-7817 • 616-676-9811 • Fax: 616-676-9818  
sales@pipetech.tv  
www.pipetech.tv

**PK Safety**

Alameda, CA  
800-829-9580  
pks-store@pksafety.com  
www.pksafety.com  
Ad on page 148

**R.S. Technical Services Inc.**

Petaluma, CA  
800-767-1974 • 707-778-1974 • Fax: 707-778-1981  
sales.info@rstechserv.com  
www.rstechserv.com  
Ad on page 31

**RapidView IBAK North America**

Rochester, IN  
800-656-4225 • 574-224-5426 • Fax: 574-223-7953  
info@rapidview.com  
www.rapidview.com  
Ad on page 131

**Ratech Electronics, Ltd.**

Concord, ON  
Canada  
800-461-9200 • 905-660-7072 • Fax: 905-660-1519  
sales@ratech-electronics.com  
www.ratech-electronics.com

**Sewer Equipment Co. of Florida, Inc.**

New Smyrna Beach, FL  
800-635-2323 • 386-428-3303 • Fax: 386-427-4552  
csewerekquipment@cfllr.com  
www.sewerekquipmentco.com  
Ad on page 147

**Southland Tool Mfg. Inc.**

Anaheim, CA  
714-632-8198 • Fax: 714-632-8228  
sales@southlandtool.com  
www.southlandtool.com  
Ad on page 47

**Trio Vision LLC dba Cobra Tech**

Smyrna, GA  
800-443-3761 • 770-435-8991 • Fax: 770-435-0402  
tomschmandt@cobratec.com  
www.cobratec.com  
Ad on page 27

**Whirlygig, Inc.**

Caldwell, ID  
800-307-4263 • Fax: 208-454-2093  
info@wgig.us  
www.wgig.us

**WinCan, LLC**

Pittsburgh, PA  
877-626-8386 • 412-489-6229  
sales.us@wincan.com  
www.wincan.com  
Ad on page 91

**Inspection - Water Lines**

Orlando, FL  
800-327-7791 • 407-849-0190 • Fax: 407-425-1569  
salesinfo@cuesinc.com  
www.cuesinc.com  
Ad on page 15

**Electro Scan Inc.**

Sacramento, CA  
800-975-6149 • 916-779-0660 • Fax: 916-779-0661  
info@electroscan.com  
www.electroscan.com  
Ad on page 153

**Envirosight**

Randolph, NJ  
866-936-8476 • 973-252-6700 • Fax: 973-252-1176  
mail@envirosight.com  
www.envirosight.com  
Ad on page 2

**HydraTech Engineered Products**

Cincinnati, OH  
513-827-9169 • Fax: 513-827-9171  
info@hydratellc.com  
www.hydratellc.com  
Ad on page 135

**JD7 Technologies**

San Diego, CA  
858-242-1640 • Fax: 858-242-1655  
info@jd7usa.com  
www.jd7usa.com

**Matchpoint Water Asset Management, Inc.**

Wilmington, NC  
910-509-7225 • 910-509-7226  
info@matchpointinc.us  
www.matchpointinc.us  
Ad on page 133

**MyTana Mfg. Company, Inc.**

St. Paul, MN  
800-328-8170 • 651-222-1738 • Fax: 651-222-1739  
mytana@mytana.com  
www.mytana.com  
Ad on page 12

**PipeTech Software**

Ada, MI  
800-262-7817 • 616-676-9811 • Fax: 616-676-9818  
sales@pipetech.tv  
www.pipetech.tv

**RapidView IBAK North America**

Rochester, IN  
800-656-4225 • 574-224-5426 • Fax: 574-223-7953  
info@rapidview.com  
www.rapidview.com  
Ad on page 131

**Ratech Electronics, Ltd.**

Concord, ON  
Canada  
800-461-9200 • 905-660-7072 • Fax: 905-660-1519  
sales@ratech-electronics.com  
www.ratech-electronics.com

**SubSurface Instruments, Inc.**

De Pere, WI  
855-422-6346 • 920-347-1788 • Fax: 920-347-1791  
paul.renard@ssilocators.com  
www.ssilocators.com  
Ad on page 144

**Trio Vision LLC dba Cobra Tech**

Smyrna, GA  
800-443-3761 • 770-435-8991 • Fax: 770-435-0402  
tomschmandt@cobratec.com  
www.cobratec.com  
Ad on page 27

**Triple R Specialty**

Jacksonville, FL  
800-356-9661 • Fax: 904-786-0911  
sales@triplerspecialty.com  
www.triplerspecialty.com

**Instrumentation - Process Control****Blue-White Industries**

Huntington Beach, CA  
714-893-8529 • Fax: 714-894-9492  
sales@blue-white.com  
www.blue-white.com  
Ad on page 17

**CHEMetrics, Inc.**

Midland, VA  
800-356-3072 • 540-788-9026 • Fax: 540-788-4856  
sales@chemetrics.com  
www.chemetrics.com

**Data Flow Systems, Inc.**

Melbourne, FL  
321-259-5009 • Fax: 321-259-4006  
www.dataflowsys.com  
Ad on page 147

**Endress+Hauser**

Greenwood, IN  
888-363-7377 • Fax: 317-535-8498  
info@us.endress.com  
www.us.endress.com

**Hawk Measurement America**

Lawrence, MA  
888-429-5538 • 978-304-3000 • Fax: 978-304-1462  
info@hawkmeasure.com  
www.hawkmeasure.com

**PRIMEX**

Detroit Lakes, MN  
888-342-5753 • 218-847-1317 • Fax: 218-847-4617  
info@primexcontrols.com  
www.primexcontrols.com  
Ad on page 56

**ProComSol, Ltd**

Lakewood, OH  
877-221-1551 • 216-221-1550 • Fax: 216-221-1554  
sales@procomsol.com  
www.procomsol.com  
Ad on page 101

**Reline America, Inc.**

Saltville, VA  
276-496-4000 • Fax: 276-496-4870  
info@relineamerica.com  
www.relineamerica.com  
Ad on page 11

**Sierra Instruments, Inc.**

Monterey, CA  
800-866-0200 • 831-373-0200 • Fax: 831-373-4402  
info@sierrainstruments.com  
www.sierrainstruments.com

**VEGA Americas, Inc.**

Cincinnati, OH  
800-367-5383 • 513-272-0131 • Fax: 513-272-0133  
americas@vega.com  
www.vega.com  
Ad on page 141

**Westech Engineering**

Salt Lake City, UT  
801-265-1000 • Fax: 801-265-1080  
info@westech-inc.com  
www.westech-inc.com

**Jet/Vac Combination Machines****3T Equipment Company Inc.**

Santa Rosa, CA  
800-969-3001 • 707-543-8555 • Fax: 707-543-8558  
titequip@yahoo.com  
www.3tequipco.com  
Ad on page 115

**Clean Water Works Inc.**

Ottawa, ON  
Canada  
866-695-0155 • 613-745-2444 • Fax: 613-745-9994  
kpeori@cwcanada.com  
www.cwcanada.com

**Environmental Rental Services LTD**

Rockdale, TX  
512-446-7011 • Fax: 512-446-7195  
sterling@ersvacrent.com  
www.ersvacrent.com  
Ad on page 148

**Enz USA, Inc.**

Aurora, IL  
877-369-8721 • 630-692-7880 • Fax: 630-692-7885  
sales@enzusainc.com  
www.enzusainc.com  
Ad on page 77

**GapVax, Inc.**

Johnstown, PA  
888-442-7829 • 814-535-6766 • Fax: 814-539-3617  
inquiry@gapvax.com  
www.gapvax.com  
Ad on page 155



**Hi-Vac Corporation**

Marietta, OH  
800-752-2400 • 740-374-2306 • Fax: 740-374-5447  
sales@x-vac.com  
www.x-vac.com

Ad on page 151

**Hot Jet USA**

Riverton, UT  
800-624-8186 • 801-545-0777  
sales@powerlineindustries.com  
www.hotjetusa.com

Ad on page 147

**InfoSense, Inc.**

Charlotte, NC  
877-747-3245 • 704-644-1164 • Fax: 704-930-0145  
achurchill@infosenseinc.com  
www.infosenseinc.com

Ad on page 95

**J. Hvidtved Larsen US, Inc.**

Chicago, IL  
312-705-3818  
jhl@hvidtved.com  
www.hvidtved.com

**Jack Doheny Companies**

Northville, MI  
800-336-4369 • 248-349-0904 • Fax: 248-349-2774  
info@dohenycompanies.com  
www.dohenycompanies.com



**Joe Johnson Equipment, Inc.**

Innisfil, ON  
Canada  
800-263-1262 • 705-733-7700 • Fax: 707-733-8800  
info@jjei.com  
www.jjei.com

**Light Ring Inc.**

McCallsburg, IA  
877-941-2833 • 515-290-8295 • Fax: 515-434-2249  
shane@lightringinc.com  
www.lightringinc.com

Ad on page 148

**McLaughlin Group**

Greenville, SC  
800-435-9340 • 864-277-5870 • Fax: 864-235-9661  
mmole@mightymole.com  
www.mclaughlinunderground.com

**MTech**

Cleveland, OH  
800-362-0240 • 440-646-0996 • Fax: 440-646-9953  
sales@mtechcompany.com  
www.mtechcompany.com

Ad on page 146

**RIDGID**

Elyria, OH  
800-769-7743 • 440-323-5581 • Fax: 440-329-4862  
RIDGIDinfo@emerson.com  
www.RIDGID.com

**Ring-O-Matic, Inc.**

Pella, IA  
800-544-2518 • 641-628-1515  
jzylstra@ring-o-matic.com  
www.ring-o-matic.com

**Sewer Equipment**

Dixon, IL  
888-477-7611  
sales@sewerequipment.com  
www.sewerequipment.com

Ad on page 149

**Sonetics**

Portland, OR  
877-959-9189 • 503-684-7080  
sales@soneticscorp.com  
www.soneticscorp.com/public-works



**Super Products LLC**

New Berlin, WI  
800-837-9711 • 262-784-710  
info@superproductsllc.com  
www.superproductsllc.com

Ad on page 25



USB - Sewer Equipment Corporation

**USB - Sewer Equipment Corporation**

Marietta, GA  
866-408-2814 • 770-984-8880 • Fax: 770-984-2802  
info@usbsec.com  
www.usbsec.com

Ad on page 69



**Vac-Con, Inc.**  
Green Cove Springs, FL  
904-284-4200 • Fax: 904-284-3305  
vns@vac-con.com  
www.vac-con.com  
Ad on page 156

**Vac-Tron Equipment**

Okahumpka, FL  
352-728-2222  
kevin@vactron.com  
www.vactron.com

# SMP VALVE-OUT TOOL

## FLANGE SPREADING & VALVE REPLACEMENT

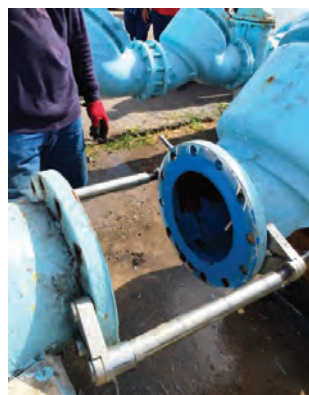

VALVE-OUT TOOL WORKS ON FLANGES WITH BOLT HOLES FROM 3/4" TO 1-3/8" (STUD SIZES 5/8" TO 1-1/4")

CAN BE USED ON ANY VALVE WIDTH

REQUIRES NO GAP AND CAN BE USED TO SPREAD FLANGES AND REPLACE GASKETS

SAFER, FASTER, EASIER

**SPECIALTY MAINTENANCE PRODUCTS, INC.**  
5711 CLAREWOOD DRIVE, SUITE B.  
HOUSTON, TX 77081

EMAIL: [SALES@SMPTOOLS.COM](mailto:SALES@SMPTOOLS.COM)

PHONE: 713-667-4402

**WATCH THE VIDEO HERE** →

WEBSITE: [HTTPS://SMPTOOLS.COM](https://SMPTOOLS.COM)



**VACALL****Vacall - Gradall Industries**

New Philadelphia, OH  
800-382-8302 • 330-339-2211 • Fax: 330-339-8468  
mtnorman@gradall.com  
www.vacall.com

**Ad on page 33**

**Vactor Manufacturing**

Streator, IL  
800-627-3171 • 815-672-3171 • Fax: 815-672-2779  
sales@vactor.com  
www.vactor.com

**Ad on page 3**

**Vacuum Sales, Inc.**

Lindenwold, NJ  
800-547-7790 • 856-627-7790 • Fax: 856-627-3044  
sales@vacuumsalesinc.com  
www.vacuumsalesinc.com

**Jetters - Portable****American Jetter**

Knoxville, TN  
866-944-3569 • 865-524-4647 • Fax: 865-247-5105  
andy@americanjetter.com  
www.americanjetter.com

**Ad on page 148**

**Cam Spray**

Iowa Falls, IA  
800-648-5011 • 641-648-5011 • Fax: 641-648-5013  
sales@camspray.com  
www.camspray.com

**Ad on page 38**

**Environmental Rental Services LTD**

Rockdale, TX  
512-446-7011 • Fax: 512-446-7195  
sterling@ersvacrent.com  
www.ersvacrent.com

**Ad on page 148**

**Enz USA, Inc.**

Aurora, IL  
877-369-8721 • 630-692-7880 • Fax: 630-692-7885  
sales@enzusainc.com  
www.enzusainc.com

**Ad on page 77**

**General  
PIPE CLEANERS****General Pipe Cleaners**

McKees Rocks, PA  
800-245-6200 • 412-771-6300  
info@drainbrain.com  
www.drainbrain.com

**Hammelmann Corp.**

Dayton, OH  
800-783-4935 • 937-859-8777 • Fax: 937-859-9188  
mail@hammelmann.com  
www.hammelmann.com

**Hi-Vac Corporation**

Marietta, OH  
800-752-2400 • 740-374-2306 • Fax: 740-374-5447  
sales@x-vac.com  
www.x-vac.com

**Ad on page 151**

**Hot Jet USA**

Riverton, UT  
800-624-8186 • 801-545-0777  
sales@powerlineindustries.com  
www.hotjetusa.com

**Ad on page 147**

**K&W Products, Inc.**

Elberta, AL  
800-503-0076 • 251-986-7900 • Fax: 251-986-7902  
sales@kwproducts.net  
www.kwmiequipment.com

**Ad on page 147**

**MyTana Mfg. Company, Inc.**

St. Paul, MN  
800-328-8170 • 651-222-1738 • Fax: 651-222-1739  
mytana@mytana.com  
www.mytana.com

**Ad on page 12**

**NozzTek, Inc.**

Clearwater, FL  
866-620-5915 • 727-223-4979 • Fax: 603-413-6744  
info@nozztek.com  
www.nozztek.com

**Ad on page 105**

**Pipeline Renewal Technologies**

Randolph, NJ  
866-936-8476 • 973-252-6700 • Fax: 973-252-1176  
mail@pipelinert.com  
www.pipelinert.com

**Ad on page 37**

**RIDGID**

Elyria, OH  
800-769-7743 • 440-323-5581 • Fax: 440-329-4862  
RIDGIDinfo@emerson.com  
www.RIDGID.com

**Ring-O-Matic, Inc.**

Pella, IA  
800-544-2518 • 641-628-1515  
jzylstra@ring-o-matic.com  
www.ring-o-matic.com

**Root Rat**

Bolivar, OH  
800-288-7873 • 330-874-4300 • Fax: 330-874-4448  
chempure@gmail.com  
www.rootrat.net

**Ad on page 111**

**Sewer Equipment Co. of Florida, Inc.**

New Smyrna Beach, FL  
800-635-2323 • 386-428-3303 • Fax: 386-427-4552  
csewerequipment@cfllr.com  
www.sewerequipmentco.com

**Ad on page 147**

**Spartan Tool**

Mendota, IL  
800-435-3866  
customerservice@spartantool.com  
www.spartantool.com

**Ad on page 21**

**Triple R Specialty**

Jacksonville, FL  
800-356-9661 • Fax: 904-786-0911  
sales@triplerspecialty.com  
www.triplerspecialty.com

**Water Cannon, Inc. - MWBE**

Lake Mary, FL  
800-333-9274 • 321-800-5763 • Fax: 888-928-9274  
sales@watercannon.com  
www.watercannon.com/catalogrequest.aspx

**Ads on pages 119, 145**

**Jetters - Truck & Trailer****3T Equipment Company Inc.**

Santa Rosa, CA  
800-969-3001 • 707-543-8555 • Fax: 707-543-8558  
titequip@yahoo.com  
www.3tequipco.com

**Ad on page 115**

**American Jetter**

Knoxville, TN  
866-944-3569 • 865-524-4647 • Fax: 865-247-5105  
andy@americanjetter.com  
www.americanjetter.com

**Ad on page 148**

**Cam Spray**

Iowa Falls, IA  
800-648-5011 • 641-648-5011 • Fax: 641-648-5013  
sales@camspray.com  
www.camspray.com

**Ad on page 38**

**Environmental Rental Services LTD**

Rockdale, TX  
512-446-7011 • Fax: 512-446-7195  
sterling@ersvacrent.com  
www.ersvacrent.com

**Ad on page 148**

**Enz USA, Inc.**

Aurora, IL  
877-369-8721 • 630-692-7880 • Fax: 630-692-7885  
sales@enzusainc.com  
www.enzusainc.com

**Ad on page 77**

**General Pipe Cleaners**

McKees Rocks, PA  
800-245-6200 • 412-771-6300  
info@drainbrain.com  
www.drainbrain.com

**Hi-Vac Corporation**

Marietta, OH  
800-752-2400 • 740-374-2306 • Fax: 740-374-5447  
sales@x-vac.com  
www.x-vac.com

**Ad on page 151**

**Hot Jet USA**

Riverton, UT  
800-624-8186 • 801-545-0777  
sales@powerlineindustries.com  
www.hotjetusa.com

**Ad on page 147**

**Jack Doheny Companies**

Northville, MI  
800-336-4369 • 248-349-0904 • Fax: 248-349-2774  
info@dohenycompanies.com  
www.dohenycompanies.com

**Joe Johnson Equipment, Inc.**

Innisfil, ON  
Canada  
800-263-1262 • 705-733-7700 • Fax: 707-733-8800  
info@jjei.com  
www.jjei.com

**Ring-O-Matic, Inc.**

Pella, IA  
800-544-2518 • 641-628-1515  
jzylstra@ring-o-matic.com  
www.ring-o-matic.com

**Sewer Equipment**

Dixon, IL  
888-477-7611  
sales@sewerequipment.com  
www.sewerequipment.com

**Ad on page 149**

**Spartan Tool**

Mendota, IL  
800-435-3866  
customerservice@spartantool.com  
www.spartantool.com

**Ad on page 21**

**Super Products LLC**

New Berlin, WI  
800-837-9711 • 262-784-710  
info@superproductslc.com  
www.superproductslc.com

**Ad on page 25**

**Triple R Specialty**

Jacksonville, FL  
800-356-9661 • Fax: 904-786-0911  
sales@triplerspecialty.com  
www.triplerspecialty.com

**Vac-Tron Equipment**

Okahumpka, FL  
352-728-2222  
kevin@vactron.com  
www.vactron.com

**Vactor Manufacturing**

Streator, IL  
800-627-3171 • 815-672-3171 • Fax: 815-672-2779  
sales@vactor.com  
www.vactor.com

**Ad on page 3**

**Vacuum Sales, Inc.**

Lindenwold, NJ  
800-547-7790 • 856-627-7790 • Fax: 856-627-3044  
sales@vacuumsalesinc.com  
www.vacuumsalesinc.com



## Laboratory Equipment/Supplies

### HEMCO Corporation

Independence, MO  
800-779-4362 • 816-796-2900 • Fax: 816-796-3333  
info@hemcocorp.com  
www.hemcocorp.com  
**Ad on page 146**

## Lagoon Products

### American Pleasure Products, Inc.

Rose City, MI  
989-685-2697 • Fax: 989-685-8484  
info@aquacycleusa.com  
www.aquacycleusa.com  
**Ad on page 111**

## Laser Profiling

**CUES**  
Orlando, FL  
800-327-7791 • 407-849-0190 • Fax: 407-425-1569  
salesinfo@cuesinc.com  
www.cuesinc.com  
**Ad on page 15**

### Envirosight

Randolph, NJ  
866-936-8476 • 973-252-6700 • Fax: 973-252-1176  
mail@envirosight.com  
www.envirosight.com  
**Ad on page 2**

### JD7 Technologies

San Diego, CA  
858-242-1640 • Fax: 858-242-1655  
info@jd7usa.com  
www.jd7usa.com

### MTech

Cleveland, OH  
800-362-0240 • 440-646-0996 • Fax: 440-646-9953  
sales@mtechcompany.com  
www.mtechcompany.com  
**Ad on page 146**



### R.S. Technical Services Inc.

Petaluma, CA  
800-767-1974 • 707-778-1974 • Fax: 707-778-1981  
sales.info@rstechserv.com  
www.rstechserv.com  
**Ad on page 31**

### RapidView IBAK North America

Rochester, IN  
800-656-4225 • 574-224-5426 • Fax: 574-223-7953  
info@rapidview.com  
www.rapidview.com  
**Ad on page 131**



### Rausch USA

Chambersburg, PA  
877-728-7241 • 717-709-1005 • Fax: 717-709-1009  
reusa@rauschusa.com  
www.rauschusa.com

## Lift Stations/Wet Wells

### Data Flow Systems, Inc.

Melbourne, FL  
321-259-5009 • Fax: 321-259-4006  
www.dataflowsys.com  
**Ad on page 147**

### Environmental Coatings LLC

Mesa, AZ  
480-984-7608 • Fax: 480-380-4461  
info@sewershield.com  
www.sewershield.com

### Flygt - a Xylem Brand

Charlotte, NC  
855-995-4261  
www.xylem.com/pumping

### Gorman-Rupp Company

Mansfield, OH  
419-755-1011 • Fax: 419-755-1251  
grsales@gormanrupp.com  
www.GRpumps.com

### Hidrostal Pumps

Aurora, IL  
630-948-3355 • Fax: 630-948-3353  
info@hidrostalpumps.com  
www.hidrostalpumps.com

### JWC Environmental

Santa Ana, CA  
800-331-2277 • 949-833-3888 • Fax: 714-428-4644  
jwce@jwce.com  
www.jwce.com  
**Ad on page 32**



### Liberty Pumps

Bergen, NY  
800-543-2550 • 585-494-1817 • Fax: 585-494-1839  
laurie.pfaff@libertypumps.com  
www.libertypumps.com

### Linabond, Inc.

Camarillo, CA  
805-484-7373  
info@linabond.com  
www.linabond.com

## Demand More from Your Data.

It's what our industry has been waiting for—the power to share inspection results in real-time via the cloud, scale for big data, visualize system-wide condition with GIS, plan/track field operations via Google Maps, and generate high-level deliverables like heat maps, budgetary proposals and 3D system models.



sold & supported by:

www.pipelineanalytics.com • (877) 626-8386



collaborate · understand · deliver

real-time  
**insight**



**Park Process**

Houston, TX  
855-511-7275 • 713-937-7602 • Fax: 713-937-4254  
rcaughman@parkprocess.com  
www.park-usa.com

**Ad on page 144**

**Proco Products, Inc.**

Stockton, CA  
800-344-3246 • 209-943-6088 • Fax: 209-943-0242  
sales@procoproducts.com  
www.procoproducts.com

**Ad on page 103**

**RELINER®**  
Duran Inc.

**RELINER/Duran Inc.**

Lyme, CT  
800-508-6001 • 860-434-0277 • Fax: 860-434-3195  
duran@reliner.com  
www.reliner.com

**Ad on page 38**

**Sauereisen, Inc.**

Pittsburgh, PA  
800-444-8235 • 412-963-0303 • Fax: 412-963-7620  
jedavis@sauereisen.com  
www.sauereisen.com

**Ad on page 38**

**Sewer Shield Composite LLC**

Mesa, AZ  
480-830-9537 • Fax: 480-380-4461  
info@sewershieldcomposites.com  
www.sewershieldcomposites.com

**Smith & Loveless, Inc.**

Lenexa, KS  
800-898-9122 • 913-888-5201  
answers@smithandloveless.com  
www.smithandloveless.com

**Specialty Maintenance Products, Inc.**

Houston, TX  
713-667-4402 • Fax: 713-669-8618  
sales@smptools.com  
www.smptools.com

**Ad on page 89**

**Sunbelt Rentals**

Fort Mill, SC  
800-736-2504  
www.sunbeltrentals.com

**Ad on page 139**

**Vaughan Company, Inc.**

Montesano, WA  
888-249-2467 • 360-249-4042 • Fax: 360-249-6155  
info@chopperpumps.com  
www.chopperpumps.com

**Ad on page 73**

**VEGA Americas, Inc.**

Cincinnati, OH  
800-367-5383 • 513-272-0131 • Fax: 513-272-0133  
americas@vega.com  
www.vega.com

**Ad on page 141**

**Zoeller Company**

Louisville, KY  
800-928-7867 • 502-778-2731  
www.zoeller.com

**Liquid Level Indicator****Endress+Hauser**

Greenwood, IN  
888-363-7377 • Fax: 317-535-8498  
info@us.endress.com  
www.us.endress.com

**FlowWorks Inc.**

Seattle, WA  
206-859-6999 • Fax: 206-320-9939  
sales@flowworks.com  
www.flowworks.com

**Hach - Flow Products & Services**

Loveland, CO  
800-368-2723  
www.hachflow.com

**Hawk Measurement America**

Lawrence, MA  
888-429-5538 • 978-304-3000 • Fax: 978-304-1462  
info@hawkmeasure.com  
www.hawkmeasure.com

**PRIMEX**

Detroit Lakes, MN  
888-342-5753 • 218-847-1317 • Fax: 218-847-4617  
info@primexcontrols.com  
www.primexcontrols.com

**Ad on page 56**

**Sierra Instruments, Inc.**

Monterey, CA  
800-866-0200 • 831-373-0200 • Fax: 831-373-4402  
info@sierrainstruments.com  
www.sierrainstruments.com

**Super Products LLC**

New Berlin, WI  
800-837-9711 • 262-784-710  
info@superproductsllc.com  
www.superproductsllc.com

**Ad on page 25**

**VARCo**

Manassas, VA  
866-872-1224 • 703-334-5980 • Fax: 703-334-5979  
ron@varcopumper.com  
www.varcopumper.com

**VEGA Americas, Inc.**

Cincinnati, OH  
800-367-5383 • 513-272-0131 • Fax: 513-272-0133  
americas@vega.com  
www.vega.com

**Ad on page 141**

**WESROC®**  
REMOTE MONITORING SYSTEMS

**WESROC by Independent Technologies, Inc.**

Blair, NE  
866-493-7762 • 402-426-3700 • Fax: 402-426-3705  
tomd@itcmail.net  
www.wesroc.net

**Ad on page 146**

**Locators - Electronic****Advanced Infrastructure Technologies, LLC**

Torrance, CA  
844-669-9537 • 310-534-4000 • Fax: 310-534-4020  
jp@advancedworld.com  
www.advancedworld.com

**Ad on page 8**

**Electro Scan Inc.**

Sacramento, CA  
800-975-6149 • 916-779-0660 • Fax: 916-779-0661  
info@electroscan.com  
www.electroscan.com

**Ad on page 153**

**General Pipe Cleaners**

McKees Rocks, PA  
800-245-6200 • 412-771-6300  
info@drainbrain.com  
www.drainbrain.com

**Hermann Sewerin GmbH**

D-33334 Gutersloh  
Germany  
888-592-9916 • Fax: 495241934444  
sewerin-usa@sewerin.net  
www.sewerin.com

**McLaughlin Group**

Greenville, SC  
800-435-9340 • 864-277-5870 • Fax: 864-235-9661  
mmole@mighthymole.com  
www.mclaughlinunderground.com

**Pow-r Mole Sales LLC**

Lancaster, NY  
800-344-6653 • 716-683-2486 • Fax: 716-683-6372  
brian@powrmole.com  
www.powrmole.com

**RapidView IBAK North America**

Rochester, IN  
800-656-4225 • 574-224-5426 • Fax: 574-223-7953  
info@rapidview.com  
www.rapidview.com

**Ad on page 131**

**Ratech Electronics, Ltd.**

Concord, ON  
Canada  
800-461-9200 • 905-660-7072 • Fax: 905-660-1519  
sales@ratech-electronics.com  
www.ratech-electronics.com

**Spartan Tool**

Mendota, IL  
800-435-3866  
customerservice@spartantool.com  
www.spartantool.com

**Ad on page 21**

**SubSurface Instruments, Inc.**

De Pere, WI  
855-422-6346 • 920-347-1788 • Fax: 920-347-1791  
paul.renard@ssilocators.com  
www.ssilocators.com

**Ad on page 144**

**SubSurface Locators, Inc.**

Incline Village, NV  
775-298-2701 • Fax: 775-298-2703  
sldi@mindspring.com  
www.subsurfaceleak.com

**Ad on page 24**

**WESROC®**  
REMOTE MONITORING SYSTEMS

**WESROC by Independent Technologies, Inc.**

Blair, NE  
866-493-7762 • 402-426-3700 • Fax: 402-426-3705  
tomd@itcmail.net  
www.wesroc.net

**Ad on page 146**

**Locators - Pipe/Leak/  
Valve/Sewer****Advanced Infrastructure Technologies, LLC**

Torrance, CA  
844-669-9537 • 310-534-4000 • Fax: 310-534-4020  
jp@advancedworld.com  
www.advancedworld.com

**Ad on page 8**

**Electro Scan Inc.**

Sacramento, CA  
800-975-6149 • 916-779-0660 • Fax: 916-779-0661  
info@electroscan.com  
www.electroscan.com

**Ad on page 153**

**General Pipe Cleaners**

McKees Rocks, PA  
800-245-6200 • 412-771-6300  
info@drainbrain.com  
www.drainbrain.com

**Hermann Sewerin GmbH**

D-33334 Gutersloh  
Germany  
888-592-9916 • Fax: 495241934444  
sewerin-usa@sewerin.net  
www.sewerin.com

**JD7 Technologies**

San Diego, CA  
858-242-1640 • Fax: 858-242-1655  
info@jd7usa.com  
www.jd7usa.com



**Matchpoint Water Asset Management, Inc.**

Wilmington, NC  
910-509-7225 • 910-509-7226  
info@matchpointinc.us  
www.matchpointinc.us  
**Ad on page 133**

**MTech**

Cleveland, OH  
800-362-0240 • 440-646-0996 • Fax: 440-646-9953  
sales@mttechcompany.com  
www.mttechcompany.com  
**Ad on page 146**

**MyTana Mfg. Company, Inc.**

St. Paul, MN  
800-328-8170 • 651-222-1738 • Fax: 651-222-1739  
mytana@mytana.com  
www.mytana.com  
**Ad on page 12**

**Pollardwater**

New Hyde Park, NY  
800-437-1146 • Fax: 516-746-0852  
info@pollardwater.com  
www.pollardwater.com

**Ratech Electronics, Ltd.**

Concord, ON  
Canada  
800-461-9200 • 905-660-7072 • Fax: 905-660-1519  
sales@ratech-electronics.com  
www.ratech-electronics.com

**Red Valve Co. / Tideflex Technologies**

Carnegie, PA  
412-279-0044 • Fax: 412-279-7878  
sales@redvalve.com  
www.redvalve.com  
**Ad on page 19**

**RIDGID**

Elyria, OH  
800-769-7743 • 440-323-5581 • Fax: 440-329-4862  
RIDGIDinfo@emerson.com  
www.RIDGID.com

**Sewer Equipment Co. of Florida, Inc.**

New Smyrna Beach, FL  
800-635-2323 • 386-428-3303 • Fax: 386-427-4552  
csewerequipment@cfl.rr.com  
www.sewerequipmentco.com  
**Ad on page 147**



**SubSurface Instruments, Inc.**

De Pere, WI  
855-422-6346 • 920-347-1788 • Fax: 920-347-1791  
paul.renard@ssilocators.com  
www.ssilocators.com  
**Ad on page 144**

**SubSurface Locators, Inc.**

Incline Village, NV  
775-298-2701 • Fax: 775-298-2703  
sldi@mindspring.com  
www.subsurfaceleak.com  
**Ad on page 24**

**Superior Signal Company LLC**

Spotswood, NJ  
800-945-8378 • 732-251-0800 • Fax: 732-251-9442  
info@superiorsignal.com  
www.superiorsignal.com/msw  
**Ad on page 145**

**Triple R Specialty**

Jacksonville, FL  
800-356-9661 • Fax: 904-786-0911  
sales@triplerspecialty.com  
www.triplerspecialty.com

**Vactor Manufacturing**

Streator, IL  
800-627-3171 • 815-672-3171 • Fax: 815-672-2779  
sales@vactor.com  
www.vactor.com  
**Ad on page 3**



**Vivax-Metrotech Corp.**

Santa Clara, CA  
800-446-3392 • 408-734-1400  
info@vxmt.com  
www.vivax-metrotech.com  
**Ad on page 154**

**Locators - Smoke/Dye**



**BRIGHT DYES**

**Division of Kingscote Chemicals**

Miamisburg, OH  
800-394-0678 • 937-886-9100 • Fax: 937-886-9300  
sales@kingscotechemicals.com  
www.brightdyes.com  
**Ad on page 145**



weftec 2016  
Booth 955

# CLAMP DOWN ON INVENTORY COSTS!

That's right! The Quick Cam<sup>®</sup> Rapid Seal Repair Clamp features a double range body, allowing a substantial reduction in inventory. No need for extra on-hand sizes for repairing breaks, holes and splits in water and sewer piping.

But that's not all. Check out these features:

- ✓ High Performance = Bigger Safety Factor
- ✓ Slide On -Slide Off Lugs = Low Profile Under Pipe
- ✓ Stainless or Ductile Lugs = Your Choice
- ✓ Rapid Seal = Faster Stop of Leak and Easier to Install

Contact us for complete information.  
Email sales@tps.us or phone 716-372-0160.





**Cloverleaf Tool Co.**

Bradenton, FL  
800-365-6583 • 941-739-0707 • Fax: 941-739-0001  
sales@cloverleaftool.com  
www.cloverleaftool.com

Ad on page 115

**Hurco Technologies, Inc.**

Harrisburg, SD  
800-888-1436 • 605-743-2466  
info@hurcotech.com  
www.hurcotech.com

Ad on page 20

**Sewer Equipment Co. of Florida, Inc.**

New Smyrna Beach, FL  
800-635-2323 • 386-428-3303 • Fax: 386-427-4552  
csewerequipment@cfl.rr.com  
www.sewerequipmentco.com

Ad on page 147

**Superior Signal Company LLC**

Spotswood, NJ  
800-945-8378 • 732-251-0800 • Fax: 732-251-9442  
info@superiorsignal.com  
www.superiorsignal.com/msw

Ad on page 145

**TURBO FOG****Division of Kingscote Chemicals**

Miamisburg, OH  
800-394-0678 • 937-886-9100 • Fax: 937-886-9300  
sales@kingscotechemicals.com  
www.turbo-fog.com

Ad on page 148

**Maintenance/Operations Services****Aqua Operations, Inc.**

Bakersfield, CA  
888-746-6535 • 661-331-1181 • Fax: 661-833-1861  
operator@aquaoptions.com  
www.aquaoptions.com

Ad on page 146

**Manhole Inserts****CreteX Specialty Products**

Waukesha, WI  
800-345-3764 • 262-542-8153 • Fax: 262-542-0301  
info@cretexseals.com  
www.cretexseals.com

Ad on page 24

**LADTECH, Inc.**

Lino Lakes, MN  
877-235-7464 • 651-415-1252 • Fax: 651-415-1090  
adjring@ladtech.com  
www.ladtech.com

Ad on page 85

**McGard LLC**

Orchard Park, NY  
888-888-9192 • 716-662-8980 • Fax: 716-662-8985  
rglass@mcgard.com  
www.manholelocks.com

Ad on page 87

**Mr. Manhole**

Delphos, OH  
419-741-9075 • Fax: 419-692-1600  
sales@mrmanhole.com  
www.mrmanhole.com

Ad on page 55

**Park Process**

Houston, TX  
855-511-7275 • 713-937-7602 • Fax: 713-937-4254  
rcaughman@parkprocess.com  
www.park-usa.com

Ad on page 144

**Parson Environmental Products, Inc.**

Reading, PA  
800-356-9023 • 610-582-6060 • Fax: 610-582-6064  
info@parsonenvironmental.com  
www.parsonenvironmental.com

Ad on page 109

**Pollardwater**

New Hyde Park, NY  
800-437-1146 • Fax: 516-746-0852  
info@pollardwater.com  
www.pollardwater.com

**Sealing Systems, Inc.**

Loretto, MN  
800-478-2054 • 763-478-2057 • Fax: 763-478-8868  
pam@ssisealingsystems.com  
www.ssisealingsystems.com

Ad on page 101

**Sewer Equipment Co. of Florida, Inc.**

New Smyrna Beach, FL  
800-635-2323 • 386-428-3303 • Fax: 386-427-4552  
csewerequipment@cfl.rr.com  
www.sewerequipmentco.com

Ad on page 147

**Sewer Shield Composite LLC**

Mesa, AZ  
480-830-9537 • Fax: 480-380-4461  
info@sewershieldcomposites.com  
www.sewershieldcomposites.com

**Simple Solutions Distributing LLC**

West Milford, NJ  
866-667-8465 • 973-846-7817 • Fax: 973-858-0219  
sales@industrialodorcontrol.com  
www.IndustrialOdorControl.com

Ad on page 145

**The Man Pan**

McMurray, PA  
724-942-9500 • Fax: 724-942-7591  
johnmanning@themanpan.com  
www.themanpan.com

**Whirlygig, Inc.**

Caldwell, ID  
800-307-4263 • Fax: 208-454-2093  
info@wgig.us  
www.wgig.us

**Manhole Parts/Components****American Highway Products, Ltd.**

Bolivar, OH  
888-272-2397 • 330-874-3270 • Fax: 330-874-3800  
sales@ahp1.com  
www.ahp1.com

Ad on page 97

**CreteX Specialty Products**

Waukesha, WI  
800-345-3764 • 262-542-8153 • Fax: 262-542-0301  
info@cretexseals.com  
www.cretexseals.com

Ad on page 24

**LADTECH, Inc.**

Lino Lakes, MN  
877-235-7464 • 651-415-1252 • Fax: 651-415-1090  
adjring@ladtech.com  
www.ladtech.com

Ad on page 85

**LIFTPLAQ US LLC**

Palmetto Bay, FL  
786-600-1843 • Fax: 855-220-2429  
llc@liftplaq.us  
www.liftplaq.us

Ad on page 147

**Light Ring Inc.**

McCallsburg, IA  
877-941-2833 • 515-434-2248 • 515-290-8295  
www.lightringinc.com

Ad on page 148

**McGard LLC**

Orchard Park, NY  
888-888-9192 • 716-662-8980 • Fax: 716-662-8985  
rglass@mcgard.com  
www.manholelocks.com

Ad on page 87

**Milwaukee Rubber Products, Inc.**

Menomonee Falls, WI  
800-325-3730 • 262-781-7888 • Fax: 262-781-1742  
dennis@milwaukeeerubber.com  
www.milwaukeeerubber.com

Ad on page 147

**Mr. Manhole**

Delphos, OH  
419-741-9075 • Fax: 419-692-1600  
sales@mrmanhole.com  
www.mrmanhole.com

Ad on page 55

**Park Process**

Houston, TX  
855-511-7275 • 713-937-7602 • Fax: 713-937-4254  
rcaughman@parkprocess.com  
www.park-usa.com

Ad on page 144

**Parson Environmental Products, Inc.**

Reading, PA  
800-356-9023 • 610-582-6060 • Fax: 610-582-6064  
info@parsonenvironmental.com  
www.parsonenvironmental.com

Ad on page 109

**RELINER/Duran Inc.**

Lyme, CT  
800-508-6001 • 860-434-0277 • Fax: 860-434-3195  
duran@reliner.com  
www.reliner.com

Ad on page 38

**Sewer Shield Composite LLC**

Mesa, AZ  
480-830-9537 • Fax: 480-380-4461  
info@sewershieldcomposites.com  
www.sewershieldcomposites.com

**Thompson Pipe Group**

Rialto, CA  
909-822-0200  
info@thompsonpipegroup.com  
www.thompsonpipegroup.com

Ad on page 46

**Trumbull Industries, Inc.**

Youngstown, OH  
800-677-1799 • 330-799-3333 • Fax: 330-392-0756  
info-mfg@trumbull.com  
www.trumbull-mfg.com

Ad on page 12

**Whirlygig, Inc.**

Caldwell, ID  
800-307-4263 • Fax: 208-454-2093  
info@wgig.us  
www.wgig.us

**Manhole Rehabilitation****A.W. Cook Cement**

Hoschton, GA  
706-654-4706 • Fax: 706-654-3662  
cookcement@windstream.net  
www.awcookcement.com

Ad on page 147





**Abart Industries, LLC**

Skaneateles, NY  
315-730-2588  
dave@tophatrisers.com  
www.tophatrisers.com  
**Ad on page 144**

**American Highway Products, Ltd.**

Bolivar, OH  
888-272-2397 • 330-874-3270 • Fax: 330-874-3800  
sales@ahp1.com  
www.ahp1.com  
**Ad on page 97**



**AP/M Permaform**

Johnston, IA  
800-662-6465 • 515-276-9610 • Fax: 515-276-1274  
info@permaform.net  
www.permaform.net  
**Ad on page 67**

**Avanti International**

Houston, TX  
800-877-2570 • 281-486-5600 • Fax: 281-486-7300  
sales@avantigrout.com  
www.avantigrout.com

**CCI Pipeline Systems**

Breaux Bridge, LA  
800-867-2772 • 337-332-5808 • Fax: 337-332-5809  
sales@ccipipe.com  
www.ccipipe.com

**Clean Water Works Inc.**

Ottawa, ON Canada  
866-695-0155 • 613-745-2444 • Fax: 613-745-9994  
kpeori@cwcanada.com  
www.cwcanada.com

**Cretex Specialty Products**

Waukesha, WI  
800-345-3764 • 262-542-8153 • Fax: 262-542-0301  
info@cretexseals.com  
www.cretexseals.com  
**Ad on page 24**

**Duke's Root Control, Inc.**

Syracuse, NY  
800-447-6687 • 315-472-4781 • Fax: 315-475-4203  
lynn@dukes.com  
www.dukes.com  
**Ad on page 13**

**Environmental Coatings LLC**

Mesa, AZ  
480-984-7608 • Fax: 480-380-4461  
info@sewershield.com  
www.sewershield.com

**Infrastructure Repair Systems Inc.**

St. Petersburg, FL  
877-327-4216 • Fax: 727-327-4118  
irsi@irsi.net  
www.irsi.net  
**Ad on page 46**

**JPCI Services**

Mesa, AZ  
480-986-1212 • Fax: 480-380-4461  
info@jpciservices.com  
www.jpciservices.com



**LADTECH, Inc.**

Lino Lakes, MN  
877-235-7464 • 651-415-1252 • Fax: 651-415-1090  
adjring@ladtech.com  
www.ladtech.com  
**Ad on page 85**

**Lee Supply Company**

Charleroi, PA  
800-353-3747 • 724-483-3543 • Fax: 724-483-0577  
info@leesupply.com  
www.leesupply.com  
**Ad on page 12**

**LIFTPLAQ US LLC**

Palmetto Bay, FL  
786-600-1843 • Fax: 855-220-2429  
llc@liftplaq.us  
www.liftplaq.us  
**Ad on page 147**

**Light Ring Inc.**

McCollsburg, IA  
877-941-2833 • 515-290-8295 • Fax: 515-434-2249  
shane@lightringinc.com  
www.lightringinc.com  
**Ad on page 148**

**Linabond, Inc.**

Camarillo, CA  
805-484-7373  
info@linabond.com  
www.linabond.com

**LMK Technologies**

Ottawa, IL  
815-433-1275 • Fax: 815-433-0107  
info@lmktechnologies.com  
www.lmktechnologies.com  
**Ad on page 143**

**Logiball, Inc.**

Quebec, QC  
Canada  
800-246-5988 • 418-656-9767 • Fax: 418-653-5746  
info@logiball.com  
www.logiball.com/en



**Sewer Line Rapid Assessment Tool**

A new way to focus camera and cleaning resources.

- Less than 1/10<sup>th</sup> the cost of camera inspection
- Patented Active Acoustic technology
- No flow contact
- Reduce cleaning effort by 50% or more
- Screen over 10,000 feet of gravity-fed sewer per day
- Millions of feet inspected
- Train operators in minutes
- Rugged field-tested construction

"It is a revolutionary change to the way collection systems will be managed." – Major Utility Engineer

877-747-3245  
sales@infosenseinc.com  
www.infosenseinc.com

Winner 2012  
WEF Innovative  
Technology  
Award



weftec 2016  
Booth 1541



**Mr. Manhole**

Delphos, OH  
419-741-9075 • Fax: 419-692-1600  
sales@mrmanhole.com  
www.mrmanhole.com

Ad on page 55

**Neopoxy International, Inc.**

Hayward, CA  
510-782-1290 • Fax: 510-782-1292  
epoxy@neopoxy.us  
www.neopoxy.us

Ad on page 146

**Parson Environmental Products, Inc.**

Reading, PA  
800-356-9023 • 610-582-6060 • Fax: 610-582-6064  
info@parsonenvironmental.com  
www.parsonenvironmental.com

Ad on page 109

**Perma-Liner Industries, LLC**

Clearwater, FL  
866-336-2568 • 727-507-9749 • Fax: 727-507-9849  
info@perma-liner.com  
www.perma-liner.com

Ad on page 5

**Prime Resins**

Conyers, GA  
800-321-7212 • 770-388-0626 • Fax: 770-388-0936  
info@primeresins.com  
www.primeresins.com

Ad on page 144

**RELINER/Duran Inc.**

Lyme, CT  
800-508-6001 • 860-434-0277 • Fax: 860-434-3195  
duran@reliner.com  
www.reliner.com

Ad on page 38

**RootX**

Salem, OR  
800-844-4974 • 503-364-2999 • Fax: 503-485-5229  
rootx@rootx.com  
www.rootx.com

Ad on page 39

**Sauereisen, Inc.**

Pittsburgh, PA  
800-444-8235 • 412-963-0303 • Fax: 412-963-7620  
jedavis@sauereisen.com  
www.sauereisen.com

Ad on page 38

**Sealing Systems, Inc.**

Loretto, MN  
800-478-2054 • 763-478-2057 • Fax: 763-478-8868  
pam@ssisealingsystems.com  
www.ssisealingsystems.com

Ad on page 101

**Sewer Equipment Co. of Florida, Inc.**

New Smyrna Beach, FL  
800-635-2323 • 386-428-3303 • Fax: 386-427-4552  
csewerequipment@cfl.rr.com  
www.sewerequipmentco.com

Ad on page 147

**Sewer Shield Composite LLC**

Mesa, AZ  
480-830-9537 • Fax: 480-380-4461  
info@sewershieldcomposites.com  
www.sewershieldcomposites.com

**Simpson Strong-Tie Company, Inc.**

Pleasanton, CA  
800-925-5099 • Fax: 925-847-1603  
web@strongtie.com  
www.strongtie.com

Ad on page 7

**Source One Environmental**

Davison, MI  
877-450-3701  
info@s1eonline.com  
www.s1eonline.com

**Southland Tool Mfg. Inc.**

Anaheim, CA  
714-632-8198 • Fax: 714-632-8228  
sales@southlandtool.com  
www.southlandtool.com

Ad on page 47

**Sunbelt Rentals**

Fort Mill, SC  
800-736-2504  
www.sunbeltrentals.com

Ad on page 139

**The Strong Company, Inc.**

Pine Bluff, AR  
870-535-7617  
info@strongseal.com  
www.strongseal.com

Ad on page 43

**Trelleborg Pipe Seals Milford, Inc.**

Milford, NH  
800-626-2180 • 603-673-8680 • Fax: 603-673-7271  
simon.burke@trelleborg.com  
www.trelleborg.com/pipe-seals

Ad on page 144

**USB - Sewer Equipment Corporation**

Marietta, GA  
866-408-2814 • 770-984-8880 • Fax: 770-984-2802  
info@usbsec.com  
www.usbsec.com

Ad on page 69

**Whirlygig, Inc.**

Caldwell, ID  
800-307-4263 • Fax: 208-454-2093  
info@wgig.us  
www.wgig.us

**Manhole Vacuum Testing****LADTECH, Inc.**

Lino Lakes, MN  
877-235-7464 • 651-415-1252 • Fax: 651-415-1090  
adjring@ladtech.com  
www.ladtech.com

Ad on page 85

**Lansas Mfg. by Vanderlans & Sons Inc.**

Lodi, CA  
800-452-4902 • 209-334-4115 • Fax: 209-339-8260  
sales@lansas.com  
www.lansas.com

**Mr. Manhole**

Delphos, OH  
419-741-9075 • Fax: 419-692-1600  
sales@mrmanhole.com  
www.mrmanhole.com

Ad on page 55

**Sewer Equipment Co. of Florida, Inc.**

New Smyrna Beach, FL  
800-635-2323 • 386-428-3303 • Fax: 386-427-4552  
csewerequipment@cfl.rr.com  
www.sewerequipmentco.com

Ad on page 147

**Whirlygig, Inc.**

Caldwell, ID  
800-307-4263 • Fax: 208-454-2093  
info@wgig.us  
www.wgig.us

**Meter Boxes/  
Components****Ferguson Waterworks**

Newport News, VA  
757-874-7795  
bryan.mokry@ferguson.com  
www.ferguson.com/waterworks

Ad on page 49

**Mueller Co.**

Chattanooga, TN  
800-423-1323 • 423-209-4800 • Fax: 423-209-4850  
moreinfo@muellercompany.com  
www.muellercompany.com

**Meters - Sewer/Flow****ADS LLC**

Huntsville, AL  
800-633-7246 • 256-430-3366 • Fax: 256-430-6633  
adssales@idexcorp.com  
www.adsenv.com

Ad on page 29

**Endress+Hauser**

Greenwood, IN  
888-363-7377 • Fax: 317-535-8498  
info@us.endress.com  
www.us.endress.com

**Hach - Flow Products & Services**

Loveland, CO  
800-368-2723  
www.hachflow.com

**Matchpoint Water Asset Management, Inc.**

Wilmington, NC  
910-509-7225 • 910-509-7226  
info@matchpointinc.us  
www.matchpointinc.us

Ad on page 133

**Parson Environmental Products, Inc.**

Reading, PA  
800-356-9023 • 610-582-6060 • Fax: 610-582-6064  
info@parsonenvironmental.com  
www.parsonenvironmental.com

Ad on page 109

**Sierra Instruments, Inc.**

Monterey, CA  
800-866-0200 • 831-373-0200 • Fax: 831-373-4402  
info@sierrainstruments.com  
www.sierrainstruments.com

**Meters - Water/Flow****Blue-White Industries**

Huntington Beach, CA  
714-893-8529 • Fax: 714-894-9492  
sales@blue-white.com  
www.blue-white.com

Ad on page 17

**CHEMetrics, Inc.**

Midland, VA  
800-356-3072 • 540-788-9026 • Fax: 540-788-4856  
sales@chemetrics.com  
www.chemetrics.com



**Endress+Hauser**  
Greenwood, IN  
888-363-7377 • Fax: 317-535-8498  
info@us.endress.com  
www.us.endress.com



**Hach - Flow Products & Services**  
Loveland, CO  
800-368-2723  
www.hachflow.com

**Matchpoint Water Asset Management, Inc.**  
Wilmington, NC  
910-509-7225 • 910-509-7226  
info@matchpointinc.us  
www.matchpointinc.us  
**Ad on page 133**

**McCrometer Inc.**  
Hemet, CA  
800-220-2279 • 951-652-6811 • Fax: 951-652-3078  
customerservice@mccrometer.com  
www.mccrometer.com

**Park Process**  
Houston, TX  
855-511-7275 • 713-937-7602 • Fax: 713-937-4254  
rcaughman@parkprocess.com  
www.park-usa.com  
**Ad on page 144**

**Sierra Instruments, Inc.**  
Monterey, CA  
800-866-0200 • 831-373-0200 • Fax: 831-373-4402  
info@sierrainstruments.com  
www.sierrainstruments.com

**Singer Valve Inc.**  
Surrey, BC  
Canada  
888-764-7858 • 604-594-5404 • Fax: 604-594-8845  
singer@singervalve.com  
www.singervalve.com

**Mobile Communications**

**Famhost**  
Wichita, KS  
800-658-1676 • 316-267-9910 • Fax: 800-858-2397  
info@famhostapps.com  
www.famhost.com  
**Ad on page 56**

**Sonetics**  
Portland, OR  
877-959-9189 • 503-684-7080  
sales@soneticscorp.com  
www.soneticscorp.com/public-works

**Monitoring Equipment**

**ADS LLC**  
Huntsville, AL  
800-633-7246 • 256-430-3366 • Fax: 256-430-6633  
adsales@idexcorp.com  
www.adsenv.com  
**Ad on page 29**

**Data Flow Systems, Inc.**  
Melbourne, FL  
321-259-5009 • Fax: 321-259-4006  
www.dataflowsys.com  
**Ad on page 147**

**Endress+Hauser**  
Greenwood, IN  
888-363-7377 • Fax: 317-535-8498  
info@us.endress.com  
www.us.endress.com

**Flygt - a Xylem Brand**  
Charlotte, NC  
855-995-4261  
www.xylem.com/pumping

**Hach - Flow Products & Services**  
Loveland, CO  
800-368-2723  
www.hachflow.com

**KOHLER Power Systems**  
Kohler, WI  
800-544-2444 • 920-457-4441 • Fax: 920-459-1646  
generator.feedback@kohler.com  
www.kohlerpower.com

**Matchpoint Water Asset Management, Inc.**  
Wilmington, NC  
910-509-7225 • 910-509-7226  
info@matchpointinc.us  
www.matchpointinc.us  
**Ad on page 133**



**Mueller Co.**  
Chattanooga, TN  
800-423-1323 • 423-209-4800 • Fax: 423-209-4850  
moreinfo@muellercompany.com  
www.muellercompany.com

**Park Process**  
Houston, TX  
855-511-7275 • 713-937-7602 • Fax: 713-937-4254  
rcaughman@parkprocess.com  
www.park-usa.com  
**Ad on page 144**

**PK Safety**  
Alameda, CA  
800-829-9580  
pks-store@pksafety.com  
www.pksafety.com  
**Ad on page 148**



# AMERICAN HIGHWAY PRODUCTS LTD.

## RAISING AMERICA, ONE INCH AT A TIME

**the PIVOTED TURNBUCKLE Manhole Riser**

The Most Efficient and Powerful Expanding Riser on the Market.

Riser heights 3/4" and up in all diameters. 1" diametric variance and DOT approved in most states.

**NEW! INCLINED RISER.** Now you can RAISE & TILT the manhole cover.

Made in the USA

### SAFETY RAMPS

**ELIMINATE**

- Vehicle Damage Claims •
- Material Cost for Cold Patch •
- Labor and Disposal Costs •



MANHOLE SAFETY RAMP

ROAD SURFACE

MILLED SURFACE

SAFETY RAMP

**Catch Basin & Valve Box Risers** reduce costs and streamline adjustments



**I.D. Locator** allows for easy location of common utilities and aids in identifying striping



**Sewer Lid Seal Kit** eliminates lid vibration and reduces moisture penetration



**Rubber Adjusting Ring** protects sub-structure, eliminates noise and vibration



**EZ Lift** will unseat, lift, and set down a manhole cover in one smooth motion



Toll Free 1-888-272-2397 - www.ahp1.com - e-mail: sales@ahp1.com - Free DVD/CD ROM



**PRIMEX**

Detroit Lakes, MN  
888-342-5753 • 218-847-1317 • Fax: 218-847-4617  
info@primexcontrols.com  
www.primexcontrols.com  
**Ad on page 56**

**Reline America, Inc.**

Saltville, VA  
276-496-4000 • Fax: 276-496-4870  
info@relineamerica.com  
www.relineamerica.com  
**Ad on page 11**

**RKI Instruments, Inc.**

Union City, CA  
800-754-5165 • 510-441-5656  
orders@rkiinstruments.com  
www.rkiinstruments.com

**Sunbelt Rentals**

Fort Mill, SC  
800-736-2504  
www.sunbeltrentals.com  
**Ad on page 139**

**WESROC by Independent Technologies, Inc.**

Blair, NE  
866-493-7762 • 402-426-3700 • Fax: 402-426-3705  
tomd@itcmail.net  
www.wesroc.net  
**Ad on page 146**

**Nozzles - High Pressure****3T Equipment Company Inc.**

Santa Rosa, CA  
800-969-3001 • 707-543-8555 • Fax: 707-543-8558  
tfequip@yahoo.com  
www.3tequipco.com  
**Ad on page 115**

**Advanced Infrastructure Technologies, LLC**

Torrance, CA  
844-669-9537 • 310-534-4000 • Fax: 310-534-4020  
jp@advancedworld.com  
www.advancedworld.com  
**Ad on page 8**

**American Jetter**

Knoxville, TN  
866-944-3569 • 865-524-4647 • Fax: 865-247-5105  
andy@americanjetter.com  
www.americanjetter.com  
**Ad on page 148**

**Arthur Products Co.**

Medina, OH  
800-322-0510 • 330-725-4905 • Fax: 330-722-2698  
apc@apcdsq.com  
www.arthurproducts.com  
**Ad on page 56**

**Cloverleaf Tool Co.**

Bradenton, FL  
800-365-6583 • 941-739-0707 • Fax: 941-739-0001  
sales@cloverleaftool.com  
www.cloverleaftool.com  
**Ad on page 115**

**Comet USA**

Burnsville, MN  
800-708-1894 • 952-707-1894 • Fax: 952-707-1895  
cometpump@cometpump.com  
www.cometpump.com

**Ditch Witch**

Perry, OK  
800-654-6481 • 580-336-4402  
info@ditchwitch.com  
www.ditchwitch.com

**Environmental Rental Services LTD**

Rockdale, TX  
512-446-7011 • Fax: 512-446-7195  
sterling@ersvacrent.com  
www.ersvacrent.com  
**Ad on page 148**

**Enz USA, Inc.**

Aurora, IL  
877-369-8721 • 630-692-7880 • Fax: 630-692-7885  
sales@enzusainc.com  
www.enzusainc.com  
**Ad on page 77**

**GapVax, Inc.**

Johnstown, PA  
888-442-7829 • 814-535-6766 • Fax: 814-539-3617  
inquiry@gapvax.com  
www.gapvax.com  
**Ad on page 155**

**General Pipe Cleaners**

McKees Rocks, PA  
800-245-6200 • 412-771-6300  
info@drainbrain.com  
www.drainbrain.com

**General Pump**

Mendota Heights, MN  
888-474-5487 • 651-454-6500 • Fax: 651-454-8015  
sales@gpcompanies.com  
www.generalpump.com

**Giant Industries**

Toledo, OH  
800-633-4565 • 419-531-4600 • Fax: 419-531-6836  
sales@giantpumps.com  
www.giantpumps.com

**Hammelmann Corp.**

Dayton, OH  
800-783-4935 • 937-859-8777 • Fax: 937-859-9188  
mail@hammelmann.com  
www.hammelmann.com

**Hot Jet USA**

Riverton, UT  
800-624-8186 • 801-545-0777  
sales@powerlineindustries.com  
www.hotjetusa.com  
**Ad on page 147**

**Hydra-Flex, Inc.**

Eagan, MN  
952-808-3640 • Fax: 952-808-3650  
sales@hydraflexinc.com  
www.hydraflexinc.com  
**Ad on page 144**

**KEG Technologies, Inc.**

Spartanburg, SC  
866-595-0515 • 864-804-6637 • Fax: 864-804-6629  
sales@kegtechnologies.net  
www.kegtechnologies.net  
**Ad on page 107**

**MyTana Mfg. Company, Inc.**

St. Paul, MN  
800-328-8170 • 651-222-1738 • Fax: 651-222-1739  
mytana@mytana.com  
www.mytana.com  
**Ad on page 12**

**NLB Corp.**

Wixom, MI  
800-227-7652 • 248-624-5555  
nlbmtkg@nlbusa.com  
www.nlbcorp.com

**NozzTeq, Inc.**

Cleawater, FL  
866-620-5915 • 727-223-4979 • Fax: 603-413-6744  
info@nozzteq.com  
www.nozzteq.com  
**Ad on page 105**

**Root Rat**

Bolivar, OH  
800-288-7873 • 330-874-4300 • Fax: 330-874-4448  
chempure@gmail.com  
www.rootrat.net  
**Ad on page 111**

**Sewer Equipment Co. of Florida, Inc.**

New Smyrna Beach, FL  
800-635-2323 • 386-428-3303 • Fax: 386-427-4552  
csewerequipment@cfl.rr.com  
www.sewerequipmentco.com  
**Ad on page 147**

**Southland Tool Mfg. Inc.**

Anaheim, CA  
714-632-8198 • Fax: 714-632-8228  
sales@southlandtool.com  
www.southlandtool.com  
**Ad on page 47**

**Spartan Tool**

Mendota, IL  
800-435-3866  
customerservice@spartantool.com  
www.spartantool.com  
**Ad on page 21**

**Super Products LLC**

New Berlin, WI  
800-837-9711 • 262-784-710  
info@superproductsllc.com  
www.superproductsllc.com  
**Ad on page 25**



USB - Sewer Equipment Corporation

**USB - Sewer Equipment Corporation**

Marietta, GA  
866-408-2814 • 770-984-8880 • Fax: 770-984-2802  
info@usbsec.com  
www.usbsec.com  
**Ad on page 69**

**Vector Manufacturing**

Streator, IL  
800-627-3171 • 815-672-3171 • Fax: 815-672-2779  
sales@vector.com  
www.vector.com  
**Ad on page 3**

**VARCo**

Manassas, VA  
866-872-1224 • 703-334-5980 • Fax: 703-334-5979  
ron@varcopumper.com  
www.varcopumper.com

**Odor Control Products/ Equipment****ABS Materials, Inc.**

Wooster, OH  
330-234-7999  
info@absmaterials.com  
www.abswastewater.com  
**Ad on page 148**

**BioAir Solutions LLC**

Voorhees, NJ  
856-258-6969 • Fax: 856-258-6975  
cwest@bioairsolutions.com  
www.bioairsolutions.com

**Bionetix International**

Ste-Anne-de-Bellevue, QC  
Canada  
514-457-2914 • Fax: 514-457-3589  
info@bionetix.ca  
www.bionetix-international.com



**Chempace Corporation**

Toledo, OH  
800-423-5350 • 419-535-0101 • Fax: 419-535-0531  
vhorvath@chempace.com  
www.chempace.com

Ad on page 46

**Helix Laboratories, Inc.**

Corpus Christi, TX  
877-444-3549  
info@helixlabs.com  
www.helixlabs.com

Ad on page 63



**Indusco Environmental Services, Inc.**

Spanish Fort, AL  
251-621-2338  
sales@induscoenviro.com  
www.induscoenviro.com

Ad on page 146

**IPEX Inc.**

Oakville, ON  
Canada  
800-463-9572 • 289-881-0120 • Fax: 905-844-1504  
www.ipexamerica.com

Ad on page 125

**Jack Doheny Companies**

Northville, MI  
800-336-4369 • 248-349-0904 • Fax: 248-349-2774  
info@dohenycompanies.com  
www.dohenycompanies.com

**Parson Environmental Products, Inc.**

Reading, PA  
800-356-9023 • 610-582-6060 • Fax: 610-582-6064  
info@parsonenvironmental.com  
www.parsonenvironmental.com

Ad on page 109

**Pollardwater**

New Hyde Park, NY  
800-437-1146 • Fax: 516-746-0852  
info@pollardwater.com  
www.pollardwater.com

**Proco Products, Inc.**

Stockton, CA  
800-344-3246 • 209-943-6088 • Fax: 209-943-0242  
sales@procoproducts.com  
www.procoproducts.com

Ad on page 103

**Red Valve Co. / Tideflex Technologies**

Carnegie, PA  
412-279-0044 • Fax: 412-279-7878  
sales@redvalve.com  
www.redvalve.com

Ad on page 19

**Safe-Tee Chemical Company**

Scottsdale, AZ  
866-366-0587 • 480-968-6828 • Fax: 480-968-6776  
service@safetechechemical.com  
www.safetechechemical.com

Ad on page 145

**Simple Solutions Distributing LLC**

West Milford, NJ  
866-667-8465 • 973-846-7817 • Fax: 973-858-0219  
sales@industrialodorcontrol.com  
www.IndustrialOdorControl.com

Ad on page 145

**Superior Signal Company LLC**

Spotswood, NJ  
800-945-8378 • 732-251-0800 • Fax: 732-251-9442  
info@superiorsignal.com  
www.superiorsignal.com/msw

Ad on page 145

**Oil Spill Recovery/  
Clean-up**

**ABS Materials, Inc.**

Wooster, OH  
330-234-7999  
info@absmaterials.com  
www.abswastewater.com

Ad on page 148

**Bionetix International**

Ste-Anne-de-Bellevue, QC  
Canada  
514-457-2914 • Fax: 514-457-3589  
info@bionetix.ca  
www.bionetix-international.com

**Boerger, LLC**

Chanassen, MN  
612-435-7300 • Fax: 612-435-7301  
america@boerger.com  
www.boerger.com



**Eldred Environmental & Export Co. LTD**

Milan, IL  
800-613-3640 • 309-787-3640 • Fax: 309-787-3635  
info@fol-da-tank.com  
www.eldredenvironmental.com

**Helix Laboratories, Inc.**

Corpus Christi, TX  
877-444-3549  
info@helixlabs.com  
www.helixlabs.com

Ad on page 63

*ultra ultra ultra*  
**LIGHT – VERSATILE – SAFE**

**ultraSHORE**  
PRODUCTS

**Quick to Install.**  
As light as 130lbs.

**Roll Your Own.**  
Optional wheel kit.

**Stacks easily with**  
2' & 4' high panels.

**This is What Aluminum Shoring Was Meant to be!**

**1-800-SHORING**  
CALL TOLL-FREE NATIONWIDE • 1-800-746-7464  
**www.shoring.com**

1-800-683-8837

**GO NUTS**  
PIVOT HEAD VALVE KEYS

- Fits hard-to-reach 2" operating nuts.
- Heavy gauge, mechanical steel tubing shafts support a maximum torque of 200 foot-pounds.
- **Made in USA**, Reed valve keys feature strong welds at critical points.
- Use manually or with Reed's 700PD Power Drive and clutch.

**NEW**

Available in two lengths —  
VKP adjusts from 4 to 7 feet and  
VKP10 adjusts from 4 to 10 feet.

120 1896 2016  
AND BEYOND

PIPE TOOLS & VISES  
SINCE 1896

Reed Manufacturing Company  
Erie, PA USA • 800-666-3691 • reedsales@reedmfgco.com  
**www.reedmfgco.com**

VKP VKP10



**Milwaukee Rubber Products, Inc.**

Menomonee Falls, WI  
800-325-3730 • 262-781-7888 • Fax: 262-781-1742  
dennis@milwaukeeerubber.com  
www.milwaukeeerubber.com

**Ad on page 147**

**PK Safety**

Alameda, CA  
800-829-9580  
pks-store@pksafety.com  
www.pksafety.com

**Ad on page 148**

**Premier**

Fort Morgan, CO  
970-542-1975  
sales@poequip.com  
www.poequipment.com

**Safe-Tee Chemical Company**

Scottsdale, AZ  
866-366-0587 • 480-968-6828 • Fax: 480-968-6776  
service@safetechemical.com  
www.safetechemical.com

**Ad on page 145**

**Pipe - Concrete****Electro Scan Inc.**

Sacramento, CA  
800-975-6149 • 916-779-0660 • Fax: 916-779-0661  
info@electroscan.com  
www.electroscan.com

**Ad on page 153**

**Park Process**

Houston, TX  
855-511-7275 • 713-937-7602 • Fax: 713-937-4254  
rcaughman@parkprocess.com  
www.park-usa.com

**Ad on page 144**

**Thompson Pipe Group**

Rialto, CA  
909-822-0200  
info@thompsonpipegroup.com  
www.thompsonpipegroup.com

**Ad on page 46**

**Pipe - Fiberglass****Electro Scan Inc.**

Sacramento, CA  
800-975-6149 • 916-779-0660 • Fax: 916-779-0661  
info@electroscan.com  
www.electroscan.com

**Ad on page 153**

**Ferguson Waterworks**

Newport News, VA  
757-874-7795  
bryan.mokry@ferguson.com  
www.ferguson.com/waterworks

**Ad on page 49**

**Park Process**

Houston, TX  
855-511-7275 • 713-937-7602 • Fax: 713-937-4254  
rcaughman@parkprocess.com  
www.park-usa.com

**Ad on page 144**

**Reline America, Inc.**

Saltville, VA  
276-496-4000 • Fax: 276-496-4870  
info@relineamerica.com  
www.relineamerica.com

**Ad on page 11**

**SAERTEX-multiCom**

Huntersville, NC  
317-464-9717 • Fax: 704-464-5922  
m.hallett@saertex.com  
www.saertex-multicom.com

**Ad on page 75**

**SubSurface Instruments, Inc.**

De Pere, WI  
855-422-6346 • 920-347-1788 • Fax: 920-347-1791  
paul.renard@ssilocators.com  
www.ssilocators.com

**Ad on page 144**

**Thompson Pipe Group**

Rialto, CA  
909-822-0200  
info@thompsonpipegroup.com  
www.thompsonpipegroup.com

**Ad on page 46**

**Pipe - Polyethylene****Advanced Drainage Systems, Inc. - ADS**

Hilliard, OH  
800-773-7473  
www.ads-pipe.com

**Agru America, Inc.**

Georgetown, SC  
800-373-2478 • 843-546-0600 • Fax: 843-527-2738  
salesmkg@agruamerica.com  
www.agruamerica.com

**Ad on page 55**

**Electro Scan Inc.**

Sacramento, CA  
800-975-6149 • 916-779-0660 • Fax: 916-779-0661  
info@electroscan.com  
www.electroscan.com

**Ad on page 153**

**Ferguson Waterworks**

Newport News, VA  
757-874-7795  
bryan.mokry@ferguson.com  
www.ferguson.com/waterworks

**Ad on page 49**

**IPEX Inc.**

Oakville, ON  
Canada  
800-463-9572 • 289-881-0120 • Fax: 905-844-1504  
www.ipexamerica.com

**Ad on page 125**

**IPEX USA LLC**

Pineville, NC  
800-463-9572 • 704-889-2431 • Fax: 905-844-0826  
sales@ipexamerica.com  
www.enduragreaseamangement.com

**Lee Supply Company**

Charleroi, PA  
800-353-3747 • 724-483-3543 • Fax: 724-483-0577  
info@leesupply.com  
www.leesupply.com

**Ad on page 12**

**WL Plastics Corp.**

Fort Worth, TX  
682-831-2700 • Fax: 682-831-2710  
wlsales@wlplastics.com  
www.wlplastics.com

**Pipe - Polypropylene****Advanced Drainage Systems, Inc. - ADS**

Hilliard, OH  
800-773-7473  
www.ads-pipe.com

**Electro Scan Inc.**

Sacramento, CA  
800-975-6149 • 916-779-0660 • Fax: 916-779-0661  
info@electroscan.com  
www.electroscan.com

**Ad on page 153**

**Ferguson Waterworks**

Newport News, VA  
757-874-7795  
bryan.mokry@ferguson.com  
www.ferguson.com/waterworks

**Ad on page 49**

**Pipe - PVC****Electro Scan Inc.**

Sacramento, CA  
800-975-6149 • 916-779-0660 • Fax: 916-779-0661  
info@electroscan.com  
www.electroscan.com

**Ad on page 153**

**Ferguson Waterworks**

Newport News, VA  
757-874-7795  
bryan.mokry@ferguson.com  
www.ferguson.com/waterworks

**Ad on page 49**

**IPEX Inc.**

Oakville, ON  
Canada  
800-463-9572 • 289-881-0120 • Fax: 905-844-1504  
www.ipexamerica.com

**Ad on page 125**

**IPEX USA LLC**

Pineville, NC  
800-463-9572 • 704-889-2431 • Fax: 905-844-0826  
sales@ipexamerica.com  
www.enduragreaseamangement.com

**Lee Supply Company**

Charleroi, PA  
800-353-3747 • 724-483-3543 • Fax: 724-483-0577  
info@leesupply.com  
www.leesupply.com

**Ad on page 12**

**SubSurface Instruments, Inc.**

De Pere, WI  
855-422-6346 • 920-347-1788 • Fax: 920-347-1791  
paul.renard@ssilocators.com  
www.ssilocators.com

**Ad on page 144**

**Pipe - Steel****Ferguson Waterworks**

Newport News, VA  
757-874-7795  
bryan.mokry@ferguson.com  
www.ferguson.com/waterworks

**Ad on page 49**

**Lee Supply Company**

Charleroi, PA  
800-353-3747 • 724-483-3543 • Fax: 724-483-0577  
info@leesupply.com  
www.leesupply.com

**Ad on page 12**

**The Plug Hug**

Bellville, OH  
719-313-2791 • Fax: 419-525-2386  
douglasmarshall@theplughug.com  
www.theplughug.com

**Ad on page 145**

**Pipe - Supports**

**RELINER®  
Duran Inc.**

**RELINER/Duran Inc.**

Lyme, CT  
800-508-6001 • 860-434-0277 • Fax: 860-434-3195  
duran@reliner.com  
www.reliner.com

**Ad on page 38**

**Trumbull Industries, Inc.**

Youngstown, OH  
800-677-1799 • 330-799-3333 • Fax: 330-392-0756  
info-mfg@trumbull.com  
www.trumbull-mfg.com

**Ad on page 12**

**Pipe Bursting****Formadrain, Inc.**

Montreal, QC  
Canada  
888-337-6764  
info@formadrain.com  
www.formadrain.com

**Ad on page 135**

**HammerHead Trenchless Equipment**

Lake Mills, WI  
800-331-6653 • 920-648-4848  
jhaas@hammerheadmole.com  
www.hammerheadtrenchless.com

**Ad on page 45**

**Miller Pipeline**

Indianapolis, IN  
800-428-3742 • 317-293-0278  
www.millerpipeline.com

**Ad on page 71**





**Pow-r Mole Sales LLC**  
Lancaster, NY  
800-344-6653 • 716-683-2486 • Fax: 716-683-6372  
brian@powrmole.com  
www.powrmole.com

**Sunbelt Rentals**  
Fort Mill, SC  
800-736-2504  
www.sunbeltrentals.com  
Ad on page 139



**TRIC Tools, Inc.**  
Alameda, CA  
888-883-8742 • 510-629-4167 • Fax: 510-217-9493  
john.rafferty@trictools.com  
www.trictools.com

## Pipe Cutters

**Exact Pipe Tools**  
Cuyahoga Falls, OH  
844-392-2800 • 330-922-8150 • Fax: 888-607-9648  
nasales@exacttools.com  
www.exacttools.com

**Ferguson Waterworks**  
Newport News, VA  
757-874-7795  
bryan.mokry@ferguson.com  
www.ferguson.com/waterworks  
Ad on page 49

**ICS - Blount Inc.**  
Portland, OR  
800-321-1240 • Fax: 503-653-4393  
marketing@icsdiamondtools.com  
www.icsdiamondtools.com

**LMK Technologies**  
Ottawa, IL  
815-433-1275 • Fax: 815-433-0107  
info@lmktechnologies.com  
www.lmktechnologies.com  
Ad on page 143



**Pipeline Renewal Technologies**  
Randolph, NJ  
866-936-8476 • 973-252-6700 • Fax: 973-252-1176  
mail@pipelinert.com  
www.pipelinert.com  
Ad on page 37

**Reed Manufacturing Co.**  
Erie, PA  
800-666-3691 • 814-452-3691 • Fax: 814-455-1697  
reedsales@reedmfgco.com  
www.reedmfgco.com  
Ad on page 99

**RIDGID**  
Elyria, OH  
800-769-7743 • 440-323-5581 • Fax: 440-329-4862  
RIDGIDinfo@emerson.com  
www.RIDGID.com

## Pipe Fusion

**Ferguson Waterworks**  
Newport News, VA  
757-874-7795  
bryan.mokry@ferguson.com  
www.ferguson.com/waterworks  
Ad on page 49

**Lee Supply Company**  
Charleroi, PA  
800-353-3747 • 724-483-3543 • Fax: 724-483-0577  
info@leesupply.com  
www.leesupply.com  
Ad on page 12

**McElroy Manufacturing, Inc.**  
Tulsa, OK  
918-836-8611 • Fax: 918-831-9285  
smcelroy@mcelroy.com  
www.mcelroy.com

**PK Safety**  
Alameda, CA  
800-829-9580  
pks-store@pksafety.com  
www.pksafety.com  
Ad on page 148

**Pow-r Mole Sales LLC**  
Lancaster, NY  
800-344-6653 • 716-683-2486 • Fax: 716-683-6372  
brian@powrmole.com  
www.powrmole.com

**Sunbelt Rentals**  
Fort Mill, SC  
800-736-2504  
www.sunbeltrentals.com  
Ad on page 139

**Vanair Manufacturing**  
Michigan City, IN  
800-526-8817 • 219-879-5100 • Fax: 219-879-5800  
marketing@vanair.com  
www.vanair.com

# Stops Water Infiltration



**Infi-Shield® Gator Wrap** prevents infiltration and erosion by providing a water-tight seal around any manhole, catch basin or pipe joint. Infi-Shield® Gator Wrap resists harsh soil conditions and also provides a root barrier for any crack or joint.

The manhole chimney area is the number one source of infiltration in sanitary sewer collection systems. Preventing infiltration during the construction process is very cost effective and simple. **Infi-Shield® External Seal** is the best solution since it increases system capacity by preventing erosion and infiltration in both manholes and catch basins. The one piece molded seal is made from EPDM rubber and it has a reinforced preformed L-shaped corner.



**Sealing Systems, Inc.**  
800-478-2054  
www.ssisealingsystems.com



Convert Your Mobile Device into a HART Communicator ... with our Advanced HART-based Products

## Get HART® Data...On the Go!

CONNECT → CONFIGURE → DOCUMENT

**DevComDroid Communicator App**  
Full DD access to HART instruments using your Android device

**DevCom2000 Communicator Software**  
Full DD access to HART instruments using your Windows device

**HART Modems (Interface Hardware)**  
Bluetooth, USB and RS232 models



Call Us: 216.221.1550  
or toll free: 877.221.1551  
Fax: 216.221.1554  
Email: sales@procomsol.com





## Pipe Parts - Fittings & Components



### Advanced Drainage Systems, Inc. - ADS

Hilliard, OH  
800-773-7473  
www.ads-pipe.com

### Agru America, Inc.

Georgetown, SC  
800-373-2478 • 843-546-0600 • Fax: 843-527-2738  
salesmkg@agruamerica.com  
www.agruamerica.com

Ad on page 55

### IPEX USA LLC

Pineville, NC  
800-463-9572 • 704-889-2431 • Fax: 905-844-0826  
sales@ipexamerica.com  
www.enduragreaseamangement.com



Repair the past. Connect the future.

KRAUSZ is the creator of HYMAX.

### Krausz USA

Ocala, FL  
855-457-2879 • Fax: 352-304-5787  
mary.pfeiffer@krauszusa.com  
www.krauszusa.com

Ad on page 81

### Lee Supply Company

Charleroi, PA  
800-353-3747 • 724-483-3543 • Fax: 724-483-0577  
info@leesupply.com  
www.leesupply.com

Ad on page 12

### Proco Products, Inc.

Stockton, CA  
800-344-3246 • 209-943-6088 • Fax: 209-943-0242  
sales@procoproducts.com  
www.procoproducts.com

Ad on page 103

### RELINER/Duran Inc.

Lyme, CT  
800-508-6001 • 860-434-0277 • Fax: 860-434-3195  
duran@reliner.com  
www.reliner.com

Ad on page 38

### Sunbelt Rentals

Fort Mill, SC  
800-736-2504  
www.sunbeltrentals.com

Ad on page 139

### Thompson Pipe Group

Rialto, CA  
909-822-0200  
info@thompsonpipegroup.com  
www.thompsonpipegroup.com

Ad on page 46



### Total Piping Solutions, Inc.

Olean, NY  
716-372-0160 • Fax: 716-372-1767  
sales@tps.us  
www.tps.us

Ad on page 93

### VARCo

Manassas, VA  
866-872-1224 • 703-334-5980 • Fax: 703-334-5979  
ron@varcopumper.com  
www.varcopumper.com

## Pipe Plugs

### 3T Equipment Company Inc.

Santa Rosa, CA  
800-969-3001 • 707-543-8555 • Fax: 707-543-8558  
titequip@yahoo.com  
www.3tequipco.com

Ad on page 115

### Cloverleaf Tool Co.

Bradenton, FL  
800-365-6583 • 941-739-0707 • Fax: 941-739-0001  
sales@cloverleaftool.com  
www.cloverleaftool.com

Ad on page 115

### KEG Technologies, Inc.

Spartanburg, SC  
866-595-0515 • 864-804-6637 • Fax: 864-804-6629  
sales@kegtechnologies.net  
www.kegtechnologies.net

Ad on page 107



### Lansas Mfg. by Vanderlans & Sons Inc.

Lodi, CA  
800-452-4902 • 209-334-4115 • Fax: 209-339-8260  
sales@lansas.com  
www.lansas.com



### Logiball, Inc.

Quebec, QC  
Canada  
800-246-5988 • 418-656-9767 • Fax: 418-653-5746  
info@logiball.com  
www.logiball.com/en

### MTech

Cleveland, OH  
800-362-0240 • 440-646-0996 • Fax: 440-646-9953  
sales@mtechcompany.com  
www.mtechcompany.com

Ad on page 146

### Parson Environmental Products, Inc.

Reading, PA  
800-356-9023 • 610-582-6060 • Fax: 610-582-6064  
info@parsonenvironmental.com  
www.parsonenvironmental.com

Ad on page 109

### Petersen Products Co.

Fredonia, WI  
800-926-1926 • 262-692-2416 • Fax: 262-692-2418  
sales@petersenproducts.com  
www.petersenproducts.com

Ad on page 113

### Pronal-USA, Inc.

South Daytona, FL  
386-310-1558 • Fax: 386-310-1559  
tsimunar@pronal-usa.com  
www.pronal-usa.com

Ad on page 113



### Rental Tools Online

Sterling, VA  
866-952-8665 • Fax: 866-682-1525  
info@nationaltoolleasing.com  
www.RentalToolsOnline.com

Ad on page 32

### Sewer Equipment Co. of Florida, Inc.

New Smyrna Beach, FL  
800-635-2323 • 386-428-3303 • Fax: 386-427-4552  
csewerequipment@cfl.rr.com  
www.sewerequipmentco.com

Ad on page 147

### Sunbelt Rentals

Fort Mill, SC  
800-736-2504  
www.sunbeltrentals.com

Ad on page 139

### Trelleborg Pipe Seals Milford, Inc.

Milford, NH  
800-626-2180 • 603-673-8680 • Fax: 603-673-7271  
simon.burke@trelleborg.com  
www.trelleborg.com/pipe-seals

Ad on page 144

## Pipeline Rehabilitation/ Lining

### Agru America, Inc.

Georgetown, SC  
800-373-2478 • 843-546-0600 • Fax: 843-527-2738  
salesmkg@agruamerica.com  
www.agruamerica.com

Ad on page 55



### AP/M Permaform

Johnston, IA  
800-662-6465 • 515-276-9610 • Fax: 515-276-1274  
info@permaform.net  
www.permaform.net

Ad on page 67



### Aries Industries, Inc.

Waukesha, WI  
800-234-7205 • 262-896-7205  
sales@ariesindustries.com  
www.ariesindustries.com

Ad on page 123

### Avanti International

Houston, TX  
800-877-2570 • 281-486-5600 • Fax: 281-486-7300  
sales@avantigrout.com  
www.avantigrout.com

### CCI Pipeline Systems

Breaux Bridge, LA  
800-867-2772 • 337-332-5808 • Fax: 337-332-5809  
sales@ccipipe.com  
www.ccipipe.com

### Cortec Corporation

St. Paul, MN  
651-429-1100 • Fax: 651-429-1122  
info@cortecvci.com  
www.cortecvci.com

### CreteX Specialty Products

Waukesha, WI  
800-345-3764 • 262-542-8153 • Fax: 262-542-0301  
info@cretexseals.com  
www.cretexseals.com

Ad on page 24

### Duke's Root Control, Inc.

Syracuse, NY  
800-447-6687 • 315-472-4781 • Fax: 315-475-4203  
lynn@dukes.com  
www.dukes.com

Ad on page 13

### Electro Scan Inc.

Sacramento, CA  
800-975-6149 • 916-779-0660 • Fax: 916-779-0661  
info@electroscan.com  
www.electroscan.com

Ad on page 153

## THE SHOOTER®

### Emagineered Solutions, Inc.

Redmond, OR  
541-504-0416 • Fax: 541-504-0417  
ray.i@emagineered.com  
www.theshooterlipp.com

### Ferratex, Inc.

McKenney, VA  
804-451-3667 • Fax: 804-478-8296  
justing@ferratex.com  
www.ferratex.com

### Footage Tools, Inc.

Vaughan, ON  
Canada  
888-737-3668 • Fax: 905-695-8874  
bf@footage.ca  
www.footagetools.com

Ad on page 146



**Formadrain, Inc.**

Montreal, QC  
Canada  
888-337-6764  
info@formadrain.com  
www.formadrain.com  
**Ad on page 135**

**HammerHead Trenchless Equipment**

Lake Mills, WI  
800-331-6653 • 920-648-4848  
jhaas@hammerheadmole.com  
www.hammerheadtrenchless.com  
**Ad on page 45**

**HydraTech Engineered Products**

Cincinnati, OH  
513-827-9169 • Fax: 513-827-9171  
info@hydrattechllc.com  
www.hydrattechllc.com  
**Ad on page 145**

**Infrastructure Repair Systems Inc.**

St. Petersburg, FL  
877-327-4216 • Fax: 727-327-4118  
irsi@irsi.net  
www.irsi.net  
**Ad on page 46**

**IPEX Inc.**

Oakville, ON  
Canada  
800-463-9572 • 289-881-0120 • Fax: 905-844-1504  
www.ipexamerica.com  
**Ad on page 125**

**Lametti & Sons, Inc.**



Lametti & Sons  
Hugo, MN  
651-426-1380  
bretta@lametti.com  
www.lametti.com



Layne Inliner  
Orleans, IN  
812-865-3232  
heavycivilinfo@layne.com  
www.layne.com/inliner

**Light Ring Inc.**

McCallsburg, IA  
877-941-2833 • 515-290-8295 • Fax: 515-434-2249  
shane@lightringinc.com  
www.lightringinc.com  
**Ad on page 148**

**Linabond, Inc.**

Camarillo, CA  
805-484-7373  
info@linabond.com  
www.linabond.com

**LMK Technologies**

Ottawa, IL  
815-433-1275 • Fax: 815-433-0107  
info@lmktechnologies.com  
www.lmktechnologies.com  
**Ad on page 143**



**Logiball, Inc.**

Quebec, QC  
Canada  
800-246-5988 • 418-656-9767 • Fax: 418-653-5746  
info@logiball.com  
www.logiball.com/en

**Miller Pipeline**

Indianapolis, IN  
800-428-3742 • 317-293-0278  
www.millerpipeline.com  
**Ad on page 71**

**Neopoxy International, Inc.**

Hayward, CA  
510-782-1290 • Fax: 510-782-1292  
epoxy@neopoxy.us  
www.neopoxy.us  
**Ad on page 146**



**Perma-Liner Industries, LLC**

Clearwater, FL  
866-336-2568 • 727-507-9749 • Fax: 727-507-9849  
info@perma-liner.com  
www.perma-liner.com  
**Ad on page 5**

**Petersen Products Co.**

Fredonia, WI  
800-926-1926 • 262-692-2416 • Fax: 262-692-2418  
sales@petersenproducts.com  
www.petersenproducts.com  
**Ad on page 113**



**Pipeline Renewal Technologies**

Randolph, NJ  
866-936-8476 • 973-252-6700 • Fax: 973-252-1176  
mail@pipelinert.com  
www.pipelinert.com  
**Ad on page 37**

**Pow-r Mole Sales LLC**

Lancaster, NY  
800-344-6653 • 716-683-2486 • Fax: 716-683-6372  
brian@powrmole.com  
www.powrmole.com

# The Rudy Tool



RT1



Tip Detail

## Cover Remover

- Easily remove **Water Valve Box** and **Sewer Clean-out Box** Covers
- Eliminate the need for screw drivers
- Lifting handle creates gripping force
- Improved job safety and ergonomics
- Stand upright / Less bending
- Overall Length: 23.5"
- Bright color, easy to see

Call for a FREE catalog

**800.521.6893**

**T&T Tools, Inc.**

www.MightyProbe.com  
sales@mightyprobe.com

# The flow goes with PROCO.

Our unique rubber duckbill design prevents backflow.

The ProFlex® Series 700 Check Valves are a cost-effective, maintenance-free way to effectively prevent backflow from sewage treatment plants, outfalls and tidal operations. Our innovative design is corrosion, barnacle and algae resistant, too.



weftec 2016

BOOTH #3019



800-344-3246 | procoproducts.com  
The Expansion Joint and Check Valve People



**Prime Resins**

Conyers, GA  
800-321-7212 • 770-388-0626 • Fax: 770-388-0936  
info@primeresins.com  
www.primeresins.com

Ad on page 144

**rausch** USA

Rausch USA  
Chambersburg, PA  
877-728-7241 • 717-709-1005 • Fax: 717-709-1009  
reusa@rauschusa.com  
www.rauschusa.com

**RELIN**  
AMERICA

Reline America, Inc.  
Saltville, VA  
276-496-4000 • Fax: 276-496-4870  
info@relineamerica.com  
www.relineamerica.com  
Ad on page 11

**SAERTEX**  
multiCom

SAERTEX-multiCom  
Huntersville, NC  
317-464-9717 • Fax: 704-464-5922  
m.hallett@saertex.com  
www.saertex-multicom.com  
Ad on page 75

**Sauereisen, Inc.**

Pittsburgh, PA  
800-444-8235 • 412-963-0303 • Fax: 412-963-7620  
jedavis@sauereisen.com  
www.sauereisen.com  
Ad on page 38

**Sewer Equipment Co. of Florida, Inc.**

New Smyrna Beach, FL  
800-635-2323 • 386-428-3303 • Fax: 386-427-4552  
csewerekquipment@cfl.rr.com  
www.sewerekquipmentco.com  
Ad on page 147

**SIMPSON**  
Strong-Tie

**Simpson Strong-Tie Company, Inc.**

Pleasanton, CA  
800-925-5099 • Fax: 925-847-1603  
web@strongtie.com  
www.strongtie.com  
Ad on page 7

**Source One Environmental**

Davison, MI  
877-450-3701  
info@s1eonline.com  
www.s1eonline.com

**Sunbelt Rentals**

Fort Mill, SC  
800-736-2504  
www.sunbeltrentals.com  
Ad on page 139

**Superior Signal Company LLC**

Spotswood, NJ  
800-945-8378 • 732-251-0800 • Fax: 732-251-9442  
info@superiorsignal.com  
www.superiorsignal.com/msw  
Ad on page 145

THE  
**Strong Company**  
INC.

**The Strong Company, Inc.**

Pine Bluff, AR  
870-535-7617  
info@strongseal.com  
www.strongseal.com  
Ad on page 43

**Thompson Pipe Group**

Rialto, CA  
909-822-0200  
info@thompsonpipegroup.com  
www.thompsonpipegroup.com  
Ad on page 46

**Trelleborg Pipe Seals Milford, Inc.**

Milford, NH  
800-626-2180 • 603-673-8680 • Fax: 603-673-7271  
simon.burke@trelleborg.com  
www.trelleborg.com/pipe-seals  
Ad on page 144

**TRYTEK**  
MACHINE WORKS INC.

**TRY TEK Machine Works Inc.**

Jacobus, PA  
717-428-1477 • Fax: 717-428-2865  
trytek@trytek.com  
www.trytek.com

**Pipeline Stopping**

**HYDRA-STOP**

Hydra-Stop  
Burr Ridge, IL  
800-538-7867 • 708-389-5111 • Fax: 708-389-5125  
dchristensen@idexcorp.com  
www.hydra-stop.com

**Lansas Mfg. by Vanderlans & Sons Inc.**

Lodi, CA  
800-452-4902 • 209-334-4115 • Fax: 209-339-8260  
sales@lansas.com  
www.lansas.com

**Logiball**

Logiball, Inc.  
Quebec, QC  
Canada  
800-246-5988 • 418-656-9767 • Fax: 418-653-5746  
info@logiball.com  
www.logiball.com/en

**Petersen Products Co.**

Fredonia, WI  
800-926-1926 • 262-692-2416 • Fax: 262-692-2418  
sales@petersenproducts.com  
www.petersenproducts.com  
Ad on page 113

**Sewer Equipment Co. of Florida, Inc.**

New Smyrna Beach, FL  
800-635-2323 • 386-428-3303 • Fax: 386-427-4552  
csewerekquipment@cfl.rr.com  
www.sewerekquipmentco.com  
Ad on page 147

**TPS**

**Total Piping Solutions, Inc.**

Olean, NY  
716-372-0160 • Fax: 716-372-1767  
sales@tps.us  
www.tps.us  
Ad on page 93

**Pipeline Surveying & Mapping (GPS/GIS)**

**GraniteNet**  
ASBESTOS REMEDIATION SOLUTIONS SURVEYING AND TESTING

**CUES**

Orlando, FL  
800-327-7791 • 407-849-0190 • Fax: 407-425-1569  
salesinfo@cuesinc.com  
www.cuesinc.com  
Ad on page 15

**Electro Scan Inc.**

Sacramento, CA  
800-975-6149 • 916-779-0660 • Fax: 916-779-0661  
info@electroscan.com  
www.electroscan.com  
Ad on page 153

**Hurco Technologies, Inc.**

Harrisburg, SD  
800-888-1436 • 605-743-2466  
info@hurcotech.com  
www.hurcotech.com  
Ad on page 20

**JD7 Technologies**

San Diego, CA  
858-242-1640 • Fax: 858-242-1655  
info@jd7usa.com  
www.jd7usa.com

**Source One Environmental**

Davison, MI  
877-450-3701  
info@s1eonline.com  
www.s1eonline.com

**SubSurface Instruments, Inc.**

De Pere, WI  
855-422-6346 • 920-347-1788 • Fax: 920-347-1791  
paul.renard@ssillocators.com  
www.ssillocators.com  
Ad on page 144

**Trio Vision LLC dba Cobra Tech**

Smyrna, GA  
800-443-3761 • 770-435-8991 • Fax: 770-435-0402  
tomshchmandt@cobratec.com  
www.cobratec.com  
Ad on page 27

**VIVAX**  
METROTECH

**Vivax-Metrotech Corp.**

Santa Clara, CA  
800-446-3392 • 408-734-1400  
info@vxmt.com  
www.vivax-metrotech.com  
Ad on page 154

**Pipeline Tapping****Ferguson Waterworks**

Newport News, VA  
757-874-7795  
bryan.mokry@ferguson.com  
www.ferguson.com/waterworks  
Ad on page 49

**Footage Tools, Inc.**

Vaughan, ON  
Canada  
888-737-3668 • Fax: 905-695-8874  
bf@footage.ca  
www.footagetools.com  
Ad on page 146

**HYDRA-STOP**

Hydra-Stop  
Burr Ridge, IL  
800-538-7867 • 708-389-5111 • Fax: 708-389-5125  
dchristensen@idexcorp.com  
www.hydra-stop.com

**Mueller Co.**

Mueller Co.  
Chattanooga, TN  
800-423-1323 • 423-209-4800 • Fax: 423-209-4850  
moreinfo@muellercompany.com  
www.muellercompany.com

**Petersen Products Co.**

Fredonia, WI  
800-926-1926 • 262-692-2416 • Fax: 262-692-2418  
sales@petersenproducts.com  
www.petersenproducts.com  
Ad on page 113



**Reed Manufacturing Co.**

Erie, PA  
800-666-3691 • 814-452-3691 • Fax: 814-455-1697  
reedsales@reedmfgco.com  
www.reedmfgco.com

Ad on page 99



**Total Piping Solutions, Inc.**

Olean, NY  
716-372-0160 • Fax: 716-372-1767  
sales@tps.us  
www.tps.us

Ad on page 93

**Plant Maintenance & Rehabilitation**

**Environmental Coatings LLC**

Mesa, AZ  
480-984-7608 • Fax: 480-380-4461  
info@sewershield.com  
www.sewershield.com

**JPCI Services**

Mesa, AZ  
480-986-1212 • Fax: 480-380-4461  
info@jpciservices.com  
www.jpciservices.com

**Polyethylene Encasements**

**AA Thread Seal Tape, Inc.**

Wauconda, IL  
800-537-7139 • 847-526-2120 • Fax: 847-526-2209  
ryan@aathread.com  
www.aathread.com

Ad on page 148

**Positive Displacement Blowers**

**GapVax, Inc.**

Johnstown, PA  
888-442-7829 • 814-535-6766 • Fax: 814-539-3617  
inquiry@gapvax.com  
www.gapvax.com

Ad on page 135

**MTech**

Cleveland, OH  
800-362-0240 • 440-646-0996 • Fax: 440-646-9953  
sales@mtechcompany.com  
www.mtechcompany.com

Ad on page 146

**Superior Signal Company LLC**

Spotswood, NJ  
800-945-8378 • 732-251-0800 • Fax: 732-251-9442  
info@superiorsignal.com  
www.superiorsignal.com/msw

Ad on page 145

**Xceed Machine Works Inc.**  
Edmonton, AB  
Canada  
587-521-7544 • Fax: 587-521-8656  
forrester@xceedmachine.ca  
www.xceedmachine.ca  
Ad on page 20

**Pressure Testing Equipment**

**Giant Industries**

Toledo, OH  
800-633-4565 • 419-531-4600 • Fax: 419-531-6836  
sales@giantpumps.com  
www.giantpumps.com

**Lansas Mfg. by Vanderlans & Sons Inc.**

Lodi, CA  
800-452-4902 • 209-334-4115 • Fax: 209-339-8260  
sales@lansas.com  
www.lansas.com



**Logiball, Inc.**

Quebec, QC  
Canada  
800-246-5988 • 418-656-9767 • Fax: 418-653-5746  
info@logiball.com  
www.logiball.com/en

**NLB Corp.**

Wixom, MI  
800-227-7652 • 248-624-5555  
nlbmtg@nlbusa.com  
www.nlbcorp.com

**NozzTek, Inc.**

Clearwater, FL  
866-620-5915 • 727-223-4979 • Fax: 603-413-6744  
info@nozztek.com  
www.nozztek.com

Ad on page 105

**Triple R Specialty**

Jacksonville, FL  
800-356-9661 • Fax: 904-786-0911  
sales@triplerspecialty.com  
www.triplerspecialty.com

**Got Concrete?**

COME SEE US AT **WEO FAIR MILWAUKEE**

**Paikert®**

Hydro-Torque Impact Cutter that can remove hard deposits with strength of up to 5000 PSI. This is the go to cutter when all else fails.

Rentals Available

**Equipment Engineered for Long Lasting Performance™**

**CALL TODAY FOR AN ON-SITE DEMONSTRATION**  
Call For A FREE DVD

NAESCO Member

**NozzTek®**  
Taking Science to the Sewer!  
www.nozztek.com  
Toll Free 1.866.620.5915

- C-Ray 400™
- Orca™
- Manta™
- Paikert®
- BL Swiper™
- C-Ray 800™
- Jaws® 100
- Jaws®
- Lumberjack®
- Fir™
- Monro-Jet®
- Ice Bear™
- Lumberjack® 75 series
- Spinner™

**NOW AVAILABLE**

**VENTURO VC1000 VAN CRANE**

**VENTURO VAN CRANES**

The newest addition to the product lines include the all-new Venturo VC1000 Van Crane for the Ford Transit. This crane is revolutionary in the industry for its maximum weight capacity of 1,000 LBS and reach of 6 FT for the work van market.

**Max Capacity: 1,000 lbs @ 6 FT**  
**Crane Rating: 4,500 ft-lbs**  
**Power: Electric 12V DC**  
**Winch: 12V DC, 1.3 HP motor**  
**Wire Rope: 25 ft. of 3/16" aircraft-quality**

**VENCO VENTURO INDUSTRIES LLC**  
12110 Best Place | Cincinnati, Ohio 45241  
800-226-2238 | 513-772-8448  
info@venturo.com | www.venturo.com

**VENCO VENTURO INDUSTRIES LLC**



## Pressure Washers and Sprayers

### Cam Spray

Iowa Falls, IA  
800-648-5011 • 641-648-5011 • Fax: 641-648-5013  
sales@camspray.com  
www.camspray.com  
**Ad on page 38**

### Dultmeier Sales

Omaha, NE  
800-228-9666 • 402-333-1444 • Fax: 402-333-5546  
mhansen@dultmeier.com  
www.dultmeier.com

### Hot Jet USA

Riverton, UT  
800-624-8186 • 801-545-0777  
sales@powerlineindustries.com  
www.hotjetusa.com  
**Ad on page 147**

### NLB Corp.

Wixom, MI  
800-227-7652 • 248-624-5555  
nlbmtg@nlbusa.com  
www.nlbcorp.com

### NozzTeg, Inc.

Clearwater, FL  
866-620-5915 • 727-223-4979 • Fax: 603-413-6744  
info@nozzteg.com  
www.nozzteg.com  
**Ad on page 105**

### Root Rat

Bolivar, OH  
800-288-7873 • 330-874-4300 • Fax: 330-874-4448  
chempure@gmail.com  
www.rootrat.net  
**Ad on page 111**

### Sunbelt Rentals

Fort Mill, SC  
800-736-2504  
www.sunbeltrentals.com  
**Ad on page 139**

### Triple R Specialty

Jacksonville, FL  
800-356-9661 • Fax: 904-786-0911  
sales@triplerspecialty.com  
www.triplerspecialty.com

### Water Cannon, Inc. - MWBE

Lake Mary, FL  
800-333-9274 • 321-800-5763 • Fax: 888-928-9274  
sales@watercannon.com  
www.watercannon.com/catalogrequest.aspx  
**Ads on pages 119, 145**

## Pump Controls

### PRIMEX

Detroit Lakes, MN  
888-342-5753 • 218-847-1317 • Fax: 218-847-4617  
info@primexcontrols.com  
www.primexcontrols.com  
**Ad on page 56**

## Pump Parts/Components

### AMT Pump Company

Royersford, PA  
610-948-3800 • Fax: 610-948-5300  
sales@amtump.com  
www.amtump.com  
**Ad on page 83**

### Cloverleaf Tool Co.

Bradenton, FL  
800-365-6583 • 941-739-0707 • Fax: 941-739-0001  
sales@cloverleaftool.com  
www.cloverleaftool.com  
**Ad on page 115**



### Comet USA

Burnsville, MN  
800-708-1894 • 952-707-1894 • Fax: 952-707-1895  
cometpump@cometpump.com  
www.cometpump.com

### General Pump

Mendota Heights, MN  
888-474-5487 • 651-454-6500 • Fax: 651-454-8015  
sales@gpcompanies.com  
www.generalpump.com

### Giant Pumps

Toledo, OH  
800-633-4565 • 419-531-4600 • Fax: 419-531-6836  
sales@giantpumps.com  
www.giantpumps.com

### Hidrostral Pumps

Aurora, IL  
630-948-3355 • Fax: 630-948-3353  
info@hidrostralpumps.com  
www.hidrostralpumps.com

### Lee Supply Company

Charleroi, PA  
800-353-3747 • 724-483-3543 • Fax: 724-483-0577  
info@leesupply.com  
www.leesupply.com  
**Ad on page 12**

### NLB Corp.

Wixom, MI  
800-227-7652 • 248-624-5555  
nlbmtg@nlbusa.com  
www.nlbcorp.com

### Park Process

Houston, TX  
855-511-7275 • 713-937-7602 • Fax: 713-937-4254  
rcaughman@parkprocess.com  
www.park-usa.com  
**Ad on page 144**

### PRIMEX

Detroit Lakes, MN  
888-342-5753 • 218-847-1317 • Fax: 218-847-4617  
info@primexcontrols.com  
www.primexcontrols.com  
**Ad on page 56**

### Sewer Equipment Co. of Florida, Inc.

New Smyrna Beach, FL  
800-635-2323 • 386-428-3303 • Fax: 386-427-4552  
csewerequisite@cfllr.com  
www.sewerequisiteco.com  
**Ad on page 147**

### Smith & Loveless, Inc.

Lenexa, KS  
800-898-9122 • 913-888-5201  
answers@smithandloveless.com  
www.smithandloveless.com

### Vacuum Sales, Inc.

Lindenwold, NJ  
800-547-7790 • 856-627-7790 • Fax: 856-627-3044  
sales@vacuumsalesinc.com  
www.vacuumsalesinc.com

### VARCo

Manassas, VA  
866-872-1224 • 703-334-5980 • Fax: 703-334-5979  
ron@varcopumper.com  
www.varcopumper.com

## Pumps - Aeration

### Gorman-Rupp Company

Mansfield, OH  
419-755-1011 • Fax: 419-755-1251  
grsales@gormanrupp.com  
www.GRpumps.com

### Hidrostral Pumps

Aurora, IL  
630-948-3355 • Fax: 630-948-3353  
info@hidrostralpumps.com  
www.hidrostralpumps.com

### Red Valve Co. / Tideflex Technologies

Carnegie, PA  
412-279-0044 • Fax: 412-279-7878  
sales@redvalve.com  
www.redvalve.com  
**Ad on page 19**

### Xceed Machine Works Inc.

Edmonton, AB  
Canada  
587-521-7544 • Fax: 587-521-8656  
forrester@xceedmachine.ca  
www.xceedmachine.ca  
**Ad on page 20**

## Pumps - Centrifugal

### AMT Pump Company

Royersford, PA  
610-948-3800 • Fax: 610-948-5300  
sales@amtump.com  
www.amtump.com  
**Ad on page 83**

### Vaughan Company, Inc.

Montesano, WA  
888-249-2467 • 360-249-4042 • Fax: 360-249-6155  
info@chopperpumps.com  
www.chopperpumps.com  
**Ad on page 73**

### Vertiflo Pump Company

Cincinnati, OH  
513-530-0888 • Fax: 513-530-0893  
sales@vertiflopump.com  
www.vertiflopump.com  
**Ad on page 145**

## Pumps - Dewatering/ Bypass

### AMT Pump Company

Royersford, PA  
610-948-3800 • Fax: 610-948-5300  
sales@amtump.com  
www.amtump.com  
**Ad on page 83**

### Boerger, LLC

Chanhassen, MN  
612-435-7300 • Fax: 612-435-7301  
america@boerger.com  
www.boerger.com

### Clean Water Works Inc.

Ottawa, ON  
Canada  
866-695-0155 • 613-745-2444 • Fax: 613-745-9994  
kpeori@cwcanada.com  
www.cwcanada.com

### Ferguson Waterworks

Newport News, VA  
757-874-7795  
bryan.mokry@ferguson.com  
www.ferguson.com/waterworks  
**Ad on page 49**

### Gorman-Rupp Company

Mansfield, OH  
419-755-1011 • Fax: 419-755-1251  
grsales@gormanrupp.com  
www.GRpumps.com

### Pollardwater

New Hyde Park, NY  
800-437-1146 • Fax: 516-746-0852  
info@pollardwater.com  
www.pollardwater.com

### Sunbelt Rentals

Fort Mill, SC  
800-736-2504  
www.sunbeltrentals.com  
**Ad on page 139**

### Vaughan Company, Inc.

Montesano, WA  
888-249-2467 • 360-249-4042 • Fax: 360-249-6155  
info@chopperpumps.com  
www.chopperpumps.com  
**Ad on page 73**

### Vertiflo Pump Company

Cincinnati, OH  
513-530-0888 • Fax: 513-530-0893  
sales@vertiflopump.com  
www.vertiflopump.com  
**Ad on page 145**

### Xceed Machine Works Inc.

Edmonton, AB  
Canada  
587-521-7544 • Fax: 587-521-8656  
forrester@xceedmachine.ca  
www.xceedmachine.ca  
**Ad on page 20**



## Pumps - Effluent/ Sewage/Sump

### AMT Pump Company

Royersford, PA  
610-948-3800 • Fax: 610-948-5300  
sales@amtump.com  
www.amtump.com  
Ad on page 83

### Boerger, LLC

Chanhassen, MN  
612-435-7300 • Fax: 612-435-7301  
america@boerger.com  
www.boerger.com



### Comet USA

Burnsville, MN  
800-708-1894 • Fax: 952-707-1895  
cometpump@cometpump.com  
www.cometpump.com

### Dultmeier Sales

Omaha, NE  
800-228-9666 • Fax: 402-333-1444 • Fax: 402-333-5546  
mhansen@dultmeier.com  
www.dultmeier.com

### Ferguson Waterworks

Newport News, VA  
757-874-7795  
bryan.mokry@ferguson.com  
www.ferguson.com/waterworks  
Ad on page 49



### Gorman-Rupp Company

Mansfield, OH  
419-755-1011 • Fax: 419-755-1251  
grsales@gormanrupp.com  
www.GRpumps.com

### Hidrostal Pumps

Aurora, IL  
630-948-3355 • Fax: 630-948-3353  
info@hidrostalpumps.com  
www.hidrostalpumps.com

### Komline-Sanderson

Peapack, NJ  
800-225-5457 • Fax: 908-234-1000 • Fax: 908-234-9487  
info@komline.com  
www.komline.com  
Ad on page 65



### Liberty Pumps

Bergen, NY  
800-543-2550 • Fax: 585-494-1817 • Fax: 585-494-1839  
laurie.pfaff@libertypumps.com  
www.libertypumps.com

### Milwaukee Rubber Products, Inc.

Menomonee Falls, WI  
800-325-3730 • Fax: 262-781-7888 • Fax: 262-781-1742  
dennis@milwaukeeerubber.com  
www.milwaukeeerubber.com  
Ad on page 147

### Park Process

Houston, TX  
855-511-7275 • Fax: 713-937-7602 • Fax: 713-937-4254  
rcaughman@parkprocess.com  
www.park-usa.com  
Ad on page 144

### Red Valve Co. / Tideflex Technologies

Carnegie, PA  
412-279-0044 • Fax: 412-279-7878  
sales@redvalve.com  
www.redvalve.com  
Ad on page 19



### Smith & Loveless, Inc.

Lenexa, KS  
800-898-9122 • Fax: 913-888-5201  
answers@smithandloveless.com  
www.smithandloveless.com

### Vaughan Company, Inc.

Montesano, WA  
888-249-2467 • Fax: 360-249-4042 • Fax: 360-249-6155  
info@chopperpumps.com  
www.chopperpumps.com  
Ad on page 73

### Vertiflo Pump Company

Cincinnati, OH  
513-530-0888 • Fax: 513-530-0893  
sales@vertiflopump.com  
www.vertiflopump.com  
Ad on page 145

### Zoeller Company

Louisville, KY  
800-928-7867 • Fax: 502-778-2731  
www.zoeller.com

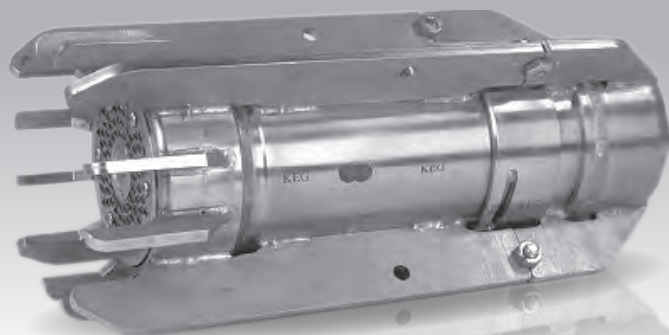

**KEG Technologies** has the first nozzle that cleans a pipe 360 degrees and records at the same time without any cables to get tangled – all in 1080p high-def!

**Turn on the Wi-Fi to upload your video to any smart phone, tablet or computer!**



www.kegtechnologies.net • 864.804.6637

## Stormwater Pollution Control

Captures 100% of Any Liquid Spill!



www.Hydro-Cartridge.com

### Hydro-Cartridge™

- Easy Installation
- Simple maintenance
- Retrofits any storm drain
- 35 year life span

Contact information:  
Advanced Aquatic Products  
International, Inc.  
1.800.738.7646  
www.Hydro-Cartridge.com

## Pumps - Grinder

### AMT Pump Company

Royersford, PA  
610-948-3800 • Fax: 610-948-5300  
sales@amtump.com  
www.amtump.com

Ad on page 83

### Ferguson Waterworks

Newport News, VA  
757-874-7795  
bryan.mokry@ferguson.com  
www.ferguson.com/waterworks

Ad on page 49

### Flygt - a Xylem Brand

Charlotte, NC  
855-995-4261  
www.xylem.com/pumping

### JWC Environmental

Santa Ana, CA  
800-331-2277 • 949-833-3888 • Fax: 714-428-4644  
jwce@jwce.com  
www.jwce.com

Ad on page 32

## Liberty Pumps

### Liberty Pumps

Bergen, NY  
800-543-2550 • 585-494-1817 • Fax: 585-494-1839  
laurie.pfaff@libertypumps.com  
www.libertypumps.com

### Pollardwater

New Hyde Park, NY  
800-437-1146 • Fax: 516-746-0852  
info@pollardwater.com  
www.pollardwater.com

### Vaughan Company, Inc.

Montesano, WA  
888-249-2467 • 360-249-4042 • Fax: 360-249-6155  
info@chopperpumps.com  
www.chopperpumps.com

Ad on page 73

### Xceed Machine Works Inc.

Edmonton, AB  
Canada  
587-521-7544 • Fax: 587-521-8656  
forrester@xceedmachine.ca  
www.xceedmachine.ca

Ad on page 20

### Zoeller Company

Louisville, KY  
800-928-7867 • 502-778-2731  
www.zoeller.com

## Pumps - High Pressure Water

### American Jetter

Knoxville, TN  
866-944-3569 • 865-524-4647 • Fax: 865-247-5105  
andy@americanjetter.com  
www.americanjetter.com

Ad on page 148

### AMT Pump Company

Royersford, PA  
610-948-3800 • Fax: 610-948-5300  
sales@amtump.com  
www.amtump.com

Ad on page 83

### Cloverleaf Tool Co.

Bradenton, FL  
800-365-6583 • 941-739-0707 • Fax: 941-739-0001  
sales@cloverleaftool.com  
www.cloverleaftool.com

Ad on page 115



### Comet USA

Burnsville, MN  
800-708-1894 • 952-707-1894 • Fax: 952-707-1895  
cometpump@cometpump.com  
www.cometpump.com

### Dultmeier Sales

Omaha, NE  
800-228-9666 • 402-333-1444 • Fax: 402-333-5546  
mhansen@dultmeier.com  
www.dultmeier.com

### GapVax, Inc.

Johnstown, PA  
888-442-7829 • 814-535-6766 • Fax: 814-539-3617  
inquiry@gapvax.com  
www.gapvax.com

Ad on page 155

### General Pump

Mendota Heights, MN  
888-474-5487 • 651-454-6500 • Fax: 651-454-8015  
sales@gpcompanies.com  
www.generalpump.com

### Giant Industries

Toledo, OH  
800-633-4565 • 419-531-4600 • Fax: 419-531-6836  
sales@giantpumps.com  
www.giantpumps.com

### Gorman-Rupp Company

Mansfield, OH  
419-755-1011 • Fax: 419-755-1251  
grsales@gormanrupp.com  
www.GRpumps.com

### Hammelmann Corp.

Dayton, OH  
800-783-4935 • 937-859-8777 • Fax: 937-859-9188  
mail@hammelmann.com  
www.hammelmann.com

### NLB Corp.

Wixom, MI  
800-227-7652 • 248-624-5555  
nlbmktg@nlbusa.com  
www.nlbcorp.com

### Root Rat

Bolivar, OH  
800-288-7873 • 330-874-4300 • Fax: 330-874-4448  
chempure@gmail.com  
www.rootrat.net

Ad on page 111

### Sonetics

Portland, OR  
877-959-9189 • 503-684-7080  
sales@soneticscorp.com  
www.soneticscorp.com/public-works

### Vacuum Sales, Inc.

Lindenwold, NJ  
800-547-7790 • 856-627-7790 • Fax: 856-627-3044  
sales@vacuumsalesinc.com  
www.vacuumsalesinc.com

### Water Cannon, Inc. - MWBE

Lake Mary, FL  
800-333-9274 • 321-800-5763 • Fax: 888-928-9274  
sales@watercannon.com  
www.watercannon.com/catalogrequest.aspx

Ad on pages 119, 145

## Pumps - Metering



### Blue-White Industries

Huntington Beach, CA  
714-893-8529 • Fax: 714-894-9492  
sales@blue-white.com  
www.blue-white.com

Ad on page 17

## Pumps - Solids/Sludge

### AMT Pump Company

Royersford, PA  
610-948-3800 • Fax: 610-948-5300  
sales@amtump.com  
www.amtump.com

Ad on page 83

### Vaughan Company, Inc.

Montesano, WA  
888-249-2467 • 360-249-4042 • Fax: 360-249-6155  
info@chopperpumps.com  
www.chopperpumps.com

Ad on page 73

### Vertiflo Pump Company

Cincinnati, OH  
513-530-0888 • Fax: 513-530-0893  
sales@vertiflopump.com  
www.vertiflopump.com

Ad on page 145

## Pumps - Stormwater

### AMT Pump Company

Royersford, PA  
610-948-3800 • Fax: 610-948-5300  
sales@amtump.com  
www.amtump.com

Ad on page 83



### Comet USA

Burnsville, MN  
800-708-1894 • 952-707-1894 • Fax: 952-707-1895  
cometpump@cometpump.com  
www.cometpump.com

### Ferguson Waterworks

Newport News, VA  
757-874-7795  
bryan.mokry@ferguson.com  
www.ferguson.com/waterworks

Ad on page 49

### Flygt - a Xylem Brand

Charlotte, NC  
855-995-4261  
www.xylem.com/pumping

### Gorman-Rupp Company

Mansfield, OH  
419-755-1011 • Fax: 419-755-1251  
grsales@gormanrupp.com  
www.GRpumps.com

### Hidrostral Pumps

Aurora, IL  
630-948-3355 • Fax: 630-948-3353  
info@hidrostralpumps.com  
www.hidrostralpumps.com

### Park Process

Houston, TX  
855-511-7275 • 713-937-7602 • Fax: 713-937-4254  
rcaughman@parkprocess.com  
www.park-usa.com

Ad on page 144

### PK Safety

Alameda, CA  
800-829-9580  
pks-store@pksafety.com  
www.pksafety.com

Ad on page 148

### Smith & Loveless, Inc.

Lenexa, KS  
800-898-9122 • 913-888-5201  
answers@smithandloveless.com  
www.smithandloveless.com

### Vaughan Company, Inc.

Montesano, WA  
888-249-2467 • 360-249-4042 • Fax: 360-249-6155  
info@chopperpumps.com  
www.chopperpumps.com

Ad on page 73

### Vertiflo Pump Company

Cincinnati, OH  
513-530-0888 • Fax: 513-530-0893  
sales@vertiflopump.com  
www.vertiflopump.com

Ad on page 145

### Xceed Machine Works Inc.

Edmonton, AB  
Canada  
587-521-7544 • Fax: 587-521-8656  
forrester@xceedmachine.ca  
www.xceedmachine.ca

Ad on page 20

## Pumps - Submersible

### Vaughan Company, Inc.

Montesano, WA  
888-249-2467 • 360-249-4042 • Fax: 360-249-6155  
info@chopperpumps.com  
www.chopperpumps.com

Ad on page 73

### Vertiflo Pump Company

Cincinnati, OH  
513-530-0888 • Fax: 513-530-0893  
sales@vertiflopump.com  
www.vertiflopump.com

Ad on page 145



## Pumps - Test



**Comet USA**  
Burnsville, MN  
800-708-1894 • 952-707-1894 • Fax: 952-707-1895  
cometpump@cometpump.com  
www.cometpump.com

**Hurco Technologies, Inc.**  
Harrisburg, SD  
800-888-1436 • 605-743-2466  
info@hurcotech.com  
www.hurcotech.com

Ad on page 20

**Reed Manufacturing Co.**  
Erie, PA  
800-666-3691 • 814-452-3691 • Fax: 814-455-1767  
reedsales@reedmfgco.com  
www.reedmfgco.com

Ad on page 99

## Pumps - Vacuum Pressure

**Cloverleaf Tool Co.**  
Bradenton, FL  
800-365-6583 • 941-739-0707 • Fax: 941-739-0001  
sales@cloverleaftool.com  
www.cloverleaftool.com

Ad on page 115

**Dultmeier Sales**  
Omaha, NE  
800-228-9666 • 402-333-1444 • Fax: 402-333-5546  
mhansen@dultmeier.com  
www.dultmeier.com

**Milwaukee Rubber Products, Inc.**  
Menomonee Falls, WI  
800-325-3730 • 262-781-7888 • Fax: 262-781-1742  
dennis@milwaukeerubber.com  
www.milwaukeerubber.com

Ad on page 147

**Sewer Equipment Co. of Florida, Inc.**  
New Smyrna Beach, FL  
800-635-2323 • 386-428-3303 • Fax: 386-427-4552  
csewerequipment@clr.com  
www.sewerequipmentco.com

Ad on page 147

**Vanair Manufacturing**  
Michigan City, IN  
800-526-8817 • 219-879-5100 • Fax: 219-879-5800  
marketing@vanair.com  
www.vanair.com

**VARCO**  
Manassas, VA  
866-872-1224 • 703-334-5980 • Fax: 703-334-5979  
ron@varcopumper.com  
www.varcopumper.com

**Xceed Machine Works Inc.**  
Edmonton, AB  
Canada  
587-521-7544 • Fax: 587-521-8656  
forrester@xceedmachine.ca  
www.xceedmachine.ca

Ad on page 20

## Pumps - Vertical/Lift Station

**Boerger, LLC**  
Chanhassen, MN  
612-435-7300 • Fax: 612-435-7301  
america@boerger.com  
www.boerger.com

**Flygt - a Xylem Brand**  
Charlotte, NC  
855-995-4261  
www.xylem.com/pumping

**Gorman-Rupp Company**  
Mansfield, OH  
419-755-1011 • Fax: 419-755-1251  
grsales@gormanrupp.com  
www.GRpumps.com



**Smith & Loveless, Inc.**  
Lenexa, KS  
800-898-9122 • 913-888-5201  
answers@smithandloveless.com  
www.smithandloveless.com

**Vaughan Company, Inc.**  
Montesano, WA  
888-249-2467 • 360-249-4042 • Fax: 360-249-6155  
info@chopperpumps.com  
www.chopperpumps.com

Ad on page 73

**Sto-Away Power Cranes**  
TAKE THE WORK, OUT OF WORK!<sup>SM</sup>  
The faster, safer, and more efficient way to get the job done!

A VERSATILE TOOL FOR MUNICIPALITIES AND SEWER PROFESSIONALS

Ask for the STO-AWAY POWER CRANES on your next bid

- CCTV Launching/Retrieval
- Confined Space Work
- Bulky Loads

Compliments of Best Equipment & Muncie Sanitary District

**Sto-Away Power Cranes, Inc.**  
9306 Grand Blvd. • Crown Point, IN 46307  
1.800.622.9797 • 219.942.9797 • www.stoaway.com

Certified WBENC



The Manhole Rehab Professionals Since 1985



- Products
- Equipment
- Tech Support
- Customer Service

Find out how our 30 years of experience can work for you.

800-356-9023  
www.parsonenvironmental.com

**Vertiflo Pump Company**

Cincinnati, OH  
513-530-0888 • Fax: 513-530-0893  
sales@vertiflopump.com  
www.vertiflopump.com

**Ad on page 145**

**Zoeller Company**

Louisville, KY  
800-928-7867 • 502-778-2731  
www.zoeller.com

**Pumps - Washdown****AMT Pump Company**

Royersford, PA  
610-948-3800 • Fax: 610-948-5300  
sales@amtump.com  
www.amtump.com

**Ad on page 83**

**Comet USA**

Burnsville, MN  
800-708-1894 • 952-707-1894 • Fax: 952-707-1895  
cometpump@cometpump.com  
www.cometpump.com

**Dultmeier Sales**

Omaha, NE  
800-228-9666 • 402-333-1444 • Fax: 402-333-5546  
mhansen@dultmeier.com  
www.dultmeier.com

**General Pump**

Mendota Heights, MN  
888-474-5487 • 651-454-6500 • Fax: 651-454-8015  
sales@gpcompanies.com  
www.generalpump.com

**Giant Industries**

Toledo, OH  
800-633-4565 • 419-531-4600 • Fax: 419-531-6836  
sales@giantpumps.com  
www.giantpumps.com

**Milwaukee Rubber Products, Inc.**

Menomonee Falls, WI  
800-325-3730 • 262-781-7888 • Fax: 262-781-1742  
dennis@milwaukeeerubber.com  
www.milwaukeeerubber.com

**Ad on page 147**

**Pumps - Water****AMT Pump Company**

Royersford, PA  
610-948-3800 • Fax: 610-948-5300  
sales@amtump.com  
www.amtump.com

**Ad on page 83**

**Boerger, LLC**

Chanhassen, MN  
612-435-7300 • Fax: 612-435-7301  
america@boerger.com  
www.boerger.com

**Comet USA**

Burnsville, MN  
800-708-1894 • 952-707-1894 • Fax: 952-707-1895  
cometpump@cometpump.com  
www.cometpump.com

**General Pump**

Mendota Heights, MN  
888-474-5487 • 651-454-6500 • Fax: 651-454-8015  
sales@gpcompanies.com  
www.generalpump.com

**Giant Industries**

Toledo, OH  
800-633-4565 • 419-531-4600 • Fax: 419-531-6836  
sales@giantpumps.com  
www.giantpumps.com

**Gorman-Rupp Company**

Mansfield, OH  
419-755-1011 • Fax: 419-755-1251  
grsales@gormanrupp.com  
www.GRpumps.com

**Hammelmann Corp.**

Dayton, OH  
800-783-4935 • 937-859-8777 • Fax: 937-859-9188  
mail@hammelmann.com  
www.hammelmann.com

**Lee Supply Company**

Charleroi, PA  
800-353-3747 • 724-483-3543 • Fax: 724-483-0577  
info@leesupply.com  
www.leesupply.com

**Ad on page 12**

**Milwaukee Rubber Products, Inc.**

Menomonee Falls, WI  
800-325-3730 • 262-781-7888 • Fax: 262-781-1742  
dennis@milwaukeeerubber.com  
www.milwaukeeerubber.com

**Ad on page 147**

**PK Safety**

Alameda, CA  
800-829-9580  
pks-store@pksafety.com  
www.pksafety.com

**Ad on page 148**

**Red Valve Co. / Tideflex Technologies**

Carnegie, PA  
412-279-0044 • Fax: 412-279-7878  
sales@redvalve.com  
www.redvalve.com

**Ad on page 19**

**Sunbelt Rentals**

Fort Mill, SC  
800-736-2504  
www.sunbeltrentals.com

**Ad on page 139**

**Vertiflo Pump Company**

Cincinnati, OH  
513-530-0888 • Fax: 513-530-0893  
sales@vertiflopump.com  
www.vertiflopump.com

**Ad on page 145**

**Xceed Machine Works Inc.**

Edmonton, AB  
Canada  
587-521-7544 • Fax: 587-521-8656  
forrester@xceedmachine.ca  
www.xceedmachine.ca

**Ad on page 20**

**Reinstatement Cutters****Aries Industries, Inc.**

Waukesha, WI  
800-234-7205 • 262-896-7205  
sales@ariesindustries.com  
www.ariesindustries.com

**Ad on page 123**

**CUES**

Orlando, FL  
800-327-7791 • 407-849-0190 • Fax: 407-425-1569  
salesinfo@cuesinc.com  
www.cuesinc.com

**Ad on page 15**

**Enz USA, Inc.**

Aurora, IL  
877-369-8721 • 630-692-7880 • Fax: 630-692-7885  
sales@enzusainc.com  
www.enzusainc.com

**Ad on page 77**

**Light Ring Inc.**

McCallsburg, IA  
877-941-2833 • 515-290-8295 • Fax: 515-434-2249  
shane@lightringinc.com  
www.lightringinc.com

**Ad on page 148**

**LMK Technologies**

Ottawa, IL  
815-433-1275 • Fax: 815-433-0107  
info@lmktechnologies.com  
www.lmktechnologies.com

**Ad on page 143**

**Perma-Liner Industries, LLC**

Clearwater, FL  
866-336-2568 • 727-507-9749 • Fax: 727-507-9849  
info@perma-liner.com  
www.perma-liner.com

**Ad on page 5**

**Pipeline Renewal Technologies**

Randolph, NJ  
866-936-8476 • 973-252-6700 • Fax: 973-252-1176  
mail@pipelinert.com  
www.pipelinert.com

**Ad on page 37**

**RapidView IBAK North America**

Rochester, IN  
800-656-4225 • 574-224-5426 • Fax: 574-223-7953  
info@rapidview.com  
www.rapidview.com

**Ad on page 131**

**Trelleborg Pipe Seals Milford, Inc.**

Milford, NH  
800-626-2180 • 603-673-8680 • Fax: 603-673-7271  
simon.burke@trelleborg.com  
www.trelleborg.com/pipe-seals

**Ad on page 144**

**TRY TEK Machine Works Inc.**

Jacobus, PA  
717-428-1477 • Fax: 717-428-2865  
trytek@trytek.com  
www.trytek.com

**Rental Equipment****ABS Materials, Inc.**

Wooster, OH  
330-234-7999  
info@absmaterials.com  
www.abswastewater.com

**Ad on page 148**

**American Shoring, Inc.**

Newburgh, NY  
800-407-4674 • 845-562-4477 • Fax: 800-361-1973  
ajhull@americanshoring.com  
www.americanshoring.com

**Ad on page 57**

**Aries Industries, Inc.**

Waukesha, WI  
800-234-7205 • 262-896-7205  
sales@ariesindustries.com  
www.ariesindustries.com

**Ad on page 123**

**Dynamic Repairs**

Lodi, NJ  
973-478-0893 • Fax: 973-478-0895  
dynamicablerepairs@yahoo.com  
www.dynamicrepairs.biz

**Ad on page 145**

**Environmental Rental Services LTD**

Rockdale, TX  
512-446-7011 • Fax: 512-446-7195  
sterling@ersvacrent.com  
www.ersvacrent.com

**Ad on page 148**

**Ferratex, Inc.**

McKenney, VA  
804-451-3667 • Fax: 804-478-8296  
justing@ferratex.com  
www.ferratex.com





**Jack Doheny Companies**  
Northville, MI  
800-336-4369 • 248-349-0904 • Fax: 248-349-2774  
info@dohenycompanies.com  
www.dohenycompanies.com



**Joe Johnson Equipment, Inc.**  
Innisfil, ON  
Canada  
800-263-1262 • 705-733-7700 • Fax: 707-733-8800  
info@jjei.com  
www.jjei.com

**KEG Technologies, Inc.**  
Spartanburg, SC  
866-595-0515 • 864-804-6637 • Fax: 864-804-6629  
sales@kegtechnologies.net  
www.kegtechnologies.net  
**Ad on page 107**

**KOHLER Power Systems**  
Kohler, WI  
800-544-2444 • 920-457-4441 • Fax: 920-459-1646  
generator.feedback@kohler.com  
www.kohlerpower.com

**Lansas Mfg. by Vanderlans & Sons Inc.**  
Lodi, CA  
800-452-4902 • 209-334-4115 • Fax: 209-339-8260  
sales@lansas.com  
www.lansas.com

**Light Ring Inc.**  
McCallsburg, IA  
877-941-2833 • 515-290-8295 • Fax: 515-434-2249  
shane@lightringinc.com  
www.lightringinc.com  
**Ad on page 148**

**Matchpoint Water Asset Management, Inc.**  
Wilmington, NC  
910-509-7225 • 910-509-7226  
info@matchpointinc.us  
www.matchpointinc.us  
**Ad on page 133**

**NLB Corp.**  
Wixom, MI  
800-227-7652 • 248-624-5555  
nlbmktg@nlbusa.com  
www.nlbcorp.com



**NozzTeq, Inc.**  
Clearwater, FL  
866-620-5915 • 727-223-4979 • Fax: 603-413-6744  
info@nozzteq.com  
www.nozzteq.com  
**Ad on page 105**

**Pow-r Mole Sales LLC**  
Lancaster, NY  
800-344-6653 • 716-683-2486 • Fax: 716-683-6372  
brian@powrmole.com  
www.powrmole.com



**R.S. Technical Services Inc.**  
Petaluma, CA  
800-767-1974 • 707-778-1974 • Fax: 707-778-1981  
sales.info@rstechserv.com  
www.rstechserv.com  
**Ad on page 31**

**Ratech Electronics, Ltd.**  
Concord, ON  
Canada  
800-461-9200 • 905-660-7072 • Fax: 905-660-1519  
sales@ratech-electronics.com  
www.ratech-electronics.com



**Reline America, Inc.**  
Salville, VA  
276-496-4000 • Fax: 276-496-4870  
info@relineamerica.com  
www.relineamerica.com  
**Ad on page 11**

**RTO**  
RENTAL TOOLS ONLINE  
**Rental Tools Online**  
Sterling, VA  
866-952-8665 • Fax: 866-682-1525  
info@nationaltoolleasing.com  
www.RentalToolsOnline.com  
**Ad on page 32**

**Resource West**  
Grand Junction, CO  
866-956-9378 • 970-245-7104 • Fax: 970-241-9942  
info@resourcewest.net  
www.resourcewest.net

**SAERTEX-multiCom**  
Huntersville, NC  
317-464-9717 • Fax: 704-464-5922  
m.hallett@saertex.com  
www.saertex-multicom.com  
**Ad on page 75**

**Sewer Equipment**  
Dixon, IL  
888-477-7611  
sales@sewerequipment.com  
www.sewerequipment.com  
**Ad on page 149**

**BARGE OFFERS SAFE WORK AREA AND BOOSTS CONFIDENCE For Work On Treatment Ponds and Lagoons.**

- > 8' x 12' platform
- > Approximate weight 550lbs
- > Approximate capacity 1400lbs
- > 23" Diameter aluminum pontoons - #5052 x .080 wall thickness
- > Heavy duty outboard motor mount for small gasoline or electric motors
- > Vinyl Decking for easy clean up
- > Heavy duty protective hand rail with ¼ rail spacers
- > Protective lower rail (keeps tools on board)
- > Safety chains
- > Welded Lifting eyes at each corner

**OPTIONS:**

- > Battery box with solar charger
- > Boarding ladder
- > 1000-lb. capacity crane
- > Galvanized trailer
- > Life ring
- > Pivot arms (Used to secure barge to aerator tubes when service is being performed on diffuser drop tubes.)

**AMERICAN PLEASURE PRODUCTS INC.**  
ROSE CITY, MI  
INFO@AQUACYCLEUSA.COM  
**989.685.2697**

**RAT OUT YOUR ROOT PROBLEMS**

Root Rat nozzles are uniquely designed to make short work of big sewer line headaches – chewing up roots and encrustations in all kinds of pipe. Interchangeable heads use the chain rotor for major obstructions and the cable rotor for less aggressive problems. Simplified service means extra uptime.

3/8", 1/2", 1" nozzles come in kit form.

**SEE IT IN ACTION**

Call 330.874.4300 to learn more about the nozzle you've been waiting for

**ROOT RAT NOZZLES**  
Patented • Made in USA • www.rootrat.net

**Sunbelt Rentals**

Fort Mill, SC  
800-736-2504  
www.sunbeltrentals.com  
Ad on page 139

**Super Products LLC**

New Berlin, WI  
800-837-9711 • 262-784-710  
info@superproductsllc.com  
www.superproductsllc.com  
Ad on page 25

**The Plug Hug**

Bellville, OH  
719-313-2791 • Fax: 419-525-2386  
douglassmarshall@theplughug.com  
www.theplughug.com  
Ad on page 145

**Trio Vision LLC dba Cobra Tech**

Smyrna, GA  
800-443-3761 • 770-435-8991 • Fax: 770-435-0402  
tomschmandr@cobratec.com  
www.cobratec.com  
Ad on page 27

**Vactor Manufacturing**

Streator, IL  
800-627-3171 • 815-672-3171 • Fax: 815-672-2779  
sales@vactor.com  
www.vactor.com  
Ad on page 3

**Vacuum Sales, Inc.**

Lindenwold, NJ  
800-547-7790 • 856-627-7790 • Fax: 856-627-3044  
sales@vacuumsalesinc.com  
www.vacuumsalesinc.com

**WesTech Engineering**

Salt Lake City, UT  
801-265-1000 • Fax: 801-265-1080  
info@westech-inc.com  
www.westech-inc.com

**Repair/Rebuilding Equipment****Dynamic Repairs**

Lodi, NJ  
973-478-0893 • Fax: 973-478-0895  
dynamiccablerepairs@yahoo.com  
www.dynamicrepairs.biz  
Ad on page 145

**Environmental Rental Services LTD**

Rockdale, TX  
512-446-7011 • Fax: 512-446-7195  
sterling@ersvacrent.com  
www.ersvacrent.com  
Ad on page 148

**Hidrostal Pumps**

Aurora, IL  
630-948-3355 • Fax: 630-948-3353  
info@hidrostalpumps.com  
www.hidrostalpumps.com

**Infrastructure Repair Systems Inc.**

St. Petersburg, FL  
877-327-4216 • Fax: 727-327-4118  
irsi@irsi.net  
www.irsi.net  
Ad on page 46

**Jack Doheny Companies**

Northville, MI  
800-336-4369 • 248-349-0904 • Fax: 248-349-2774  
info@dohenycompanies.com  
www.dohenycompanies.com

**NozzTeq, Inc.**

Clearwater, FL  
866-620-5915 • 727-223-4979 • Fax: 603-413-6744  
info@nozzteq.com  
www.nozzteq.com  
Ad on page 105

**The Plug Hug**

Bellville, OH  
719-313-2791 • Fax: 419-525-2386  
douglassmarshall@theplughug.com  
www.theplughug.com  
Ad on page 145

**Vactor Manufacturing**

Streator, IL  
800-627-3171 • 815-672-3171 • Fax: 815-672-2779  
sales@vactor.com  
www.vactor.com  
Ad on page 3

**Vacuum Sales, Inc.**

Lindenwold, NJ  
800-547-7790 • 856-627-7790 • Fax: 856-627-3044  
sales@vacuumsalesinc.com  
www.vacuumsalesinc.com

**Vanair Manufacturing**

Michigan City, IN  
800-526-8817 • 219-879-5100 • Fax: 219-879-5800  
marketing@vanair.com  
www.vanair.com

**Xceed Machine Works Inc.**

Edmonton, AB  
Canada  
587-521-7544 • Fax: 587-521-8656  
forrester@xceedmachine.ca  
www.xceedmachine.ca  
Ad on page 20

**Rodding Machines****General Pipe Cleaners**

McKees Rocks, PA  
800-245-6200 • 412-771-6300  
info@drainbrain.com  
www.drainbrain.com

**MTech**

Cleveland, OH  
800-362-0240 • 440-646-0996 • Fax: 440-646-9953  
sales@mtechcompany.com  
www.mtechcompany.com  
Ad on page 146

**RIDGID**

Elyria, OH  
800-769-7743 • 440-323-5581 • Fax: 440-329-4862  
RIDGIDinfo@emerson.com  
www.RIDGID.com

**Sewer Equipment**

Dixon, IL  
888-477-7611  
sales@sewerequipment.com  
www.sewerequipment.com  
Ad on page 149

**Sewer Equipment Co. of Florida, Inc.**

New Smyrna Beach, FL  
800-635-2323 • 386-428-3303 • Fax: 386-427-4552  
csewerequisite@cfllr.com  
www.sewerequisite.com  
Ad on page 147

**Sonetics**

Portland, OR  
877-959-9189 • 503-684-7080  
sales@soneticscorp.com  
www.soneticscorp.com/public-works

**Southland Tool Mfg. Inc.**

Anaheim, CA  
714-632-8198 • Fax: 714-632-8228  
sales@southlandtool.com  
www.southlandtool.com  
Ad on page 47

**Roll-Off Containers****Custom Manufacturing, Inc.**

Oklahoma City, OK  
888-692-6311 • 405-692-6311 • Fax: 405-691-8190  
jamie@custommanufacturing.us  
www.custommanufacturing.us

**Root Control - Chemical**

**DUKE'S**  
Product. Service. Guarantee.

**Duke's Root Control, Inc.**  
Syracuse, NY  
800-447-6687 • 315-472-4781 • Fax: 315-475-4203  
lynn@dukes.com  
www.dukes.com  
Ad on page 13

**RootX**

Salem, OR  
800-844-4974 • 503-364-2999 • Fax: 503-485-5229  
rootx@rootx.com  
www.rootx.com  
Ad on page 39

**Vaporooter**

Liberty, MO  
800-223-3684 • 816-781-4250 • Fax: 816-781-1043  
info@douglasproducts.com  
www.vaporooter.com  
Ad on page 137

**Root Control - Mechanical****American Jetter**

Knoxville, TN  
866-944-3569 • 865-524-4647 • Fax: 865-247-5105  
andy@americanjetter.com  
www.americanjetter.com  
Ad on page 148

**Arthur Products Co.**

Medina, OH  
800-322-0510 • 330-725-4905 • Fax: 330-722-2698  
apc@apdsq.com  
www.arthurproducts.com  
Ad on page 56

**Enz USA, Inc.**

Aurora, IL  
877-369-8721 • 630-692-7880 • Fax: 630-692-7885  
sales@enzusainc.com  
www.enzusainc.com  
Ad on page 77

**General Pipe Cleaners**

McKees Rocks, PA  
800-245-6200 • 412-771-6300  
info@drainbrain.com  
www.drainbrain.com

**KEG Technologies, Inc.**

Spartanburg, SC  
866-595-0515 • 864-804-6637 • Fax: 864-804-6629  
sales@kegtechnologies.net  
www.kegtechnologies.net  
Ad on page 107

**Logiball, Inc.**

Quebec, QC  
Canada  
800-246-5988 • 418-656-9767 • Fax: 418-653-5746  
info@logiball.com  
www.logiball.com/en

**MyTana Mfg. Company, Inc.**

St. Paul, MN  
800-328-8170 • 651-222-1738 • Fax: 651-222-1739  
mytana@mytana.com  
www.mytana.com  
Ad on page 12

**NozzTeq, Inc.**

Clearwater, FL  
866-620-5915 • 727-223-4979 • Fax: 603-413-6744  
info@nozzteq.com  
www.nozzteq.com  
Ad on page 105



**Perma-Liner Industries, LLC**

Clearwater, FL  
866-336-2568 • 727-507-9749 • Fax: 727-507-9849  
info@perma-liner.com  
www.perma-liner.com  
**Ad on page 5**

**RIDGID**

Elyria, OH  
800-769-7743 • 440-323-5581 • Fax: 440-329-4862  
RIDGIDinfo@emerson.com  
www.RIDGID.com

**Root Rat**

Bolivar, OH  
800-288-7873 • 330-874-4300 • Fax: 330-874-4448  
chempure@gmail.com  
www.rootrat.net  
**Ad on page 111**

**Sewer Equipment Co. of Florida, Inc.**

New Smyrna Beach, FL  
800-635-2323 • 386-428-3303 • Fax: 386-427-4552  
csewerequipment@cfl.rr.com  
www.sewerequipmentco.com  
**Ad on page 147**

**Southland Tool Mfg. Inc.**

Anaheim, CA  
714-632-8198 • Fax: 714-632-8228  
sales@southlandtool.com  
www.southlandtool.com  
**Ad on page 47**



USB - Sewer Equipment Corporation

**USB - Sewer Equipment Corporation**

Marietta, GA  
866-408-2814 • 770-984-8880 • Fax: 770-984-2802  
info@usbsec.com  
www.usbsec.com  
**Ad on page 69**

**Safety Equipment/  
Personal Protection  
Products**

**3T Equipment Company Inc.**

Santa Rosa, CA  
800-969-3001 • 707-543-8555 • Fax: 707-543-8558  
titequip@yahoo.com  
www.3tequipco.com  
**Ad on page 115**

**American Pleasure Products, Inc.**

Rose City, MI  
989-685-2697 • Fax: 989-685-8484  
info@aquacycleusa.com  
www.aquacycleusa.com  
**Ad on page 111**

**HEMCO Corporation**

Independence, MO  
800-779-4362 • 816-796-2900 • Fax: 816-796-3333  
info@hemcocorp.com  
www.hemcocorp.com  
**Ad on page 146**

**LIFTPLAQ US LLC**

Palmetto Bay, FL  
786-600-1843 • Fax: 855-220-2429  
llc@liftplaq.us  
www.liftplaq.us  
**Ad on page 147**

**Light Ring Inc.**

McCallsburg, IA  
877-941-2833 • 515-434-2248 • 515-290-8295  
www.lightringinc.com  
**Ad on page 148**

**Milwaukee Rubber Products, Inc.**

Menomonee Falls, WI  
800-325-3730 • 262-781-7888 • Fax: 262-781-1742  
dennis@milwaukeeerubber.com  
www.milwaukeeerubber.com  
**Ad on page 147**

**NLB Corp.**

Wixom, MI  
800-227-7652 • 248-624-5555  
nlbmkgt@nlbusa.com  
www.nlbcorp.com

**PK Safety**

Alameda, CA  
800-829-9580  
pks-store@pksafety.com  
www.pksafety.com  
**Ad on page 148**

**Plasticworks, Div of Lewis Plastics**

Addison, IL  
630-543-1750 • Fax: 630-543-4611  
chuck@plasticworks.com  
www.plasticworks.com  
**Ad on page 144**

**RKI Instruments, Inc.**

Union City, CA  
800-754-5165 • 510-441-5656  
orders@rkiinstruments.com  
www.rkiinstruments.com

**Sonetics**

Sonetics  
Portland, OR  
877-959-9189 • 503-684-7080  
sales@soneticscorp.com  
www.soneticscorp.com/public-works

**Southland Tool Mfg. Inc.**

Anaheim, CA  
714-632-8198 • Fax: 714-632-8228  
sales@southlandtool.com  
www.southlandtool.com  
**Ad on page 47**

**SMARTSHORE®  
INFLATABLE TRENCH SHIELD**



- REGISTERED PE CERTIFIED: OSHA compliant
- EASY TO HANDLE: each shield weighs only 28 lbs
- QUICK INSTALLATION: set up by two people in 10 minutes or less
- FOR DEPTHS UP TO 8 FEET
- MADE OF EXTREMELY TOUGH MATERIAL RESISTANT TO PUNCTURES
- EASY STORAGE

And more:

- > Tanks
- > Pipe Plugs
- > Back-fill Bladders

**PRONAL** USA, Inc.  
Elastomer Engineering

Tel: 386-310-1558  
info@pronal-usa.com  
www.pronal-usa.com

**Petersen® Pipe Plugging Systems**



Pipe Plugs and Packers for all your Pressure, Chemical, and Temperature Requirements. Call us to quickly customize a pipe plug or plugging system for your specific application.

**Economical Hot Tap  
Plugging Systems**

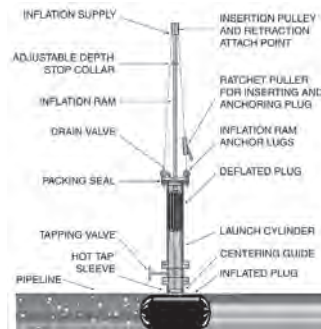

weftec 2016  
Booth 4301

www.pipeplug.com

**Petersen** PRODUCTS COMPANY  
Serving Professionals Since 1916

PHONE 800.769.4973 OR 262.692.2416  
FAX 800.669.1434 OR 262.692.2418

**Sto-Away Power Cranes, Inc.**

Crown Point, IN  
800-622-9797 • 219-942-9797 • Fax: 219-947-2503  
stoaway@comcast.net  
www.stoaway.com  
**Ad on page 109**

**Tech Products, Inc.**

Staten Island, NY  
800-221-1311 • 718-442-4900 • Fax: 718-442-2124  
thomas@techproducts.com  
www.techproducts.com

**The Plug Hug**

Bellville, OH  
719-313-2791 • Fax: 419-525-2386  
douglassmarsh@theplughug.com  
www.theplughug.com  
**Ad on page 145**

**TST Sweden AB**

SE-511 54 Kinna  
Sweden  
4-632-020-5880  
info@tst-sweden.com  
www.tst-sweden.com

**Sanitary Sewer  
Collection System****ADS LLC**

Huntsville, AL  
800-633-7246 • 256-430-3366 • Fax: 256-430-6633  
adsales@idexcorp.com  
www.adsenv.com  
**Ad on page 29**

**Advanced Drainage Systems, Inc. - ADS**

Hilliard, OH  
800-773-7473  
www.ads-pipe.com

**Aqua Operations, Inc.**

Bakersfield, CA  
888-746-6535 • 661-331-1181 • Fax: 661-833-1861  
operator@aquaooperations.com  
www.aquaooperations.com  
**Ad on page 146**

**Avantii International**

Houston, TX  
800-877-2570 • 281-486-5600 • Fax: 281-486-7300  
sales@avantigrout.com  
www.avantigrout.com

**Cretex Specialty Products**

Waukesha, WI  
800-345-3764 • 262-542-8153 • Fax: 262-542-0301  
info@cretexseals.com  
www.cretexseals.com  
**Ad on page 24**

**Flygt - a Xylem Brand**

Charlotte, NC  
855-995-4261  
www.xylem.com/pumping

**Hach - Flow Products & Services**

Loveland, CO  
800-368-2723  
www.hachflow.com

**InfoSense, Inc.**

Charlotte, NC  
877-747-3245 • 704-644-1164 • Fax: 704-930-0145  
achurchill@infosenseinc.com  
www.infosenseinc.com  
**Ad on page 95**

**JWC Environmental**

Santa Ana, CA  
800-331-2277 • 949-833-3888 • Fax: 714-428-4644  
jwce@jwce.com  
www.jwce.com  
**Ad on page 32**

**LMK Technologies**

Ottawa, IL  
815-433-1275 • Fax: 815-433-0107  
info@lmktechnologies.com  
www.lmktechnologies.com  
**Ad on page 143**

**Mr. Manhole**

Delphos, OH  
419-741-9075 • Fax: 419-692-1600  
sales@mrmanhole.com  
www.mrmanhole.com  
**Ad on page 55**

**Pollardwater**

New Hyde Park, NY  
800-437-1146 • Fax: 516-746-0852  
info@pollardwater.com  
www.pollardwater.com

**R.S. Technical Services Inc.**

Petaluma, CA  
800-767-1974 • 707-778-1974 • Fax: 707-778-1981  
sales.info@rstechserv.com  
www.rstechserv.com  
**Ad on page 31**

**RELINER/Duran Inc.**

Lyme, CT  
800-508-6001 • 860-434-0277 • Fax: 860-434-3195  
duran@reliner.com  
www.reliner.com  
**Ad on page 38**

**Sauereisen, Inc.**

Pittsburgh, PA  
800-444-8235 • 412-963-0303 • Fax: 412-963-7620  
jedavis@sauereisen.com  
www.sauereisen.com  
**Ad on page 38**

**Whirlygig, Inc.**

Caldwell, ID  
800-307-4263 • Fax: 208-454-2093  
info@wgig.us  
www.wgig.us

**SCADA Systems****Data Flow Systems, Inc.**

Melbourne, FL  
321-259-5009 • Fax: 321-259-4006  
www.dataflowsys.com  
**Ad on page 147**

**Flygt - a Xylem Brand**

Charlotte, NC  
855-995-4261  
www.xylem.com/pumping

**PRIMEX**

Detroit Lakes, MN  
888-342-5753 • 218-847-1317 • Fax: 218-847-4617  
info@primexcontrols.com  
www.primexcontrols.com  
**Ad on page 56**

**Screens - Wastewater****Aqualitec Corp.**

Los Angeles, CA  
855-650-2214  
info@aqualitec.com  
www.aqualitec.com

**Enviro-Care Company**

Gurnee, IL  
815-636-8306 • Fax: 847-672-7968  
ecsales@enviro-care.com  
www.enviro-care.com

**Hawk Measurement America**

Lawrence, MA  
888-429-5538 • 978-304-3000 • Fax: 978-304-1462  
info@hawkmeasure.com  
www.hawkmeasure.com

**JWC Environmental**

Santa Ana, CA  
800-331-2277 • 949-833-3888 • Fax: 714-428-4644  
jwce@jwce.com  
www.jwce.com  
**Ad on page 32**

**Smith & Loveless, Inc.**

Lenexa, KS  
800-898-9122 • 913-888-5201  
answers@smithandloveless.com  
www.smithandloveless.com

**WesTech Engineering**

Salt Lake City, UT  
801-265-1000 • Fax: 801-265-1080  
info@westech-inc.com  
www.westech-inc.com

**Security Equipment/  
Systems****Data Flow Systems, Inc.**

Melbourne, FL  
321-259-5009 • Fax: 321-259-4006  
www.dataflowsys.com  
**Ad on page 147**

**LIFTPLAQ US LLC**

Palmetto Bay, FL  
786-600-1843 • Fax: 855-220-2429  
llc@liftpla.us  
www.liftpla.us  
**Ad on page 147**

**McGard LLC**

Orchard Park, NY  
888-888-9192 • 716-662-8980 • Fax: 716-662-8985  
rglass@mcgard.com  
www.manholelocks.com  
**Ad on page 87**

**Plasticworks, Div of Lewis Plastics**

Addison, IL  
630-543-1750 • Fax: 630-543-4611  
chuck@plasticworks.com  
www.plasticworks.com  
**Ad on page 144**

**Tech Products, Inc.**

Staten Island, NY  
800-221-1311 • 718-442-4900 • Fax: 718-442-2124  
thomas@techproducts.com  
www.techproducts.com

**Septage Receiving  
Stations****Enviro-Care Company**

Gurnee, IL  
815-636-8306 • Fax: 847-672-7968  
ecsales@enviro-care.com  
www.enviro-care.com

**Service Company****Anthrifier U.S., Inc.**

Niagara Falls, NY  
800-998-8555 • 716-285-5680 • Fax: 716-285-5681  
swilley@anthrifier.net  
www.anthrifier.net  
**Ad on page 147**

**Dynamic Repairs**

Lodi, NJ  
973-478-0893 • Fax: 973-478-0895  
dynamicablerepairs@yahoo.com  
www.dynamicrepairs.biz  
**Ad on page 145**



**Electro Scan Inc.**

Sacramento, CA  
800-975-6149 • 916-779-0660 • Fax: 916-779-0661  
info@electroscan.com  
www.electroscan.com  
**Ad on page 153**

**Jack Doheny Companies**

Northville, MI  
800-336-4369 • 248-349-0904 • Fax: 248-349-2774  
info@dohenycompanies.com  
www.dohenycompanies.com

**JPCI Services**

Mesa, AZ  
480-986-1212 • Fax: 480-380-4461  
info@jpciservices.com  
www.jpciservices.com



**Reline America, Inc.**  
Salville, VA  
276-496-4000 • Fax: 276-496-4870  
info@relineamerica.com  
www.relineamerica.com  
**Ad on page 11**

**Shoring Equipment**



**American Shoring, Inc.**  
Newburgh, NY  
800-407-4674 • 845-562-4477 • Fax: 800-361-1973  
ajhull@americanshoring.com  
www.americanshoring.com  
**Ad on page 57**

**Efficiency Production, Inc.**

Mason, MI  
800-552-8800 • 517-676-8800 • Fax: 517-676-0373  
jmcra@efficiencyproduction.com  
www.efficiencyproduction.com  
**Ad on page 32**

**Pronal-USA, Inc.**

South Daytona, FL  
386-310-1558 • Fax: 386-310-1559  
tsimunac@pronal-usa.com  
www.pronal-usa.com  
**Ad on page 113**

**Sunbelt Rentals**

Fort Mill, SC  
800-736-2504  
www.sunbeltrentals.com  
**Ad on page 139**

**Ultra Shore**

Atlanta, GA  
800-746-7464 • 404-505-0510 • Fax: 404-505-0506  
info@shoring.com  
www.shoring.com  
**Ad on page 99**

**Signs/Labels/Tags**



**Tech Products, Inc.**  
Staten Island, NY  
800-221-1311 • 718-442-4900 • Fax: 718-442-2124  
thomas@techproducts.com  
www.techproducts.com

**Skimming Rake**

**Plasticworks, Div of Lewis Plastics**

Addison, IL  
630-543-1750 • Fax: 630-543-4611  
chuck@plasticworks.com  
www.plasticworks.com  
**Ad on page 144**

**Sludge - Treatment**

**Aqualitec Corp.**  
Los Angeles, CA  
855-650-2214  
info@aqualitec.com  
www.aqualitec.com

**Bionetix International**  
Ste-Anne-de-Bellevue, QC  
Canada  
514-457-2914 • Fax: 514-457-3589  
info@bionetix.ca  
www.bionetix-international.com

**Boerger, LLC**  
Chanhassen, MN  
612-435-7300 • Fax: 612-435-7301  
america@boerger.com  
www.boerger.com



**Enviro-Care Company**  
Gurnee, IL  
815-636-8306 • Fax: 847-672-7968  
ecsales@enviro-care.com  
www.enviro-care.com

**Flygt - a Xylem Brand**  
Charlotte, NC  
855-995-4261  
www.xylem.com/pumping



**PROWLER EASEMENT MACHINES**

The Prowler Easement Machine is available in extendable track, track, wheeled or track over wheel configurations. Reel available in capacities To 1,000 feet. Many options available. For more information contact:

3T Equipment Company Inc. **800-969-3001**

tttequip@yahoo.com, Web Site at www.3TEquipco.com

**Inside The Pipe "GRIPPER" Tool**



**Easy To Use Pneumatic Tool For Grabbing Objects in Sewers & Ventilation systems**

- Makes 90° Bend in 4" Pipe
- Air Powered (15psi) Operation up to 82' Standard or Longer Distances Possible (Option)
- Fast & Simple Maintenance
- "No" detection needed
- Camera Hook Up Optional
- Easy In/Out using Fiberglass Push Rods, Cable or Sectional Rods
- 2.16" dia. x 9.45" length - Weight 10#
- Pliers Teeth Grabbers Optional

**Cost \$2400.00 + Freight**

**CLOVERLEAF Tool Co.**

"Quality Products at Affordable Prices"  
P. O. Box 110757 • Bradenton, Florida 34211 USA  
**Toll Free: 800-365-6583**  
Tel: 941-739-0707 • Fax: 941-739-0001  
www.cloverleaftool.com • email: sales@cloverleaftool.com



**Municipal Sewer & Water**

*Socially Accepted*

facebook.com/MSWmag  
twitter.com/MSWmagazine  
plus.google.com  
youtube.com/MunicipalSewerWater  
linkedin.com/company/municipal-sewer-&-water-magazine

**Hawk Measurement America**

Lawrence, MA  
888-429-5538 • 978-304-3000 • Fax: 978-304-1462  
info@hawkmeasure.com  
www.hawkmeasure.com

**Helix Laboratories, Inc.**

Corpus Christi, TX  
877-444-3549  
info@helixlabs.com  
www.helixlabs.com

**Ad on page 63**

**Hidrostal Pumps**

Aurora, IL  
630-948-3355 • Fax: 630-948-3353  
info@hidrostalpumps.com  
www.hidrostalpumps.com

**JWC Environmental**

Santa Ana, CA  
800-331-2277 • 949-833-3888 • Fax: 714-428-4644  
jwce@jwce.com  
www.jwce.com

**Ad on page 32**

**Komline-Sanderson**

Peapack, NJ  
800-225-5457 • 908-234-1000 • Fax: 908-234-9487  
info@komline.com  
www.komline.com

**Ad on page 65**

**Red Valve Co. / Tideflex Technologies**

Carnegie, PA  
412-279-0044 • Fax: 412-279-7878  
sales@redvalve.com  
www.redvalve.com

**Ad on page 19**

**Smith & Loveless, Inc.**

Lenexa, KS  
800-898-9122 • 913-888-5201  
answers@smithandloveless.com  
www.smithandloveless.com

**WesTech Engineering**

Salt Lake City, UT  
801-265-1000 • Fax: 801-265-1080  
info@westech-inc.com  
www.westech-inc.com

**Software - Inspection/  
Mapping****ADS LLC**

Huntsville, AL  
800-633-7246 • 256-430-3366 • Fax: 256-430-6633  
adssales@idexcorp.com  
www.adsenv.com

**Ad on page 29**

**ARIES**  
INDUSTRIES, INC.

**Aries Industries, Inc.**

Waukesha, WI  
800-234-7205 • 262-896-7205  
sales@ariesindustries.com  
www.ariesindustries.com

**Ad on page 123**

**CUES**

Orlando, FL  
800-327-7791 • 407-849-0190 • Fax: 407-425-1569  
salesinfo@cuesinc.com  
www.cuesinc.com

**Ad on page 15**

**Envirosight**

Randolph, NJ  
866-936-8476 • 973-252-6700 • Fax: 973-252-1176  
mail@envirosight.com  
www.envirosight.com

**Ad on page 2**

**Famhost**

Wichita, KS  
800-658-1676 • 316-267-9910 • Fax: 800-858-2397  
info@famhoststaps.com  
www.famhost.com

**Ad on page 56**

**FlowWorks Inc.**

Seattle, WA  
206-859-6999 • Fax: 206-320-9939  
sales@flowworks.com  
www.flowworks.com

**Hurco Technologies, Inc.**

Harrisburg, SD  
800-888-1436 • 605-743-2466  
info@hurcotech.com  
www.hurcotech.com

**Ad on page 20**

**PipeLogix, Inc.**

Palm Desert, CA  
866-299-3150 • 760-779-1700 • Fax: 760-406-6023  
joan.stone@pipelogix.com  
www.pipelogix.com

**Ad on page 117**

**PipeTech Software**

Ada, MI  
800-262-7817 • 616-676-9811 • Fax: 616-676-9818  
sales@pipetech.tv  
www.pipetech.tv

**ProComSol, Ltd**

Lakewood, OH  
877-221-1551 • 216-221-1550 • Fax: 216-221-1554  
sales@procomsol.com  
www.procomsol.com

**Ad on page 101**

**R.S. Technical Services Inc.**

Petaluma, CA  
800-767-1974 • 707-778-1974 • Fax: 707-778-1981  
sales.info@rstechserv.com  
www.rstechserv.com

**Ad on page 31**

**Ratech Electronics, Ltd.**

Concord, ON  
Canada  
800-461-9200 • 905-660-7072 • Fax: 905-660-1519  
sales@ratech-electronics.com  
www.ratech-electronics.com

**Trio Vision LLC dba Cobra Tech**

Smyrna, GA  
800-443-3761 • 770-435-8991 • Fax: 770-435-0402  
tomschmandt@cobratec.com  
www.cobratec.com

**Ad on page 27**

**WinCan, LLC**

Pittsburgh, PA  
877-626-8386 • 412-489-6229  
sales.us@wincan.com  
www.wincan.com

**Ad on page 91**

**Sonar Profiling****CUES**

Orlando, FL  
800-327-7791 • 407-849-0190 • Fax: 407-425-1569  
salesinfo@cuesinc.com  
www.cuesinc.com

**Ad on page 15**

**R.S. Technical Services Inc.**

Petaluma, CA  
800-767-1974 • 707-778-1974 • Fax: 707-778-1981  
sales.info@rstechserv.com  
www.rstechserv.com

**Ad on page 31**

**Trio Vision LLC dba Cobra Tech**

Smyrna, GA  
800-443-3761 • 770-435-8991 • Fax: 770-435-0402  
tomschmandt@cobratec.com  
www.cobratec.com

**Ad on page 27**

**Storage Tanks****Clean Water Works Inc.**

Ottawa, ON  
Canada  
866-695-0155 • 613-745-2444 • Fax: 613-745-9994  
kpeori@cwvcanada.com  
www.cwvcanada.com

**Custom Manufacturing, Inc.**

Oklahoma City, OK  
888-692-6311 • 405-692-6311 • Fax: 405-691-8190  
jamie@custommanufacturing.us  
www.custommanufacturing.us

**Dultmeier Sales**

Omaha, NE  
800-228-9666 • 402-333-1444 • Fax: 402-333-5546  
mhansen@dultmeier.com  
www.dultmeier.com

**Eldred Environmental & Export Co. LTD**

Milan, IL  
800-613-3640 • 309-787-3640 • Fax: 309-787-3635  
info@fol-da-tank.com  
www.eldredenvironmental.com

**Park Process**

Houston, TX  
855-511-7275 • 713-937-7602 • Fax: 713-937-4254  
rcaughman@parkprocess.com  
www.park-usa.com

**Ad on page 144**

**PCI Manufacturing Solutions**

Sulphur Springs, TX  
800-256-5633 • 903-439-6999 • Fax: 903-885-7070  
marketing@pcimfgsolutions.com  
www.pcimfgsolutions.com

**Premier**

Fort Morgan, CO  
970-542-1975  
sales@poequip.com  
www.poequipment.com

**Pronal-USA, Inc.**

South Daytona, FL  
386-310-1558 • Fax: 386-310-1559  
tsimunac@pronal-usa.com  
www.pronal-usa.com

**Ad on page 113**

**Red Valve Co. / Tideflex Technologies**

Carnegie, PA  
412-279-0044 • Fax: 412-279-7878  
sales@redvalve.com  
www.redvalve.com

**Ad on page 19**



## Stormwater Collection Systems

### ABS Materials, Inc.

Wooster, OH  
330-234-7999  
info@absmaterials.com  
www.abswastewater.com

Ad on page 148

### Advanced Aquatic Products International, Inc.

Cutler Bay, FL  
800-738-7646 • 305-388-7195 • Fax: 305-388-7196  
advaquaticprods@aol.com  
www.hydro-cartridge.com

Ad on page 107



### Advanced Drainage Systems, Inc. - ADS

Hilliard, OH  
800-773-7473  
www.ads-pipe.com

### Avanti International

Houston, TX  
800-877-2570 • 281-486-5600 • Fax: 281-486-7300  
sales@avantigrout.com  
www.avantigrout.com

### CreteX Specialty Products

Waukesha, WI  
800-345-3764 • 262-542-8153 • Fax: 262-542-0301  
info@cretexseals.com  
www.cretexseals.com

Ad on page 24

### Enz USA, Inc.

Aurora, IL  
877-369-8721 • 630-692-7880 • Fax: 630-692-7885  
sales@enzusainc.com  
www.enzusainc.com

Ad on page 77

### Flygt - a Xylem Brand

Charlotte, NC  
855-995-4261  
www.xylem.com/pumping

### Hach - Flow Products & Services

Loveland, CO  
800-368-2723  
www.hachflow.com

### Linabond, Inc.

Camarillo, CA  
805-484-7373  
info@linabond.com  
www.linabond.com

### Mr. Manhole

Delphos, OH  
419-741-9075 • Fax: 419-692-1600  
sales@mrmanhole.com  
www.mrmanhole.com

Ad on page 55

### R.S. Technical Services Inc.

Petaluma, CA  
800-767-1974 • 707-778-1974 • Fax: 707-778-1981  
sales.info@rstechserv.com  
www.rstechserv.com

Ad on page 31

### Red Valve Co. / Tideflex Technologies

Carnegie, PA  
412-279-0044 • Fax: 412-279-7878  
sales@redvalve.com  
www.redvalve.com

Ad on page 19

**RELINE AMERICA**  
Reline America, Inc.  
Saltville, VA  
276-496-4000 • Fax: 276-496-4870  
info@relineamerica.com  
www.relineamerica.com  
Ad on page 11

### SAERTEX-multiCom

Huntersville, NC  
317-464-9717 • Fax: 704-464-5922  
m.hallett@saertex.com  
www.saertex-multicom.com

Ad on page 75

### Superior Signal Company LLC

Spotswood, NJ  
800-945-8378 • 732-251-0800 • Fax: 732-251-9442  
info@superiorsignal.com  
www.superiorsignal.com/msw

Ad on page 145



### Tech Products, Inc.

Staten Island, NY  
800-221-1311 • 718-442-4900 • Fax: 718-442-2124  
thomas@techproducts.com  
www.techproducts.com

### VEGA Americas, Inc.

Cincinnati, OH  
800-367-5383 • 513-272-0131 • Fax: 513-272-0133  
americas@vega.com  
www.vega.com

Ad on page 141

### Westech Engineering

Salt Lake City, UT  
801-265-1000 • Fax: 801-265-1080  
info@westech-inc.com  
www.westech-inc.com

### Whirllygig, Inc.

Caldwell, ID  
800-307-4263 • Fax: 208-454-2093  
info@wgig.us  
www.wgig.us

**the piece of the puzzle that completes the picture**

Whether your job is to capture data, map it, analyze it or share and collaborate findings across your organization, we can help. For over a decade, PipeLogix has been providing innovative solutions for infrastructure management that are backed by THE best after-sales support in the industry.

Call 866.299.3150 today to learn more or to schedule a FREE online demo of any of our survey solutions. [www.pipelogix.com](http://www.pipelogix.com)

Our Business Partners:

**GET EMAIL NEWS ALERTS FOR MUNICIPAL SEWER & WATER**

Go to [mswmag.com/alerts](http://mswmag.com/alerts) and get started today!

## Stormwater Management

### Abart Industries, LLC

Skaneateles, NY  
315-730-2588  
dave@tophatrisers.com  
www.tophatrisers.com

Ad on page 144

### ABS Materials, Inc.

Wooster, OH  
330-234-7999  
info@absmaterials.com  
www.abswastewater.com

Ad on page 148

### Advanced Aquatic Products International, Inc.

Cutler Bay, FL  
800-738-7646 • 305-388-7195 • Fax: 305-388-7196  
advaquaticprods@aol.com  
www.hydro-cartridge.com

Ad on page 107



### Advanced Drainage Systems, Inc. - ADS

Hilliard, OH  
800-773-7473  
www.ads-pipe.com

### Best Management Products, Inc.

Lyme, CT  
800-504-8008 • 410-687-6256 • Fax: 877-434-3197  
tjm@bmpinc.com  
www.bmpinc.com

Ad on page 24

### CHEMetrics, Inc.

Midland, VA  
800-356-3072 • 540-788-9026 • Fax: 540-788-4856  
sales@chemetrics.com  
www.chemetrics.com

### Data Flow Systems, Inc.

Melbourne, FL  
321-259-5009 • Fax: 321-259-4006  
www.dataflowsys.com

Ad on page 147

### Flygt - a Xylem Brand

Charlotte, NC  
855-995-4261  
www.xylem.com/pumping

### IPEX Inc.

Oakville, ON  
Canada  
800-463-9572 • 289-881-0120 • Fax: 905-844-1504  
www.ipexamerica.com

Ad on page 125



### LADTECH, Inc.

Lino Lakes, MN  
877-235-7464 • 651-415-1252 • Fax: 651-415-1090  
adjring@ladtech.com  
www.ladtech.com

Ad on page 85

### Proco Products, Inc.

Stockton, CA  
800-344-3246 • 209-943-6088 • Fax: 209-943-0242  
sales@procoproducts.com  
www.procoproducts.com

Ad on page 103

### Resource West

Grand Junction, CO  
866-956-9378 • 970-245-7104 • Fax: 970-241-9942  
info@resourcewest.net  
www.resourcewest.net

### SAERTEX-multiCom

Huntersville, NC  
317-464-9717 • Fax: 704-464-5922  
m.hallett@saertex.com  
www.saertex-multicom.com

Ad on page 75

### WesTech Engineering

Salt Lake City, UT  
801-265-1000 • Fax: 801-265-1080  
info@westech-inc.com  
www.westech-inc.com

## Stormwater Pretreatment

### ABS Materials, Inc.

Wooster, OH  
330-234-7999  
info@absmaterials.com  
www.abswastewater.com

Ad on page 148

### Advanced Aquatic Products International, Inc.

Cutler Bay, FL  
800-738-7646 • 305-388-7195 • Fax: 305-388-7196  
advaquaticprods@aol.com  
www.hydro-cartridge.com

Ad on page 107

### Best Management Products, Inc.

Lyme, CT  
800-504-8008 • 410-687-6256 • Fax: 877-434-3197  
tjm@bmpinc.com  
www.bmpinc.com

Ad on page 24

### CHEMetrics, Inc.

Midland, VA  
800-356-3072 • 540-788-9026 • Fax: 540-788-4856  
sales@chemetrics.com  
www.chemetrics.com

### Smith & Loveless, Inc.

Lenexa, KS  
800-898-9122 • 913-888-5201  
answers@smithandloveless.com  
www.smithandloveless.com

### WesTech Engineering

Salt Lake City, UT  
801-265-1000 • Fax: 801-265-1080  
info@westech-inc.com  
www.westech-inc.com

## Sweepers - Street

### Joe Johnson Equipment, Inc.

Innisfil, ON  
Canada  
800-263-1262 • 705-733-7700 • Fax: 707-733-8800  
info@jjei.com  
www.jjei.com

### MTEch

Cleveland, OH  
800-362-0240 • 440-646-0996 • Fax: 440-646-9953  
sales@mtechcompany.com  
www.mtechcompany.com

Ad on page 146



### Vacall - Gradall Industries

New Philadelphia, OH  
800-382-8302 • 330-339-2211 • Fax: 330-339-8468  
mtnorman@gradall.com  
www.vacall.com

Ad on page 33

## Tank Parts & Components

### Environmental Rental Services LTD

Rockdale, TX  
512-446-7011 • Fax: 512-446-7195  
sterling@ersvacrent.com  
www.ersvacrent.com

Ad on page 148

### WesTech Engineering

Salt Lake City, UT  
801-265-1000 • Fax: 801-265-1080  
info@westech-inc.com  
www.westech-inc.com

## Trade Show

### Informa Exhibitions

Irving, TX  
972-536-6477  
danny.green@informa.com  
www.informalexhibitions.com

Ad on page 59

## Trench Shielding

### Efficiency Production, Inc.

Mason, MI  
800-552-8800 • 517-676-8800 • Fax: 517-676-0373  
jmcra@efficiencyproduction.com  
www.efficiencyproduction.com

Ad on page 32

## Trenchless Pipe Replacement

### Agru America, Inc.

Georgetown, SC  
800-373-2478 • 843-546-0600 • Fax: 843-527-2738  
salesmkg@agruamerica.com  
www.agruamerica.com

Ad on page 55

### AP/M Permaform

Johnston, IA  
800-662-6465 • 515-276-9610 • Fax: 515-276-1274  
info@permaform.net  
www.permaform.net

Ad on page 67

### Ditch Witch

Perry, OK  
800-654-6481 • 580-336-4402  
info@ditchwitch.com  
www.ditchwitch.com

### Electro Scan Inc.

Sacramento, CA  
800-975-6149 • 916-779-0660 • Fax: 916-779-0661  
info@electroscan.com  
www.electroscan.com

Ad on page 153

### Footage Tools, Inc.

Vaughan, ON  
Canada  
888-737-3668 • Fax: 905-695-8874  
bf@footage.ca  
www.footagetools.com

Ad on page 146

### Formadrain, Inc.

Montreal, QC  
Canada  
888-337-6764  
info@formadrain.com  
www.formadrain.com

Ad on page 135

### HammerHead Trenchless Equipment

Lake Mills, WI  
800-331-6653 • 920-648-4848  
jhaas@hammerheadmole.com  
www.hammerheadtrenchless.com

Ad on page 45

### IPEX Inc.

Oakville, ON  
Canada  
800-463-9572 • 289-881-0120 • Fax: 905-844-1504  
www.ipexamerica.com

Ad on page 125

### LMK Technologies

Ottawa, IL  
815-433-1275 • Fax: 815-433-0107  
info@lmktechnologies.com  
www.lmktechnologies.com

Ad on page 143

### Miller Pipeline

Indianapolis, IN  
800-428-3742 • 317-293-0278  
www.millerpipeline.com

Ad on page 71



**PERMA-LINER INDUSTRIES, LLC.**  
**Perma-Liner Industries, LLC**  
 Clearwater, FL  
 866-336-2568 • 727-507-9749 • Fax: 727-507-9849  
 info@perma-liner.com  
 www.perma-liner.com  
**Ad on page 5**

**Pollardwater**  
 New Hyde Park, NY  
 800-437-1146 • Fax: 516-746-0852  
 info@pollardwater.com  
 www.pollardwater.com



**Pow-r Mole Sales LLC**  
 Lancaster, NY  
 800-344-6653 • 716-683-2486 • Fax: 716-683-6372  
 brian@powrmole.com  
 www.powrmole.com

**RELINER AMERICA**  
**Reline America, Inc.**  
 Saltville, VA  
 276-496-4000 • Fax: 276-496-4870  
 info@relineamerica.com  
 www.relineamerica.com  
**Ad on page 11**



**SAERTEX-multiCom**  
 Huntersville, NC  
 317-464-9717 • Fax: 704-464-5922  
 m.hallett@saertex.com  
 www.saertex-multicom.com  
**Ad on page 75**

**Thompson Pipe Group**  
 Rialto, CA  
 909-822-0200  
 info@thompsonpipegroup.com  
 www.thompsonpipegroup.com  
**Ad on page 46**

**TRY TEK Machine Works Inc.**  
 Jacobus, PA  
 717-428-1477 • Fax: 717-428-2865  
 trytek@trytek.com  
 www.trytek.com

**WL PLASTICS**  
 The Ideal Piping Solution  
**WL Plastics Corp.**  
 Fort Worth, TX  
 682-831-2700 • Fax: 682-831-2710  
 wlsales@wlplastics.com  
 www.wlplastics.com

**Trenchless Point/Spot Repair**

**Avanti International**  
 Houston, TX  
 800-877-2570 • 281-486-5600 • Fax: 281-486-7300  
 sales@avantigrout.com  
 www.avantigrout.com

**Clean Water Works Inc.**  
 Ottawa, ON  
 Canada  
 866-695-0155 • 613-745-2444 • Fax: 613-745-9994  
 kpeori@cwvcanada.com  
 www.cwvcanada.com

**Cretex Specialty Products**  
 Waukesha, WI  
 800-345-3764 • 262-542-8153 • Fax: 262-542-0301  
 info@cretexseals.com  
 www.cretexseals.com  
**Ad on page 24**

**HammerHead Trenchless Equipment**  
 Lake Mills, WI  
 800-331-6653 • 920-648-4848  
 jhaas@hammerheadmole.com  
 www.hammerheadtrenchless.com  
**Ad on page 45**

**HydraTech Engineered Products**  
 Cincinnati, OH  
 513-827-9169 • Fax: 513-827-9171  
 info@hydrattechllc.com  
 www.hydrattechllc.com  
**Ad on page 145**



**Infrastructure Repair Systems Inc.**  
 St. Petersburg, FL  
 877-327-4216 • Fax: 727-327-4118  
 irsi@irsi.net  
 www.irsi.net  
**Ad on page 46**

**Lansas Mfg. by Vanderlans & Sons Inc.**  
 Lodi, CA  
 800-452-4902 • 209-334-4115 • Fax: 209-339-8260  
 sales@lansas.com  
 www.lansas.com



**Pressure Washers, Replacement Engines, Pumps, Parts & Accessories**

**ACCESSORIES**

**JETTER KIT**



**\$49.99**

**HYDROEXCAVATION WANDS**



**ALL SIZES AND FLOWS**

**AIR RECOVERY SYSTEMS**



**\$499**

**UNDER CARRIAGE-CLEANER**



**\$499**

**WASHERS**

**HONDA 4300 PSI JETTER**



Base Model  
**\$1,199**

**\$1,499**

**5000 PSI & REEL**



**\$159.96**  
p/m  
36 months

**\$4,965**

**HOT WATER**



**\$122.78**  
p/m  
36 months

**\$3,899**

**DIESEL HOT WATER**



**\$238.78**  
p/m  
60 months

**7gpm @ 4000psi**



**WaterCannon.com**

**35**  
YEARS OF SERVICE

**1.800.333.WASH (9274)**

Water Cannon is proud to be a **MWBE**

**Linabond, Inc.**

Camarillo, CA  
805-484-7373  
info@linabond.com  
www.linabond.com

**LMK Technologies**

Ottawa, IL  
815-433-1275 • Fax: 815-433-0107  
info@lmktechnologies.com  
www.lmktechnologies.com  
Ad on page 143

**Logiball, Inc.**

Quebec, QC  
Canada  
800-246-5988 • 418-656-9767 • Fax: 418-653-5746  
info@logiball.com  
www.logiball.com/en

**Neopoxy International, Inc.**

Hayward, CA  
510-782-1290 • Fax: 510-782-1292  
epoxy@neopoxy.us  
www.neopoxy.us  
Ad on page 146

**Perma-Liner Industries, LLC**

Clearwater, FL  
866-336-2568 • 727-507-9749 • Fax: 727-507-9849  
info@perma-liner.com  
www.perma-liner.com  
Ad on page 5

**Pipeline Renewal Technologies**

Randolph, NJ  
866-936-8476 • 973-252-6700 • Fax: 973-252-1176  
mail@pipelinert.com  
www.pipelinert.com  
Ad on page 37

**Ratech Electronics, Ltd.**

Concord, ON  
Canada  
800-461-9200 • 905-660-7072 • Fax: 905-660-1519  
sales@ratech-electronics.com  
www.ratech-electronics.com

**Rausch USA**

Chambersburg, PA  
877-728-7241 • 717-709-1005 • Fax: 717-709-1009  
reusa@rauschusa.com  
www.rauschusa.com

**Reline America, Inc.**

Saltillo, VA  
276-496-4000 • Fax: 276-496-4870  
info@relineamerica.com  
www.relineamerica.com  
Ad on page 11

**SAERTEX-multiCom**

Huntersville, NC  
317-464-9717 • Fax: 704-464-5922  
m.hallett@saertex.com  
www.saertex-multi.com  
Ad on page 75

**Source One Environmental**

Davison, MI  
877-450-3701  
info@s1online.com  
www.s1online.com

**Trelleborg Pipe Seals Milford, Inc.**

Milford, NH  
800-626-2180 • 603-673-8680 • Fax: 603-673-7271  
simon.burke@trelleborg.com  
www.trelleborg.com/pipe-seals  
Ad on page 144

**Truck Parts/Accessories****Electro Scan Inc.**

Sacramento, CA  
800-975-6149 • 916-779-0660 • Fax: 916-779-0661  
info@electroscan.com  
www.electroscan.com  
Ad on page 153

**Hi-Vac Corporation**

Marietta, OH  
800-752-2400 • 740-374-2306 • Fax: 740-374-5447  
sales@x-vac.com  
www.x-vac.com  
Ad on page 151

**Super Products LLC**

New Berlin, WI  
800-837-9711 • 262-784-710  
info@superproductsllc.com  
www.superproductsllc.com  
Ad on page 25

**Underground Piercing Tools****Footage Tools, Inc.**

Vaughan, ON  
Canada  
888-737-3668 • Fax: 905-695-8874  
bf@footage.ca  
www.footagetools.com  
Ad on page 146

**HammerHead Trenchless Equipment**

Lake Mills, WI  
800-331-6653 • 920-648-4848  
jhaas@hammerheadmole.com  
www.hammerheadtrenchless.com  
Ad on page 45

**McLaughlin Group**

Greenville, SC  
800-435-9340 • 864-277-5870 • Fax: 864-235-9661  
mmole@mightymole.com  
www.mclaughlinunderground.com

**Pow-r Mole Sales LLC**

Lancaster, NY  
800-344-6653 • 716-683-2486 • Fax: 716-683-6372  
brian@powrmole.com  
www.powrmole.com

**Vanair Manufacturing**

Michigan City, IN  
800-526-8817 • 219-879-5100 • Fax: 219-879-5800  
marketing@vanair.com  
www.vanair.com

**UV CIPP****Aries Industries, Inc.**

Waukesha, WI  
800-234-7205 • 262-896-7205  
sales@ariesindustries.com  
www.ariesindustries.com  
Ad on page 123

**Vacuum Lifting****Hastings Irrigation Pipe Co.**

Hastings, NE  
800-759-8823 • Fax: 402-463-4355  
giones@hipco-ne.com  
www.hastingsirrigation.com

**Vacuum Tank Parts & Components****Milwaukee Rubber Products, Inc.**

Menomonee Falls, WI  
800-325-3730 • 262-781-7888 • Fax: 262-781-1742  
dennis@milwaukeeerubber.com  
www.milwaukeeerubber.com  
Ad on page 147

**Red Valve Co. / Tideflex Technologies**

Carnegie, PA  
412-279-0044 • Fax: 412-279-7878  
sales@redvalve.com  
www.redvalve.com  
Ad on page 19

**Vacuum Trucks - Water Recycling/Reuse****GapVax, Inc.**

Johnstown, PA  
888-442-7829 • 814-535-6766 • Fax: 814-539-3617  
inquiry@gapvax.com  
www.gapvax.com  
Ad on page 155

**J. Hvidtved Larsen US, Inc.**

Chicago, IL  
312-705-3818  
jhl@hvidtved.com  
www.hvidtved.com

**Super Products LLC**

New Berlin, WI  
800-837-9711 • 262-784-710  
info@superproductsllc.com  
www.superproductsllc.com  
Ad on page 25

**Vacall - Gradall Industries**

New Philadelphia, OH  
800-382-8302 • 330-339-2211 • Fax: 330-339-8468  
mtnorman@gradall.com  
www.vacall.com  
Ad on page 33

**Vector Manufacturing**

Streator, IL  
800-627-3171 • 815-672-3171 • Fax: 815-672-2779  
sales@vector.com  
www.vector.com  
Ad on page 3

**Vacuum Trucks/Trailers - Ind., Wet/dry, Non-Haz.****3T Equipment Company Inc.**

Santa Rosa, CA  
800-969-3001 • 707-543-8555 • Fax: 707-543-8558  
tthequip@yahoo.com  
www.3tequipco.com  
Ad on page 115

**Clean Water Works Inc.**

Ottawa, ON  
Canada  
866-695-0155 • 613-745-2444 • Fax: 613-745-9994  
kpeori@cwcanada.com  
www.cwcanada.com

**Ditch Witch**

Perry, OK  
800-654-6481 • 580-336-4402  
info@ditchwitch.com  
www.ditchwitch.com

**Environmental Rental Services LTD**

Rockdale, TX  
512-446-7011 • Fax: 512-446-7195  
sterling@ersvacrent.com  
www.ersvacrent.com  
Ad on page 148

**GapVax, Inc.**

Johnstown, PA  
888-442-7829 • 814-535-6766 • Fax: 814-539-3617  
inquiry@gapvax.com  
www.gapvax.com  
Ad on page 155

**Hastings Irrigation Pipe Co.**

Hastings, NE  
800-759-8823 • Fax: 402-463-4355  
giones@hipco-ne.com  
www.hastingsirrigation.com



**Hi-Vac Corporation**

Marietta, OH  
800-752-2400 • 740-374-2306 • Fax: 740-374-5447  
sales@x-vac.com  
www.x-vac.com

Ad on page 151

**J. Hvidtved Larsen US, Inc.**

Chicago, IL  
312-705-3818  
jhl@hvidtved.com  
www.hvidtved.com

**Jack Doheny Companies**

Northville, MI  
800-336-4369 • 248-349-0904 • Fax: 248-349-2774  
info@dohenycompanies.com  
www.dohenycompanies.com

**Joe Johnson Equipment, Inc.**

Innisfil, ON  
Canada  
800-263-1262 • 705-733-7700 • Fax: 707-733-8800  
info@jjei.com  
www.jjei.com

**Light Ring Inc.**

McCallsburg, IA  
877-941-2833 • 515-290-8295 • Fax: 515-434-2249  
shane@lightringinc.com  
www.lightringinc.com

Ad on page 148



**McLaughlin Group**

Greenville, SC  
800-435-9340 • 864-277-5870 • Fax: 864-235-9661  
mmole@mightymole.com  
www.mclaughlinunderground.com



**PCI Manufacturing Solutions**

Sulphur Springs, TX  
800-256-5633 • 903-439-6999 • Fax: 903-885-7070  
marketing@pcimfgsolutions.com  
www.pcimfgsolutions.com

**Premier**

Fort Morgan, CO  
970-542-1975  
sales@poequip.com  
www.poequipment.com

**Ring-O-Matic, Inc.**

Pella, IA  
800-544-2518 • 641-628-1515  
jzylstra@ring-o-matic.com  
www.ring-o-matic.com

**Sewer Equipment**

Dixon, IL  
888-477-7611  
sales@sewerequipment.com  
www.sewerequipment.com

Ad on page 149



**Super Products LLC**

New Berlin, WI  
800-837-9711 • 262-784-710  
info@superproductsllc.com  
www.superproductsllc.com

Ad on page 25



**Vac-Con, Inc.**

Green Cove Springs, FL  
904-284-4200 • Fax: 904-284-3305  
vns@vac-con.com  
www.vac-con.com

Ad on page 156

**Vac-Tron Equipment**

Okahumpka, FL  
352-728-2222  
kevin@vactron.com  
www.vactron.com

**Vacuum Sales, Inc.**

Lindenwold, NJ  
800-547-7790 • 856-627-7790 • Fax: 856-627-3044  
sales@vacuumsalesinc.com  
www.vacuumsalesinc.com

**Vacuum Trucks/Trailers - Septic**

**FlowMark Vacuum Trucks**

Kansas City, KS  
855-653-8100 • 913-653-8103 • Fax: 913-653-8101  
sales@flowmark.com  
www.flowmark.com

Ad on page 79

**Hastings Irrigation Pipe Co.**

Hastings, NE  
800-759-8823 • Fax: 402-463-4355  
gjones@hipco-ne.com  
www.hastingsirrigation.com

**Hi-Vac Corporation**

Marietta, OH  
800-752-2400 • 740-374-2306 • Fax: 740-374-5447  
sales@x-vac.com  
www.x-vac.com

Ad on page 151

**J. Hvidtved Larsen US, Inc.**

Chicago, IL  
312-705-3818  
jhl@hvidtved.com  
www.hvidtved.com



**PCI Manufacturing Solutions**

Sulphur Springs, TX  
800-256-5633 • 903-439-6999 • Fax: 903-885-7070  
marketing@pcimfgsolutions.com  
www.pcimfgsolutions.com

**Ring-O-Matic, Inc.**

Pella, IA  
800-544-2518 • 641-628-1515  
jzylstra@ring-o-matic.com  
www.ring-o-matic.com

**Vacuum Sales, Inc.**

Lindenwold, NJ  
800-547-7790 • 856-627-7790 • Fax: 856-627-3044  
sales@vacuumsalesinc.com  
www.vacuumsalesinc.com

**Vacuum Trucks/Trailers - Wet/Dry Hazardous**

**Clean Water Works Inc.**

Ottawa, ON  
Canada  
866-695-0155 • 613-745-2444 • Fax: 613-745-9994  
kpeori@cwwcanada.com  
www.cwwcanada.com

**Ditch Witch**

Perry, OK  
800-654-6481 • 580-336-4402  
info@ditchwitch.com  
www.ditchwitch.com

**Environmental Rental Services LTD**

Rockdale, TX  
512-446-7011 • Fax: 512-446-7195  
sterling@ersvacrent.com  
www.ersvacrent.com

Ad on page 148

**FlowMark Vacuum Trucks**

Kansas City, KS  
855-653-8100 • 913-653-8103 • Fax: 913-653-8101  
sales@flowmark.com  
www.flowmark.com

Ad on page 79

**Hastings Irrigation Pipe Co.**

Hastings, NE  
800-759-8823 • Fax: 402-463-4355  
gjones@hipco-ne.com  
www.hastingsirrigation.com

**Hi-Vac Corporation**

Marietta, OH  
800-752-2400 • 740-374-2306 • Fax: 740-374-5447  
sales@x-vac.com  
www.x-vac.com

Ad on page 151

**Jack Doheny Companies**

Northville, MI  
800-336-4369 • 248-349-0904 • Fax: 248-349-2774  
info@dohenycompanies.com  
www.dohenycompanies.com



**PCI Manufacturing Solutions**

Sulphur Springs, TX  
800-256-5633 • 903-439-6999 • Fax: 903-885-7070  
marketing@pcimfgsolutions.com  
www.pcimfgsolutions.com



**Super Products LLC**

New Berlin, WI  
800-837-9711 • 262-784-710  
info@superproductsllc.com  
www.superproductsllc.com

Ad on page 25

**Vac-Tron Equipment**

Okahumpka, FL  
352-728-2222  
kevin@vactron.com  
www.vactron.com

**Vacuum Sales, Inc.**

Lindenwold, NJ  
800-547-7790 • 856-627-7790 • Fax: 856-627-3044  
sales@vacuumsalesinc.com  
www.vacuumsalesinc.com

**Vanair Manufacturing**

Michigan City, IN  
800-526-8817 • 219-879-5100 • Fax: 219-879-5800  
marketing@vanair.com  
www.vanair.com

**Valve Boxes/ Components**

**Lee Supply Company**

Charleroi, PA  
800-353-3747 • 724-483-3543 • Fax: 724-483-0577  
info@leesupply.com  
www.leesupply.com

Ad on page 12

**Mr. Manhole**

Delphos, OH  
419-741-9075 • Fax: 419-692-1600  
sales@mrmanhole.com  
www.mrmanhole.com

Ad on page 55



**Mueller Co.**

Chattanooga, TN  
800-423-1323 • 423-209-4800 • Fax: 423-209-4850  
moreinfo@muellercompany.com  
www.muellercompany.com

**Specialty Maintenance Products, Inc.**

Houston, TX  
713-667-4402 • Fax: 713-669-8618  
sales@smptools.com  
www.smptools.com

Ad on page 89

**Valve Exercising Equipment**

**3T Equipment Company Inc.**

Santa Rosa, CA  
800-969-3001 • 707-543-8555 • Fax: 707-543-8558  
tfequip@yahoo.com  
www.3tequipco.com

Ad on page 115

**Ditch Witch**

Perry, OK  
800-654-6481 • 580-336-4402  
info@ditchwitch.com  
www.ditchwitch.com

**Hurco Technologies, Inc.**

Harrisburg, SD  
800-888-1436 • 605-743-2466  
info@hurcotech.com  
www.hurcotech.com

Ad on page 20

**McLaughlin Group**

Greenville, SC  
800-435-9340 • 864-277-5870 • Fax: 864-235-9661  
mmole@mightymole.com  
www.mclaughlinunderground.com

**Reed Manufacturing Co.**

Erie, PA  
800-666-3691 • 814-452-3691 • Fax: 814-455-1697  
reedsales@reedmfgco.com  
www.reedmfgco.com  
**Ad on page 99**

**Specialty Maintenance Products, Inc.**

Houston, TX  
713-667-4402 • Fax: 713-669-8618  
sales@smptools.com  
www.smptools.com  
**Ad on page 89**

**Valve Insertion/  
Removal Tools****HYDRA-STOP®**

Hydra-Stop  
Burr Ridge, IL  
800-538-7867 • 708-389-5111 • Fax: 708-389-5125  
dchristensen@idexcorp.com  
www.hydra-stop.com

**Mr. Manhole**

Delphos, OH  
419-741-9075 • Fax: 419-692-1600  
sales@mrmmanhole.com  
www.mrmmanhole.com  
**Ad on page 55**

**Reed Manufacturing Co.**

Erie, PA  
800-666-3691 • 814-452-3691 • Fax: 814-455-1697  
reedsales@reedmfgco.com  
www.reedmfgco.com  
**Ad on page 99**

**Specialty Maintenance Products, Inc.**

Houston, TX  
713-667-4402 • Fax: 713-669-8618  
sales@smptools.com  
www.smptools.com  
**Ad on page 89**

**Valves****Dultmeier Sales**

Omaha, NE  
800-228-9666 • 402-333-1444 • Fax: 402-333-5546  
mhansen@dultmeier.com  
www.dultmeier.com

**Ferguson Waterworks**

Newport News, VA  
757-874-7795  
bryan.mokry@ferguson.com  
www.ferguson.com/waterworks  
**Ad on page 49**

**General Pump**

Mendota Heights, MN  
888-474-5487 • 651-454-6500 • Fax: 651-454-8015  
sales@gpccompanies.com  
www.generalpump.com

**Giant Industries**

Toledo, OH  
800-633-4565 • 419-531-4600 • Fax: 419-531-6836  
sales@giantpumps.com  
www.giantpumps.com

**HARCO Fittings**

Lynchburg, VA  
434-845-7094 • Fax: 434-845-8562  
sales@harcofittings.com  
www.harcofittings.com  
**Ad on page 148**

**IPEX Inc.**

Oakville, ON  
Canada  
800-463-9572 • 289-881-0120 • Fax: 905-844-1504  
www.ipexamerica.com  
**Ad on page 125**

**Mueller Co.**

Chattanooga, TN  
800-423-1323 • 423-209-4800 • Fax: 423-209-4850  
moreinfo@muellercompany.com  
www.muellercompany.com

**Proco Products, Inc.**

Stockton, CA  
800-344-3246 • 209-943-6088 • Fax: 209-943-0242  
sales@procoproducts.com  
www.procoproducts.com  
**Ad on page 103**

**Red Valve Co. / Tideflex Technologies**

Carnegie, PA  
412-279-0044 • Fax: 412-279-7878  
sales@redvalve.com  
www.redvalve.com  
**Ad on page 19**

**Sierra Instruments, Inc.**

Monterey, CA  
800-866-0200 • 831-373-0200 • Fax: 831-373-4402  
info@sierrainstruments.com  
www.sierrainstruments.com

**Singer Valve Inc.**

Surrey, BC  
Canada  
888-764-7858 • 604-594-5404 • Fax: 604-594-8845  
singer@singervalve.com  
www.singervalve.com

**Specialty Maintenance Products, Inc.**

Houston, TX  
713-667-4402 • Fax: 713-669-8618  
sales@smptools.com  
www.smptools.com  
**Ad on page 89**

**Sunbelt Rentals**

Fort Mill, SC  
800-736-2504  
www.sunbeltrentals.com  
**Ad on page 139**

**The Plug Hug**

Bellville, OH  
719-313-2791 • Fax: 419-525-2386  
douglassmarshall@theplughug.com  
www.theplughug.com  
**Ad on page 145**

**Trumbull Industries, Inc.**

Youngstown, OH  
800-677-1799 • 330-799-3333 • Fax: 330-392-0756  
info-mfg@trumbull.com  
www.trumbull-mfg.com  
**Ad on page 12**

**Zoeller Company**

Louisville, KY  
800-928-7867 • 502-778-2731  
www.zoeller.com

**Vent Pipe Filters****Simple Solutions Distributing LLC**

West Milford, NJ  
866-667-8465 • 973-846-7817 • Fax: 973-858-0219  
sales@industrialodorcontrol.com  
www.IndustrialOdorControl.com  
**Ad on page 145**

**Waterblasting  
Equipment****Giant Industries**

Toledo, OH  
800-633-4565 • 419-531-4600 • Fax: 419-531-6836  
sales@giantpumps.com  
www.giantpumps.com

**Hammelmann Corp.**

Dayton, OH  
800-783-4935 • 937-859-8777 • Fax: 937-859-9188  
mail@hammelmann.com  
www.hammelmann.com

**Hot Jet USA**

Riverton, UT  
800-624-8186 • 801-545-0777  
sales@powerlineindustries.com  
www.hotjetusa.com  
**Ad on page 147**

**Joe Johnson  
Equipment****Joe Johnson Equipment, Inc.**

Innisfil, ON  
Canada  
800-263-1262 • 705-733-7700 • Fax: 707-733-8800  
info@jjei.com  
www.jjei.com

**Milwaukee Rubber Products, Inc.**

Menomonee Falls, WI  
800-325-3730 • 262-781-7888 • Fax: 262-781-1742  
dennis@milwaukeerubber.com  
www.milwaukeerubber.com  
**Ad on page 147**

**NLB Corp.**

Wixom, MI  
800-227-7652 • 248-624-5555  
nlbmtg@nlbusa.com  
www.nlbcorp.com

**NozzTeq, Inc.**

Clearwater, FL  
866-620-5915 • 727-223-4979 • Fax: 603-413-6744  
info@nozzteq.com  
www.nozzteq.com  
**Ad on page 105**

**Sonetics**

Portland, OR  
877-959-9189 • 503-684-7080  
sales@soneticscorp.com  
www.soneticscorp.com/public-works

**SubSurface Instruments, Inc.**

De Pere, WI  
855-422-6346 • 920-347-1788 • Fax: 920-347-1791  
paul.renard@ssilocators.com  
www.ssilocators.com  
**Ad on page 144**

**The Plug Hug**

Bellville, OH  
719-313-2791 • Fax: 419-525-2386  
douglassmarshall@theplughug.com  
www.theplughug.com  
**Ad on page 145**

**TST Sweden AB**

SE-511 54 Kinna  
Sweden  
4-632-020-5880  
info@tst-sweden.com  
www.tst-sweden.com

**Welders****PK Safety**

Alameda, CA  
800-829-9580  
pks-store@pksafety.com  
www.pksafety.com  
**Ad on page 148**

**Vanair Manufacturing**

Michigan City, IN  
800-526-8817 • 219-879-5100 • Fax: 219-879-5800  
marketing@vanair.com  
www.vanair.com



# POWERFUL. RELIABLE. RESULTS.

THE IMPROVED PATHFINDER MODEL TR3310

LARGE LINE KIT:  
TO 36-INCH PIPE  
AND LARGER.

STANDARD  
CONFIGURATION:  
6- TO 24-INCH PIPE.

NEW!



The improved drive components on the Pathfinder Model TR3310 operate with greater power for longer pulling distance. The robust system, with quick set-ups and a compact profile, keeps your crews operating faster and longer.

- Better traction for great maneuverability
- Pan & Tilt camera with self-cleaning lens
- Electric lift to remotely center camera
- Rear camera and free-wheel for fast retrieval
- Wireless control with Xbox 360® controller

Get the inspection results you need. Call Aries today.

COME SEE US AT:  
**WEQFAIR**  
MILWAUKEE

**ARIES**  
INDUSTRIES, INC.

See what you're missing.

[www.ariesindustries.com](http://www.ariesindustries.com)  
(800) 234-7205

© Aries Industries, Inc.



## It's black and white.

In every issue of *Municipal Sewer & Water*, you'll read all about sanitary sewer, stormwater and water system professionals. You'll discover:

- Who are the innovators in system repair and maintenance
- How they make sound decisions that improve service and save money
- What tools and technologies drive efficiency and performance
- Where to go to find the latest equipment and advice

## No gray area here.

*Municipal Sewer & Water* has it all. And it's **FREE**.

Start your subscription today at [mswmag.com](http://mswmag.com)  
or call 800-257-7222.



# A New Solution for **ODOR & CORROSION** in **SEWER FORCEMANS**



## **Vortex FORCE™** ODOR & CORROSION CONTROL

The Vortex Force™ is a specially designed aeration device for sewer forcemans, wet wells, storage tanks and irrigation ponds to reduce odor and corrosion. VortexForce easily installs using a simple flange connection in flows ranging from 125 GPM to 2,616 GPM.

### APPLICATIONS



Sewer Force  
Main Discharge



Sewer Wet Wells  
& Storage Tanks



Irrigation  
Ponds



### FEATURES & BENEFITS

- Aerates flow to increase dissolved oxygen concentration of incoming sewage
- Easily connects using simple flanges and supports
- Covers a wide range of flows from 125 GPM to 2616 GPM
- Saves money by reducing the need for costly chemical feeds, biofilters & air scrubbers

To learn more, call us toll free at **1-800-463-9572** or visit [ipexna.com](http://ipexna.com)

Product is manufactured by IPEX Inc. and distributed in the United States by IPEX USA LLC. Vortex Force™ is a trademark of IPEX Branding Inc.





# STORMWATER MANAGEMENT AND I&I PREVENTION

By Craig Mandli

## COATINGS

### 1. AP/M Permaform CentriPipe

The **CentriPipe** trenchless rehabilitation system from **AP/M Permaform** provides structural relining using a bidirectional spincaster and PL-8000 specialty mortar. The precisely placed and compacted concrete liner is applied at the best design thickness for the diameter and conditions. It contains rust inhibitors to prevent corrosion of the old metal and is resistant to abrasion. This process provides waterproofing, sealing, structural reinforcement and corrosion protection, maximizing the pipe interior for capacity and flows while providing a fully structural “pipe within a pipe.” **800/662-6465; www.permaform.net.**

### 2. Avanti International AV-100

**AV-100** from **Avanti International** is an ultralow viscosity, chemically reactive gel available as either granules or liquid. It has similar viscosity to water, can permeate anywhere water can travel, and cures within a controllable set time — anywhere from five seconds to more than 10 hours. Once cured, it creates an effective, long-lasting water barrier while providing soil stabilization. It can be used to rehabilitate and sustain stormwater and sanitary sewer collections systems to eliminate infiltration in manholes, mainlines, joints and laterals, and various other underground structures by stabilizing external substrate. By eliminating infiltration, there is a reduction in excess flow to wastewater treatment plants, reduced treatment costs, and added life expectancy of underground infrastructure. **800/877-2570; www.avantigrout.com.**

### 3. Coatings for Industry Wearcoat 481HP

**Wearcoat 481HP** high-performance floor topcoat from **Coatings for Industry** was formulated to be both anti-yellowing and fade-resistant. This epoxy is designed for applications where the floor has exposure to the sun or high-intensity lighting. While all epoxies will eventually yellow, it will take twice the exposure for it to change noticeably, while also improving wear resistance. It is effective in providing a seamless floor with good resistance to an array of hazards. It is ideal for application at facilities that are in service because it has zero VOCs and extremely low odor. Decorative options including flakes, quartz and metallics are available. **877/723-0919; www.cfcoatings.com.**

### 4. Epoxytec Mortartec Ceramico

**Mortartec Ceramico** epoxy-modified mortar from **Epoxytec** is a blend of epoxy technology combined with hardened ceramics. The result is a smooth mortar application with a hard, sealed surface once cured. It provides a chemical-resistant mortar and eliminates up to 95 percent of out-gassing. It provides same-day recoat, epoxy topcoat three hours after applied, and ideal epoxy-assisted adhesion. There is no need for further preparation after cure (zero laitance). It has ultrathin film capability (as low as 1/16 inch safely), up to 1 inch per pass. It increases adhesion to both underlayment and epoxy topcoat. **877/463-7699; www.epoxytec.com.**

### 5. Raven Lining Systems Raven 405

**Raven 405** from **Raven Lining Systems** is a solvent-free, 100 percent solids, ultra-high-build epoxy coating formulated with high physical strengths and broad-range chemical resistance. It exhibits superior bond to concrete, steel, masonry, fiberglass and other surfaces. Designed for operating temperatures up to 200 degrees F, its ultra-high-build ability allows it to be spray-applied on vertical and overhead surfaces. Its surface tolerance and high physical strength allow it to be designed as a structural lining in manholes, pipelines, tanks and other deteriorated structures. **800/324-2810; www.ravenlining.com.**

### 6. Sauereisen Manhole ChimneySeal No. F-88

**Manhole ChimneySeal No. F-88** from **Sauereisen** helps prevent water inflow and infiltration within the chimney section of manholes. It is an elastomeric lining composed of fiber-reinforced, asphalt-modified urethane that maintains elasticity and adhesion from minus 30 to 250 degrees F. Its flexible nature allows it to withstand the forces that frequently cause breaches in manhole chimneys. By sealing this particularly vulnerable section of the manhole, it is possible to avoid the penetration of groundwater that would otherwise be treated as sewage. After two components are mixed, the slurry is simply wiped onto the surface of the manhole by hand while wearing a glove. No mechanical fittings are required, as it will bond to the contour of the structure without gaps. **412/963-0303; www.sauereisen.com.**

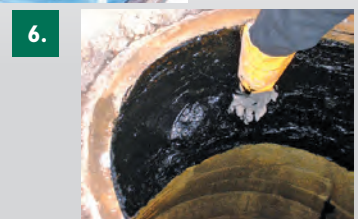



## 7. The Strong Company Storm Seal

Storm Seal from **The Strong Company** is a specially formulated, fiber-reinforced, cementitious mixture designed for lining the interior of corrugated metal pipes, culverts, concrete pipes, catch basins and other stormwater structures. It is centrifugally cast using the Strong-Seal System mixer, pump and spinner, which are electronically controlled for consistent product and thickness of application. It may also be sprayed manually. **800/982-8009; [www.strongseal.com](http://www.strongseal.com).**

## INFILTRATION AND LEAK PREVENTION

## 8. HydraTech Engineered Products HydraTite

The **HydraTite** internal pipe joint sealing system from **HydraTech Engineered Products** is a mechanical, trenchless remediation for leaking pipe joints consisting of a rubber seal that spans the joint and is held in place by stainless steel bands on either side. The retaining bands are hydraulically expanded and locked in place, eliminating all possibilities of infiltration or exfiltration. **513/827-9169; [www.hydratechllc.com](http://www.hydratechllc.com).**

## 9. LMK Technologies T-Liner

The **T-Liner** from **LMK Technologies** is a one-piece homogenous main and lateral CIPP connection liner that is ASTM F2561-compliant. It has a uniform wall thickness and incorporates compressible lining material at the upstream and downstream ends, creating a smooth tapered transition to the host pipe. Both the mainline and lateral sections are formed as a structural cylinder that renews 18 inches and 360 degrees of the mainline and extends up the lateral pipe as one continuous lining. T-Liner with Insignia compression gasket sealing technology provides a verifiable non-leaking system. These compression gaskets are embedded between the host pipe and the T-Liner and are compatible with all pipe types, including polyethylene. **815/433-1275; [www.lmktechnologies.com](http://www.lmktechnologies.com).**

## 10. Logiball Lateral Test and Seal Grouting Packers

**Logiball Lateral Test and Seal Grouting Packers** for trenchless rehabilitation of collections systems are used to stop infiltration at lateral connections and in lateral joints all from the mainline sewer access as far as 30 feet from the mainline. They are available for 6- through 144-inch pipe diameters. Packers for elliptical and box culverts are available. Flexi-

ble push/pull packers are used to seal the laterals from an above-ground access or laterals coming into manholes. Chemical grouting seals the soil around the injection points, preventing washout of backfill into the sewer and sealing off infiltration. **800/246-5988; [www.logiball.com](http://www.logiball.com).**

## 11. Prime Resins Prime Flex 920

**Prime Flex 920** from **Prime Resins** is a versatile, single-component, water-activated polyurethane resin that is ideal for stopping infiltration. It is used to seal gushing leaks, including wide gaps, in concrete where the structure is not subject to movement. This hydrophobic material reacts with water and expands to form a closed-cell, watertight, rigid foam. Its super-low viscosity allows for penetration into fine areas. It can be used for sealing leaks and filling voids in and around box culverts, tunnels, manholes and pipes. It is also ideal for curtain grouting below-grade structures like parking decks, foundations and basements. Adjustable reaction times range from four to 13 seconds. It is independently verified to meet NSF/ANSI Standard 61.5 for contact with potable water, allowing for use in the most sensitive areas. It is available in pails and drums, as well as cartridges. **800/321-7212; [www.primeresins.com](http://www.primeresins.com).**

## 12. Sealing Systems Infi-Shield Gator Wrap

**Infi-Shield Gator Wrap** from **Sealing Systems** prevents infiltration and erosion by providing a watertight seal around any manhole, catch basin or pipe joint. It resists harsh soil conditions and provides a root barrier for any crack or joint. It is made of a stretchable, self-shrinking, intra-curing halogenated-based rubber with a minimum thickness of 30 mils. The backside of each seal is coated with a cross-linked reinforced butyl adhesive. The seal is designed to stretch around the joint and then overlap, creating a cross-link and fused bond between the rubber and butyl adhesive. It installs easily with no special tools and can be immediately backfilled. **800/478-2054; [www.sssealingsystems.com](http://www.sssealingsystems.com).**

## 13. Source One Environmental The Phoenix

**The Phoenix** heated packer from **Source One Environmental** helps eliminate infiltration by helping point repairs cure 50 percent faster. It has an internal heater powered by 230 or 110 volts, ensuring full control of the hardening process regardless of the outside temperature. The pre-programmed digital display on the heated control unit shows the actual temperature of the packer, allowing the technician to regulate the entire curing process and increase daily work capacity. It installs and cures like the Standard PipePatch system to create structurally rehabilitated spot repairs

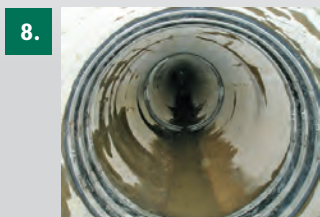
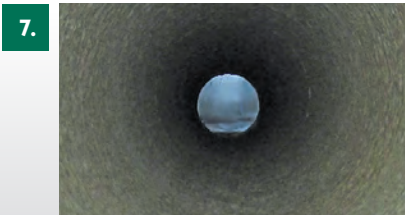

in sanitary sewer and stormwater applications. It exceeds ASTM F 1216 and complies with NSF, ICC-ES PMG and IAPMO UPC certification standards. **877/450-3701; www.s1eonline.com.**

**14. Southland Tool Arrow Diamond Calcium Cutter**

The **Arrow Diamond Calcium Cutter** for hydraulic jet motors from **Southland Tool** helps remove deposits of calcium carbonate caused by infiltration. Over time this tuberculation will form in the pipe and make rock-hard deposits that reduce flow, cause blockages and preclude TV inspection. The cutter is made of thick 1/4-inch reinforced steel with a welded 1-inch arbor hub. The front arrow divides into four fins to start in the middle of the deposits. Each of the four tapered fins has a thick 1/4-by 2-inch diamond segment brazed to the steel. They will chop and break away calcium deposits. Working into deposits breaks off chunks that will be jettisoned downstream. It is suggested to have a camera looking at the cutter from the upstream position. **714/632-8198; www.southlandtool.com.**

**15. Strike Products I & I Barrier**

The **I & I Barrier** from **Strike Products** is designed to stop water from leaking into a manhole through the grade rings. It has no adjustment bands or flexible rubber material, as its rigid polyethylene barrier wall dams water and stops it from entering manholes. It is easy to install, and can be adjusted for different road variations. The manhole remains clean during the construction, as no debris can fall into the manhole. Inspection of the completed process is easy. **800/262-4129; www.striketool.com.**

**MANHOLE REHABILITATION**

**16. Abart Industries Top Hat risers**

**Top Hat** recycled rubber manhole risers from **Abart Industries** are a cost-effective reusable product that offers a cure for castings. They are custom fit to apply to any manhole design, absorbing impact from traffic and protecting the manhole structure. They help reduce water infiltration and wear and tear on vehicles while exceeding the life of the pavement. They are UV-resistant, and heavy equipment is not needed to install them. Bolt packages are included, and they can be installed within 30 minutes, reducing lane closure times. They can be applied before or after blacktop application, making them a solution for after-thought adjustments. **315/730-2588; www.tophatrisers.com.**

**17. Cretex Specialty Products PRO-RING**

**PRO-RING** from **Cretex Specialty Products** is an advanced concrete-alternative manhole and catch basin grade adjustment system. Available in round, square and rectangular models, these rings are manufactured from expanded polypropylene, which is renowned for its strength-to-weight ratio, durability, chemical resistance and long service life under harsh conditions. One man can install the system in just minutes to within a 1/4 inch of finished grade, and they are watertight. Where concrete rings break and may cause injury, the system eliminates that hazard, helping minimize the risk of injury. A 6-inch unit weighs 14 pounds and stands up to physical abuse, speeding manhole installation and repair time. Manhole repair sites can be opened, repaired and closed in one day, reducing overall costs. Angle rings are available to match slopes, eliminating the need for mortar and shimming. **800/345-3764; www.cretexseals.com.**

**18. H2TR MPR100**

The **MPR100** manhole protection ring from **H2TR** protects lines from the rough edges of manholes by simply dropping it into the manhole prior to any equipment. It is produced in a highly visible safety orange to help identify the site and the open manhole, reducing potential hazards. It provides a full 360-degree area of edge protection. **517/204-2121; www.h2tr.com.**

**19. Huber Technology manhole covers**

Manhole covers from **Huber Technology** are available in 304L or 316L stainless steel. The durable covers offer absolute corrosion protection by pickling and passivation. They provide permanent safety for people and the environment. The weatherproof square-type covers can be used in well shafts, shafts at sources, steam ventilation shafts, wastewater shafts, sump shafts and cover shafts. Options include an air vent, insulation, odor control carbon filter and rubber gaskets. **704/949-1010; www.huberforum.net.**

**20. Mr. Manhole Six Shooter Gold Series**

The **Six Shooter Gold Series** manhole cutter from **Mr. Manhole** has carbide cutting teeth with a curved profile, improving the longevity of the teeth and providing faster cutting. The cutting teeth can be replaced on the job site, in seconds. The tool has an adjustable cutting diameter with a quick-adjust function that allows for quick diameter changes without tools. The auger has been enhanced to include a 2.5-inch hex connector. With a universal mounting plate, the auger connects to all skid loaders, regardless of make and model. Hose connections are Stucchi A13 SAE 3/4-inch. In conjunction with the enhanced auger, the weight of the frame has been increased for a smoother cutting experience. **419/741-9075; www.mrmanhole.com.**

(continued)

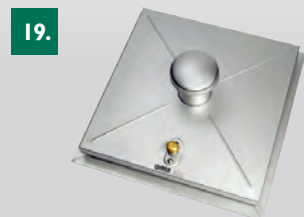





# TerraThane™ Geotechnical Polyurethane Foam

You name it and TerraThane™ has probably been used on the project.

NCFI Polyurethanes pioneered “foamjacking”— the use of high-density polyurethane foam as a lightweight and structurally strong replacement for conventional mudjacking for lifting, leveling, and stabilizing concrete foundations.

- Public utility plants**
- Office buildings**
- Meeting and exposition venues**
- Hospitals**
- Hotels**

- Sports venues**
- College/university landmarks**
- Visitor centers**
- Warehouses**
- Parking garages**



*Our TerraThane™ concrete-specific geotechnical foam systems are lighter, more durable, easier to apply, less intrusive and much simpler to clean up.*

Faster, Cleaner and More Affordable Concrete Slab Lifting, Leveling and Soil Stabilization



[www.NCFI.com](http://www.NCFI.com)





**21.** Parson Environmental Products Pro50 Starter

The **Pro50 Starter** manhole rehabilitation system from **Parson Environmental Products** has been upgraded to include a 2 hp motor and faster paddle speed. The lightweight and portable unit has a larger drum diameter and a greater batch output than the previous model. Other notable changes include improved handles and wheels for easier movement. **800/356-9023; www.parsonenvironmental.com.**

**22.** Perma-Liner Industries CIPMH

The **Perma-Liner Industries** trenchless **CIPMH** one-size liner provides all the benefits of CIPP. It is simple to install and completely renews a manhole in a couple hours. It requires no digging, resulting in minimal disruption to the public. It is made to fit all manholes, including barrel sections, eccentric and concentric cones constructed of brick and mortar, precast or block. The liner for chimney or full-depth manholes eliminates infiltration and inflow through manhole walls. This universal-sized liner is engineered to resist freeze-thaw cycles and create a watertight, corrosion-resistant structural lining. **866/336-2568; www.perma-liner.com.**

**23.** RELINER Manhole Channel Repair System

The **RELINER Manhole Channel Repair System** is a molded fiberglass flume with a smooth sewer pipe interface used to rehabilitate inverts without flow interruption, and can also be used in new construction. The field-installed modular components bolt together with minimal tools, are adaptable to a wide range of field conditions and manhole sizes, and are compatible with all current field manhole-lining systems. The full-depth lined channels are high flow and easy to clean and maintain. Standard 8- and 12-inch-depth channel sections fit through a 24-inch manhole frame and will accommodate 6- through 12-inch pipes. Larger sizes are available. **800/508-6001; www.reliner.com.**

**24.** USB - Sewer Equipment Corporation Alphajet

The **Alphajet** cleaning nozzle from **USB - Sewer Equipment Corporation** is designed to clean grease, sludge and crusts from lift stations and manholes prior to rehabilitations. It is actuated by water coming from the pressurized hose of the jetter truck. Four driving nozzles cause 360-degree controlled rotation in a horizontal plane, eliminating the need to cover the manhole. The horizontal rotation allows for obser-

vation of the cleaning progress. The body requires no lubrication or replacement of internal mechanical parts within the first 12 months of operation, making it user-friendly. Driving nozzles can be extended to accommodate various sizes of manholes/lift stations. **866/408-2814; www.usbsec.com.**

**25.** WHIRLYGIG system

The **WHIRLYGIG** method of manhole riser/collar installation is size-accurate, installs in minutes and leaves no doubt about quality control. Simply place a form on the manhole cone, trim the form to grade with the radial arm trimmer, place the manhole ring, check accuracy and pour redi-mix. The system streamlines installation into a process that works every time and produces a sturdy installation. **800/307-4263; www.wgig.us.**

**PRETREATMENT**

**26.** WesTech Engineering FlexFilter

The **FlexFilter** from **WesTech Engineering** uses compressible media to provide an efficient solution for CSO, primary treatment, tertiary treatment and industrial water pretreatment. It is a simple gravity system with a durable design requiring no moving parts. The combination of tapered media compression, porosity gradient within the media bed and a low-flow backwash system makes it versatile and efficient. **801/265-1000; www.westech-inc.com.**

**27.** Yardney Water Filtration Systems Filtaworx

**Filtaworx** automatic self-cleaning screen filters from **Yardney Water Filtration Systems** are designed for cooling towers, industrial process water, incoming plant water, wastewater cleanup and industrial water for plant reuse. The system can be mounted in any position or orientation. It removes algae, slime, organic contaminants, sand grit and inorganic contaminants with fine-mesh filtration to 50 microns. Eight models handle flow rates from 444 gpm to 3,960 gpm. Features include corrosion-resistant 304 stainless steel filter body and self-cleaning mechanism. **951/656-6716; www.yardneyfilters.com. ♦**

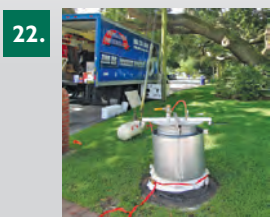
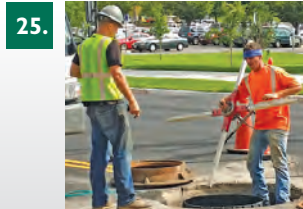



YOU ARE ONLY GETTING  
HALF THE PICTURE  
if you aren't using  
**PANORAMO 360°**  
DUAL-CAMERA Technology!

Every pipe has a story.  
Let us help you find it.



(800)-656-4225 | [www.rapidview.com](http://www.rapidview.com)

weftec 2016  
Booth 7739



## HDPE pipe solves swamp problem for airport expansion



**Problem:**

Building the 3,300-foot-long, east-west runway at Grand Forks International Airport in North Dakota required that swampland around it be properly drained because it could not support any load.

**Solution:**

Ulteig Engineers designed the drainage system using 18- to 60-inch-diameter pipe connected in a herringbone pattern in cover ranging from 4 to 5 feet. More than 3.5 miles of **MEGA GREEN** corrugated high-density polyethylene pipe made with a minimum of 40 percent recycled content was specified. The pipe from **Advanced Drainage Systems** has a pre-drilled perforation pattern that allows groundwater to enter the system and be conveyed away. The pipe is available with a soil-tight or watertight joint in diameters from 12 to 60 inches for gravity-flow drainage systems. Its structural strength will support H-25 live loads and meets ASTM F2648 standard specifications.

**RESULT:**

At the start of construction the land itself was the problem. “Bulldozers were getting stuck two to three times a day,” says Ryan Jones of Ulteig. “The land around Grand Forks is extremely flat, and the infield is actually below the rest of the grade. It was a bog that didn’t have any structural stability. This had to be corrected, and we did it by using the HDPE pipe. And so far it’s been working beautifully.” **800/821-6710; www.ads-pipe.com.**

## Stormwater chambers installed under space-constricted parking area



**Problem:**

The Crossroads at Firestone Boulevard shopping center in South Gate, California, required a stormwater management plan that would direct stormwater runoff according to zoning regulations and work effectively in a limited space under the future parking lot of the new plaza. Regulations require

that stormwater be held back on site to prevent entering the public water systems. The best option was a subsurface stormwater management system; however, soil at the job site was silty and sandy, making stability difficult.

**Solution:**

Plastic underground stormwater chambers from **CULTEC** were chosen

due to their reputation, ease of installation and widespread product availability. Delta Pipeline installed the **Recharger 330XLHD**, a 30.5-inch-tall, high-capacity stormwater chamber that allowed for a condensed installation area. The company installed 392 chambers amongst five areas, and provided 34,969 cubic feet of storage within 17,542 square feet. The units measure 8.5 feet long by 52 inches wide. Per the design, each chamber was able to store and infiltrate over 667 gallons of stormwater, localizing the runoff to the plaza’s location.

**RESULT:**

“The real issue was the sandy soil,” says Marco Leon, site foreman with Delta Pipeline. “With the **CULTEC** chamber, install was perfect: no problems off-loading or installing the system with difficult soil conditions. We needed few additional materials to increase the system’s stability.” Over the two-week installation, the team had no complications. **800/428-5832; www.cultec.com.**

## Epoxy and PVC adhesive used in transition between T-Lock and concrete manhole

**Problem:**

Nine wet wells required coating of floors with a reliable connection to a previously installed PVC T-Lock liner at the Maui County Wastewater District in Hawaii.

**Solution:**

**Neopoxy International** recommended using a combination of solvent-free PVC adhesives and epoxy resins for this project. Coating Works Hawaii applied a 1-inch-wide strip of PVC adhesive on the low edge of the T-Lock sheet. The next day the floor was coated with highly corrosion-resistant **NPR-5305** epoxy overlapping the PVC adhesive strip. The epoxy coating bridged the PVC material with the concrete wet well floor.



**RESULT:**

The combination of PVC adhesive and **NPR-5305** epoxy resin created a reliable transition between PVC material and concrete structure. **510/782-1290; www.neopoxy.us.**

## Combination of products used to decrease infiltration

**Problem:**

The city of American Fork, Utah, recently completed a trenchless wastewater rehabilitation project primarily aimed at diminishing infiltration in a busy and growing business center that is home to a number of tech businesses in the area.

*(continued)*





# Risk Management

Matchpoint's multi-faceted risk management program provides the technology and tools for remotely and continuously assessing the condition of the water network, thus minimizing risk by instantaneously highlighting any anomalies. As a result, along with the implementation of our leak detection program, water loss and lead times from leak discovery to repair are drastically reduced and storm water run-off becomes manageable.

*More data, less risk.*

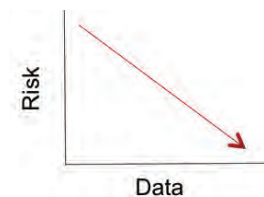

## Continuous Condition Assessment

Evaluates the health of the water network

### KEY FEATURES

- Data accrual through continual and remote pipe monitoring
- Analysis of historical data
- Reduces leak runtime
- Decreases risk of damage to assets
- Improves water quality assurance
- Reduces overall water loss and non-revenue water
- Monitor up to 100 inch pipe

## Infrastructure Management

A comprehensive leak detection package

### KEY FEATURES

- Pinpoint and confirm leaks across the network
- Quantify the leakage rate to prioritize repairs
- Reduces water loss and non-revenue water
- GPS leak location
- GIS integration
- Accurate reporting
- Reduces leak runtime

## Manage Storm Water Run-Off & Sewer Intrusion

Minimize ground water saturation

### KEY FEATURES

- Reduces ground saturation and overland flow from detection of underground leakage
- Minimize risk of flooding, pollutant transport, and damage to underground assets
- Protects water quality
- Reduces sewer intrusion



For more information contact  
[sales@matchpointinc.us](mailto:sales@matchpointinc.us) or 910-509-7225



**Solution:**

The city and its engineer selected a combination of UV-cured CIPP lining, lateral lining, as well as manhole rehabilitation using high-performance epoxy and chemical grouting. Manhole products included **Sewer Shield Composite 150**, a 100 percent solids high-build epoxy, **C-120** build-back mortar, and

hydrophobic chemical grout, all manufactured by Environmental Coatings.

**RESULT:**

Despite the small project size, the results of using this comprehensive, multi-technology trenchless rehabilitation approach to reduce infiltration and control corrosion in the system were dramatic. The manhole coating and lining system performed superbly, and combined with the UV-cured CIPP pipe and lateral lining technologies, the city realized an infiltration reduction of approximately 100 gpm, resulting in significant long-term savings in treatment costs. **480/830-9537; [www.sewershield.com](http://www.sewershield.com).** ♦

What's Read All Over?

MUNICIPAL  
**SEWER  
&  
WATER**  
MAGAZINE

[mswmag.com](http://mswmag.com)



*Extra!  
Extra!*

## Want More Stories?

Get more news,  
information,  
and features  
with our  
exclusive  
online content.

Check out

### Online Exclusives

at

[www.cleaner.com/online\\_exclusives](http://www.cleaner.com/online_exclusives)

MUNICIPAL  
**SEWER  
&  
WATER**<sup>TM</sup>





## “Introducing: The Lateral Lining And Spot Repair System”

**FORMADRAIN is a steam Cured-in Place Pipe Lining (CIPP) system specially engineered for laterals & spot repairs!**

We have a proven and virtually perfect pipe lining system for laterals and spot repairs.

Here’s why:

- It’s practically indestructible
- Cures five times stronger
- No stitching felt
- No measuring for transitions
- Absolutely no digging

### Is This Really Different?

Yes. You can’t compare this to other systems—they are in totally different categories.

This isn’t “a CIPP system.” This is *the* CIPP system for laterals and spot repairs.

This doesn’t use a felt tube but epoxy and woven fiberglass. Also it’s pulled or pushed into place — so that you can place the epoxy pipe *exactly* where you want it.

And you have plenty of working

time because of the steam curing.

### Look At Your Benefits:

Why is Formadrain worth a hard look for any plumber or sewer contractor? No fluff, no hype: this system works, really well.

- **Lining T’s, Y’s and Offset Joints:** Tees, Ys and offset joints aren’t a problem and it doesn’t matter whether you’re doing a 4” to 6” transition or have an offset joint. You don’t even have to measure —it will adjust.
- **Exceptional Customer Support:** We’re going to give you and your crew personal training and preparation so you can get into the field fast.

And our engineers will help you with technical questions any time between 8:00 AM and 8:00 PM.

- **Incredible Strength:** The woven fiberglass and steam-cured epoxy is very strong — we haven’t found *any one else* with a stronger product.
- **Quality of the Product:** The finished product is amazingly uniform and due to the fiberglass and epoxy design there are no wrinkles.
- **Perfect Spot Repairs:** Because you can pull the system in place exactly where you want it, you can repair a precise section of pipe. It is so good at spot repair, some use it for this reason alone.

### See For Yourself!

Do the research and it will change the way you look at spot repairs and lateral lining.

Get a free information pack on the system or have us do a live demonstration (at your location).



Jim with Levine & Sons, a Formadrain installer for approximately 8 years

“We can re-line through a 4-inch cast iron clean out, a Y in a 45 and go right to the city main with zero digging...”

We can do the 4 to 6 transitions without measuring...The fiberglass epoxy just opens up beautifully and you get a nice, seamless transition.

Also the support we get is second to none. You can call any time, day or night...”

**Find out more with our FREE Info Kit!**

Download at [www.Laterals.org](http://www.Laterals.org)

Call (888) 668-2795 or email Bruce at [bruce@formadrain.com](mailto:bruce@formadrain.com)



# Product Spotlight

## Compact Ventis Pro5 simplifies gas detection and response

By Luke LeNoble

The Ventis Pro5 multi-gas monitor from Industrial Scientific can detect up to five gases simultaneously, including toxic and combustible gases such as ammonia, carbon monoxide, hydrogen sulfide, hydrogen cyanide and methane. Acknowledgeable alerts provide early warning to let users know when they are in the presence of gases below the low-alarm level.

“It’s small and compact — it’s the smallest five-gas detector on the market — and it’s got flexible sensor configurations,” says Chris Lange, director of marketing for Industrial Scientific. “You can detect a large combination of gases in one compact, personal monitor.”

Designed with flexible sensor configuration options, the monitor takes gas readings every second and records readings-related data every 10 seconds.

“All gas monitors are designed to notify people of dangerous and hazardous conditions,” Lange says. “But with the Ventis Pro, specifically, there are a lot of extra benefits to raise the bar on worker safety, such as alarm-action messages.”

The messages provide written instructions during low- and high-alarm events, helping workers react appropriately.



“The Ventis Pro Series simplifies gas detection for users,” Lange says. “Instead of a user having to interpret how to respond when an instrument goes into alarm, they can focus on taking action in emergency situations with on-screen alarm action messages like ‘EVACUATE,’ or ‘VENTILATE.’”

A dedicated panic button and man-down alarm alert nearby workers when someone is in distress or loses consciousness. iAssign Technology tracks users and sites in real time using Near Field Communication to help safety managers identify and address job site gas hazards and improve asset management.

“You assign users and sites to each gas monitor,” Lange says. “You have accountability now. You know who had an instrument and where it was during an alarm.”

The instrument is available with an integral pump for confined spaces or without integral pump for personal protection. Both are IP68-rated for protection against damage from dust and water. **412/788-4353; www.indsci.com.**



### Vac2Go ceramic-lined porthole elbows

Ceramic-lined porthole elbows from Vac2Go are designed to last longer than steel porthole elbows and reduce downtime. Ceramic-lined elbows feature wear resistance, extending the life of vacuum truck fittings, and are available in 45 and 90 degrees. **855/822-7426; www.vac2go.com.**

### COXREELS stainless steel reels

Stainless steel and powder-coated steel reels from COXREELS are available in either 316 or 304 grade to best match the necessary corrosion resistance of the reel according to the application. **800/269-7335; www.coxreels.com.**

### SubSurface Instruments locators

The AML Pro and AML+ all-material locators from SubSurface Instruments use ultrahigh radio frequencies to locate buried plastic, metal, wood, cable and pipe in any soils at depths of more than 20 feet. Locators feature digital micro-processor technology, a lithium rechargeable battery pack and GPS reporting, eliminating the need for auxiliary tracking equipment on the job site. **855/422-6346; www.ssilocators.com.**

(continued)



# CHEAPER THAN WATER. TOUGHER THAN F.O.G.

**Grease Release gets sewer pipes cleaner than other products while remaining more cost-efficient than using water alone.**

Scientifically formulated Grease Release emulsifies grease which never re-solidifies and coats each pipe with surfactants, slowing future build-ups and enhancing preventative maintenance.

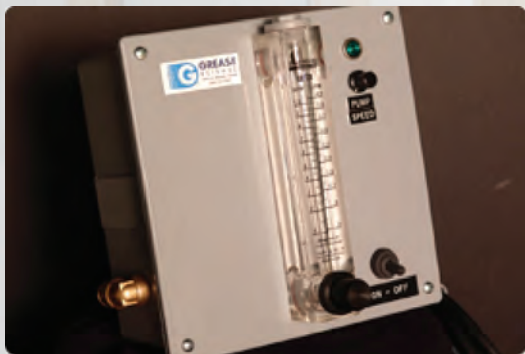

The Grease Release Metering System:  
**NEVER WASTE CHEMICALS AGAIN.**

*Get the most out of every drop of Grease Release with the optional metering system. It's been engineered to deliver the exact concentration for the job at the turn of a dial, eliminating measuring and mixing and, more importantly, eliminating the expense of under-applications and over-applications.*

The Grease Release Metering System installs quickly and easily on any jetter truck.



**Call Today and Say Goodbye to Grease!**

**1-800-841-1444**

## Franklin Electric grinder pumps

IGP Series grinder pumps from Franklin Electric operate across 208 to 230 volts. The IGP-A (automatic) and IGP-M (manual) are designed to handle low-pressure sewage applications and feature a cutter system that operates at 414,000 cuts per minute. Other features include a non-clogging, corrosion-resistant brass impeller with a shut-off head of 130 feet and a 2 hp single-phase, 3,450 rpm start/run motor with built-in overload protection. **260/824-2900; [www.franklinwater.com](http://www.franklinwater.com).**



Franklin Electric IGP Series

## Sensoray embeddable digital video recorder

The Model 4012 compact digital video recorder from Sensoray is designed to be embeddable in OEM systems. It records audio and video to USB storage in MP4 format and captures JPEG images without interrupting recording. Two incremental encoder interfaces allow position information to be overlaid directly onto the video. The A/V outputs allow live video, recorded A/V or JPEG images to be displayed on an external monitor. A real-time clock maintains date and time with battery backup. **503/684-8005; [www.sensoray.com](http://www.sensoray.com).**

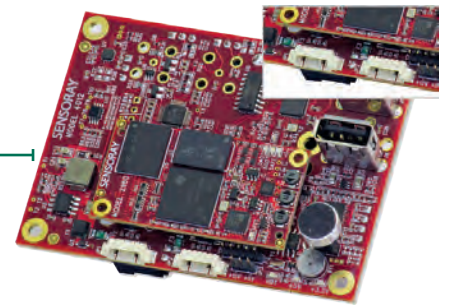

Sensoray Model 4012

## Flygt - a Xylem Brand wastewater pumping system

The Concertor wastewater pumping system from Flygt - a Xylem Brand features integrated intelligence that senses the operating conditions of its environment, adapts its performance in real time and provides feedback to pumping station operators. The system's compact design reduces cabinet size by up to 50 percent and clog-free pumping reduces energy and cleaning costs. **203/712-8999; [www.flygtus.com](http://www.flygtus.com).**



Flygt - a Xylem Brand Concertor

## McLaughlin utility locator

The Vermeer Verifier G3 utility locator from McLaughlin features a durable design with antennas mounted in rubber isolators for tough job site conditions. A new combination screen eliminates the need for users to toggle between two screens. Users can engage the semiautomatic gain on urban or congested job sites where signal distortion is common, or use the manual gain method when working in less congested areas. Estimated depth is automatically displayed instead of having to manually press a button. A compass icon provides straightforward visual representation of a utility's position in reference to the receiver. **800/435-9340; [www.mclaughlinunderground.com](http://www.mclaughlinunderground.com).**



McLaughlin Verifier G3

## PSI Pressure Systems Corp high-pressure pumps

The NX-Series (NX-365, NX-600 and NX-800) of high-pressure pumps from PSI Pressure Systems Corp are designed for waterblasting applications. Operators can match most nozzle sizes with the unit displacement because of the pumps' standard transmissions and electronically controlled engines. The Smart Water System conversion system operates in a pressure range of 8,000 to 40,000 psi (300 bar and 2,800 bar) without having to change or remove the discharge manifold, accessory manifold, rupture disc assemblies or pressure gauges. Pumps cannot be operated with a conversion kit that does not match the rupture disc. **855/775-5055; [www.psi pressuresystems.com](http://www.psi pressuresystems.com).**



PSI Pressure Systems NX-Series

(continued)



# Our experience and knowledge elevates us heads and shoulders above the competition.

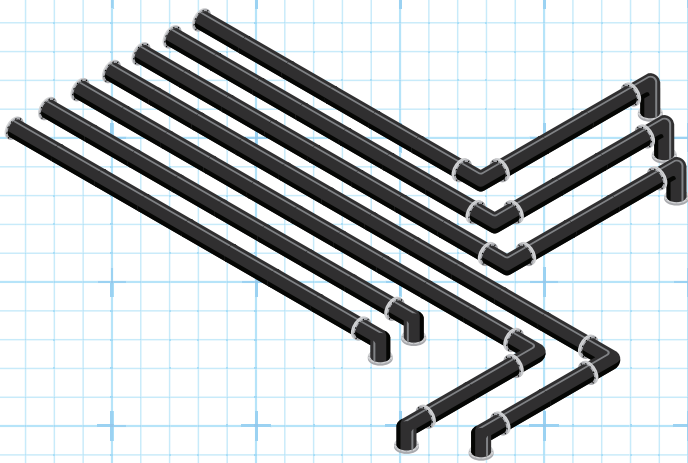

**US**

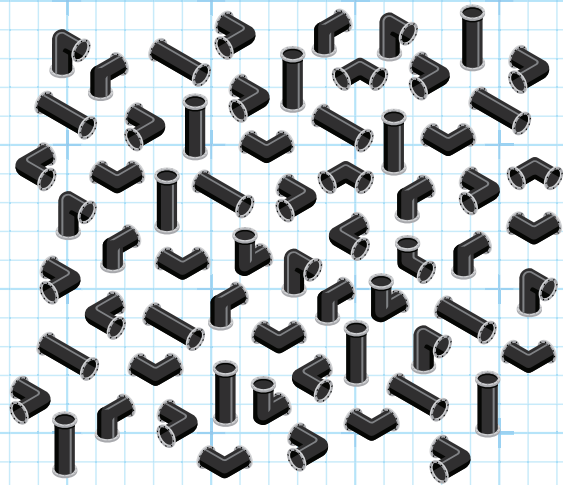

**THEM**

*Attending WEFTEC? Stop by booth 5314 to discuss solutions for your next project!*

## **FITTING SOLUTIONS FOR BYPASSES OF ALL SHAPES AND SIZES**

When it comes to fluid handling, sometimes more simply is better. More projects. More experience. More variety. Whether for a pipe-only project or a more traditional sewer bypass, we rise to the challenge, delivering right-sized solutions for your application. From engineered design to on-site setup, management and teardown, we've got you covered. For your next project, turn to the experts who can offer you more.

**24/7 EMERGENCY RESPONSE | 800-736-2504 | [SUNBELTRENTALS.COM](http://SUNBELTRENTALS.COM)**



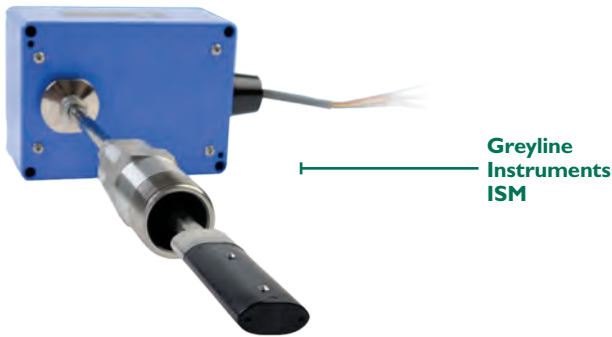

Greyline Instruments ISM



Ditch Witch Sandhog Backreamer

### Greyline Instruments insertion magmeter

The ISM 5.0 insertion magmeter from Greyline Instruments measures flow of conductive liquids in pressurized pipes ranging from 3 to 72 inches in diameter. The magmeter installs through a tap in the pipe wall. Installation through a full port ball valve allows easy retraction and reinsertion. A dual-electrode sensor and continuous auto-zero function ensures high accuracy even at low flow rates. **888/473-9546; www.greylines.com.**

### Ditch Witch backreamer

The Sandhog HD backreamer from Ditch Witch is compatible with the JT9, JT20, JT25 and JT30 horizontal directional drills and is designed for soft and sandy soils. Aggressive cutting, mixing and packing combine for more efficient pullback on the job. Carbide cutting teeth and spiral plates further improve pullback efficiency and lower torque while maximizing the capacity for fluid flow. A barrel-shaped body is designed to better sculpt a true-to-size bore path. Replaceable, hardened steel nozzles increase fluid flow flexibility. The backreamer is available in 2 3/4-inch shaft size with 2 IF threads and 3 1/4-inch shaft with 2 3/8 API threads ranging in diameter from 8 to 18 inches. **800/654-6481; www.ditchwitch.com. ♦**

# Every day is Earth Day.™

“I was named a Water Environment Federation Water Hero — professionals who ‘protect public health and the environment by cleaning the world’s water day after day.’ But it was a good crew of operators who pulled together as a team. It was great to work with such fine people.”

**Jimmy Stewart**  
**An Original Environmentalist**

CHIEF OPERATOR (2000-08)  
 Shoal Creek Water Reclamation Facility,  
 Clayton County (Ga.) Water Authority

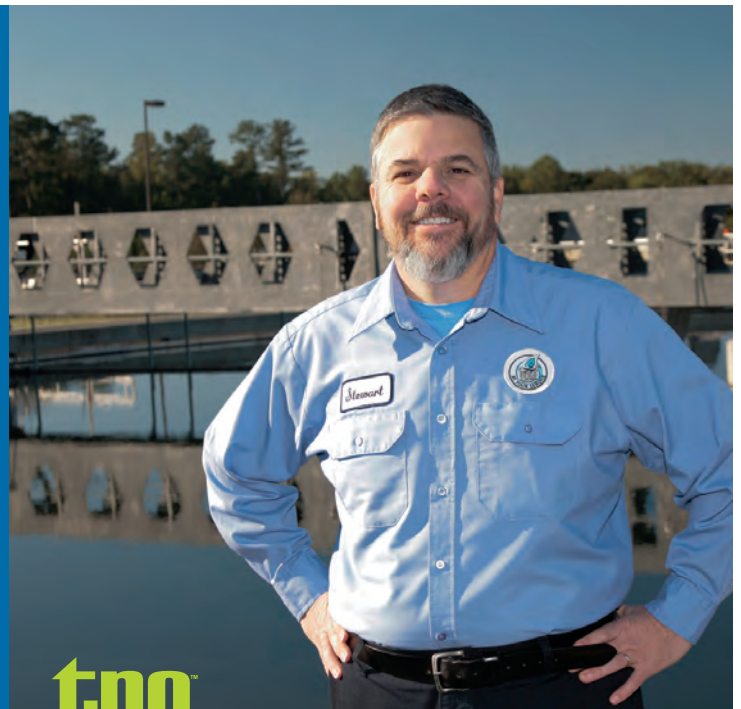

Read about original environmentalists like Jimmy each month in *Treatment Plant Operator*.

**FREE** subscription at [tpomag.com](http://tpomag.com)

COLE PUBLISHING INC.

*Proudly Serving the Environmental Service Industry Since 1979*



Looking Forward **VEGA**

High functionality.  
Low maintenance.

The VEGAPULS WL 61 radar sensor accurately measures water level without contact, saving users time and money in reduced maintenance.

[www.vega.com](http://www.vega.com)

**WEFTEC 2016:  
Booth #163**



## RapidView IBAK North America adds two dealers

RapidView IBAK North America added Sewer Equipment of Illinois as the exclusive dealer for RapidView IBAK North America pipeline inspection and rehabilitation equipment in northern Illinois and Wisconsin, and Sewer Equipment of Kansas as the exclusive equipment dealer in Kansas.

## RauschUSA adds two distributors

Fredrickson Supply (Grand Rapids, Michigan) and GPM Equipment Solutions (Arlington, Texas) joined the RauschUSA network of authorized distributors and will offer the entire line of RauschUSA pipeline inspection products.

## Makita U.S.A. wins vendor award

Makita U.S.A. was named Sphere 1 Vendor Partner of the Year for the second straight year at the membership's annual meeting in Orlando, Florida. Makita U.S.A. earned the best overall score on the Sphere 1 Annual Support Card, which ranks all 97 vendors on six separate criteria. Sphere 1 is a cooperative of independent tool, fastener and concrete accessory distributors.

## Hydra-Flex relocates headquarters

Hydra-Flex, manufacturer of fluid-handling equipment, moved its office and manufacturing facility to a larger site in Eagan, Minnesota.

## Open Spatial introduces touch capability in enlighten 3.3

Open Spatial introduced touch capability to enlighten 3.3, the web browser-based mapping application and geoportal. Users can now pinch-zoom gestures directly on the map and panels to make selections and execute functions from their desktop computers, tablets and smartphones.

## Woolpert names president

Scott Cattran was named president and CEO of Woolpert. Cattran has been with the national architecture, engineering and geospatial firm for 17 years, joining the company as phase manager in 1999.

## Cityworks adds three employees

Cityworks announced the hiring of Bridget Suda, Gregor Wilke and Larry Solien. Suda joined the sales department, while Wilke and Solien became part of the client relations team. The company also promoted Greg Walters to a position in the client services department.

## Virgo Fleet releases new catalog

Virgo Fleet, a retail supplier of truck accessories, released a new 84-page product catalog. Buyers can browse items in the catalog on the company's website, virgofleet.com.

## Cretex Speciality Products redesigns website

Cretex Specialty Products redesigned its website, www.cretexseals.com. New features include mobile optimization, easier navigation, product landing pages, and representative and distributor locator maps.

## LMK Technologies exec named to trenchless technology board

Rick Gage, vice president of sales at LMK Technologies, was named to the board of directors for the Midwest Society of Trenchless Technology. The nonprofit organization was established in 1998 to promote trenchless technology education and its benefits.



Rick Gage

## Wastequip announces dealer network for OEM parts division

Wastequip's Go To Parts division signed exclusive agreements with 10 dealers covering the South, Southeast, Midwest and Mid-Atlantic regions.

## Franklin Electric VP named to Hydraulic Institute's board of directors

DeLancey Davis, vice president of Franklin Electric and president of North America Water Systems, was appointed to the Hydraulic Institute's board of directors.



DeLancey Davis

## Itron signs contract to improve water access in Mali

Itron signed a contract with Malian Drinking Water Supply Management Company, water provider to 160,000 customers in Mali, to help the utility improve its water supply and decrease nonrevenue water.

## SubSurface Instruments acquires distributorship for Fuji Tecom locators

SubSurface Instruments acquired the master distributorship for the entire range of Fuji Tecom pipe and cable locators.



## Isuzu produces 30,000th N-Series gas truck

Isuzu Commercial Truck of America produced its 30,000th Isuzu N-Series truck on June 10 at the Spartan Motors facility in Charlotte, Michigan. Assembly of the N-Series gas trucks began at Spartan in April 2011. ♦

Got News?

Newsworthy items may include business expansion, honors and awards, new contract announcements, employee promotions, executive hires and new services.

Send your info to: editor@mswmag.com





# THE HIGHEST GRADE, BELOW GRADE



**A+**

## SPECIFICATION TEST

YES/NO

**ASTM F2561** - LMK's T-Liner® is an engineered, full-circle structural main-to-lateral connection. It renews lateral pipes in one continuous length up to 200 feet. T-Liner is one of the highest grade, below grade, liner systems that meet ASTM F2561.

**WATERTIGHT SEAL** - T-Liner, with a service life that matches the 50 year design life, uses molded Insignia™ hydrophilic gaskets that swell when exposed to water creating a compression seal that prevents infiltration tracking between the liner and host pipe.

**24/7 SUPPORT** - Each independent licensed distributor-contractor completes a standardized comprehensive training that includes classroom, laboratory and live, in-field exercises, giving them the ability to provide complete installation support services.

**Broad Sourcing** - T-Liner is available from a nationwide network of over 25 independent distributor-contractors.



COME SEE US AT:  
**WEQFAIR**  
MILWAUKEE

To learn more, call or visit us at:

[LMKTECHNOLOGIES.COM](http://LMKTECHNOLOGIES.COM) | 815.640.9302

Join us at

**weftec** 2016  
the water quality event™

**BOOTH #5413**



www.ParkProcess.com  
855.511.PARK

**WEFTEC Booth 3452**

**PARK PROCESS**  
a division of **PARK**

- Dewatering Containers
- Polymer Systems
- Mixing/Blending Equipment
- Oil/Water Separation
- Filtration Equipment
- Steel and Fiberglass Tanks
- Pump Lift Stations
- Storm Water Treatment
- pH Control Systems
- Backflow/Meter Systems
- Grease Interceptors
- Rainwater Harvesting

**Scum PRO™**  
**WWTP Skimming Rake**

**•IT FLOATS!**

- Light Weight, Heavy Duty Aluminum Construction
- Field Evaluated and Tested By WWTP Operators

★ Made In The USA **Rake with 12' Pole \$204.90**

**Fire Hydrant Lock**  
**\$79.95**

- Cast Iron and Steel Construction
- White Reflective Band
- No Special Tools Required
- Use Standard Padlocks or Barrel Locks

★ Made In The USA ★

**Plasticworks inc.**  
A Division of Lewis Plastics Co., Inc.  
**630.543.1750 • plasticworks.com**

**top hat risers**  
*an asept industries innovation*

**Easy to use Manhole/  
Water Valve Risers.**

**100% Recycled Tires**

**Top Hat Riser**  
**Manhole Cover**  
**Manhole Frame**

for more information, visit us online  
**tophatrisers.com**  
**315-730-2588**

**TRELLEBORG**

**Improved performance through the pipe cycle**

Whatever your demand, new seals for new pipes or rehabilitation solutions for existing infrastructure, Trelleborg has the expertise to boost your effectiveness.

Trelleborg Pipe Seals Milford, Inc.  
250 Elm Street, P. O. Box 301  
Milford, NH 03055, U.S.A.  
Tel: (800)626-2180  
(603)673-8680  
Fax: (603)673-7271  
[www.trelleborg.com/pipe-seals](http://www.trelleborg.com/pipe-seals)

**STOP LEAKS  
STABILIZE SOILS  
REPAIR CONCRETE**

Prime Resins offers products for repairing cracks, filling voids and sealing leaks of all sizes.

With best-in-industry 24/7 technical support, we can find solutions for any of your concrete repair needs. Give us a call. We'll walk you through it.

**PRIME RESINS**

**primeresins.com**  
**800.321.7212**

SubSurface Instruments

**NEED TO LOCATE BURIED PVC?**

**AMLPRO SERIES**

- Microprocessor Intelligence
- GPS Plotting & Tracking
- Noise Isolating Headphones
- Patented Technology

**PL-1500 & PL-2000** PIPE & CABLE LOCATORS

- Underground pipe & cable locators
- Available in single frequency and multi frequency
- Lightweight receivers w/ easy-to-read LCDs

**www.ssilocators.com**  
**PROUDLY MADE IN THE USA**

**HYDRO-EXCAVATION NOZZLES**

**RIPSAW™**

**DIG FASTER  
SAVE WATER**

**SWITCH BLADE™**

**HYDRA-FLEX**  
FLUID INNOVATION

952-808-3640  
[www.hydrflexinc.com](http://www.hydrflexinc.com)

**Cleaner**

**Every day is Earth Day.™**

"I'm fully aware of the conditions our technicians work in, and I do consider them to be my most important asset. Our policy is that when we walk away from a home, or any other project, we know that the line is open and flowing, and what the problem was to begin with, and where we might need to go next for a resolution."

**Teri Marinello**  
An Original Environmentalist  
President  
Fletcher Sewer & Drain, Inc.  
Ludlow, Mass.

COLEpublishing cleaner.com • 800.257.7222  
Proudly Serving the Environmental Service Industry Since 1979



**IndustrialOdorControl.com**  
A Broad and Economical Range of Odor Control Solutions



Pictured: Super Wolverine 8# Unit  
Patent # US 8,273,162

- Manhole Odor Inserts
- Pollution Control Barrels
  - Activated Carbon
- Vapor Phase Adsorbers
- Septic Vent Filters
- Custom Solutions

Simple Solutions DISTRIBUTING LLC  
Makers of the Wolverine Brand of Odor Control Solutions

866-NO-STINK (866-667-8465)  
973-846-7817 in NJ

**Convert to HOT WATER PRESSURE WASHING and JETTING**



**\$1,399+**

2GPM to 10GPM  
118° Temperature Rise  
4200PSI Rated  
Wheel Kits optional

**watercannon.com**  
800.333.9274

**The Plug Hug Fire Hydrant Cleaning System:**  
Make Fire Hydrants "Paint Ready" in 2 minutes  
**As Easy As ...**



**1 2 3**

Clear Snow Covered & Plowed Under Fire Hydrants in 60 Seconds



**THE PLUG HUG** www.theplughug.com  
719 313 2791  
douglasmarsshall@theplughug.com  
www.facebook.com/theplughug

**DYNAMIC REPAIRS**

**We Repair:**  
General Wire, Ratch, RIDGID, Hathorn Corp.  
Electric Eel, GatorCams, Vision Intruders  
and Vivax Inspection Cameras,  
Locators, Command Modules and Cables

**New & Refurbished Inspection Equipment For Sale**

**Rental Equipment Available**  
Daily & Weekly Rates

Ask About Our 48-Hr. Turn Around Time

**INSPECTION CAMERAS ARE OUR ONLY BUSINESS!**

**973-478-0893**

**DYNAMIC REPAIRS**  
40 Arnot St., Unit 20  
Lodi, NJ 07644  
dynamicablerepairs@yahoo.com  
www.dynamicrepairs.net



**Rausch Wheels Available**

**Cua Claws**  
A Simple Solution for Slippery PVC Pipe -  
**The Right Wheels**  
We resurface all makes of steel transport wheels-Including Rausch

CALL JERRY AT 714-697-8697  
www.cuaclaws.com

**QUICK**  
Usually Ships In 1/2 The Lead Time  
Horizontal and Vertical Pumps

Our vertical sump pump line offers up to 3000 GPM, 230' Heads and 26" depth. The horizontal end suction pump line offers up to 3000 GPM, 300' Heads, back pullout construction and semi-open impellers.

View our complete catalog and pump selection software on-line.

**VERIFLO** 37 YEARS 1979 2016



**VERIFLO PUMP COMPANY**  
The Industrial Pump Specialists  
513-530-0888 • www.veriflo.com

**Superior SMOKE**  
For SEWER TESTING

Superior Smoke Fluid Systems  
Smoke Candles • Smoke Blowers



MADE IN USA

Superior Smoke Testing  
The Most Cost Effective Method to Find Sources of Surface Inflow

SuperiorSignal.com/MSW

Repair deteriorating pipes from the **INSIDE** - with no excavation.



**HydraTite** INTERNAL JOINT SEALING SYSTEM  
HydraTech LLC • 513.827.9169  
www.hydratechllc.com

**DYE TRACERS**  
Solutions for:

- Infiltration
- Septic Systems
- Cross Connection
- Leaks and more...

**BRIGHT DYES**  
Division of Kingscote Chemicals



NSF Certified to ANSINFS 60

www.brightdyes.com • 1-800-394-0678

**Rely on Reelcraft** New!  
Turn-key jetter hose reels built to your specs



Made in USA

**REELCRAFT**  
www.reelcraft.com 800-444-3134

**Green Bison heavy duty degreaser**  
Superb product for grease control in collection systems. Emulsifies grease, improves high pressure cleaning performance. Highly recommended for cleaning/degreasing of tools, equipment and machinery. With Green Bison you do not have to trade efficiency for safety. Green Bison is a certified environmentally responsible product that utilizes natural and bio based ingredients, delivers industrial strength cleaning power while keeping your cost down.

Call us today 866-366-0587



**safe-tee chemical**  
safetechemical.com

This product meets the Green Seal™ standard for cleaning/degreasing agents based on its reduced hazard to humans, reduced aquatic impacts, reduced smog production, and low ozone depletion potential.

Restore deteriorating culverts with **RAPID** return to service.



**PolySpray** POLYUREA BASED SPRAY LINING  
HydraTech LLC • 513.827.9169  
www.hydratechllc.com



**Proudly Serving the Water Utility Market**

Since 1982!

MLT412 Mainline Tapping Tool

T752 Mini Tap XL

THE WEDGE Service Line Replacement Tools

BIG SHOT Underground Piercing Tools

Footage

Call us toll free or view our entire product line at:  
1-888-737-3668 • www.footagetools.com

**World Leader in Developing and Manufacturing Epoxy Resins**



- » Corrosion Protection Coating
- » Spray-on & Hand Applied Resin
- » CIPP Resins for Different Diameter Pipes
- » PVC Adhesive, 0% VOC
- » High Temperature Epoxy

Number One Epoxy Coating Based On Independent Testing



**510-782-1290**  
www.NeoPoxy.us

**INDUSCO** Enviro.com

Odor Control Scrubber Systems

- » More
- » Bigger
- » Better
- » Highest Quality

Since 1982

weftec 2016 Booth 6049

**CONFINED SPACE ENTRY PACKAGE**  
ONLY \$2,995

The best package on the market includes:

- 4-Gas Air Monitor
- 7' Tripod
- 3-Way Fall Protection
- Work Winch
- Full Body Harness



Add a Blower with 15' of duct for only \$350!  
Add a 5 Minute Escape Respirator for only \$500!

**MECH. 800.362.0240**  
www.mtechcompany.com

**MAINLINE MACHINE!**

**D-5 Key Features:**

- Runs 5/8" or 3/4" Tri-Max Cable for added flexibility and longer life
- High density polyethylene drum and belt guard will not rust or dent
- Auto cable feed for ease of operation
- Heavy duty 1/2HP capacitor type motor produces more torque and plenty of power



**Electric Eel**  
800-833-1212  
ElectricEel.com

**EMERGENCY SHOWER**  
THE FULL BODY WASH SYSTEM



Safety First  
Meets ANSI & OSHA requirements

**Emergency Shower Decontamination Booth**

Delivers immediate full body shower. Eye/face wash with positive stay open valves. Pre-plumbed to 1-1/4" IPT supply & 3" drain outlet.

Made in U.S.A.

For Prompt Price & Delivery  
**HEMCO** Call 800-779-4362  
ISO 9001:2008 Certified Company HEMCOcorp.com

**WESROC** REMOTE MONITORING SYSTEMS

Cellular Unit



WESROC's remote monitoring uses cellular, satellite, phone lines and internet communications to transmit liquid levels of all types. Our system can also monitor other readings like temperature, line pressure, run times, generator and moisture alarms.

WESROC can create additional profits for your business. How? Call us at 866.493.7762 and we'll explain our free profit analysis software that will add dollars to your bottom line.

**www.wesroc.net**  
1960 Ridgeview Road, Blair, NE 68008



**AQUA Operations**  
The water environment leader in operations, supervision and learning

---

CONTRACT OPERATIONS

OPERATOR EDUCATION

REGULATORY REPORTING

PLANS AND PROGRAMS

---

888-746-6535  
661-331-1181  
www.AquaOperations.com

Everyone talks about creating a greener environment.

You actually do it.

Find the tools you need to keep your communities green at  
**www.colepublishing.com**

Publishing environmental trade magazines since 1979.







**Data Flow Systems**  
**WATER & WASTEWATER SCADA Solutions**

Obsolescence-Proof  
 Secure  
 24/7

Getting SCADA is so much easier than you thought! ...

- Low Cost Rental Systems
- Now Offering Cell SCADA
- Configure For Your Budget
- Guaranteed Performance
- Exceptional User Support
- No Maintenance Contracts

Providing SCADA Since 1981

 **321.259.5009**  
 Booth 7512 [DataFlowSys.com](http://DataFlowSys.com)



Over 25 years of building quality equipment

**HotJetusa®**  
 DRAIN LINE JETTING EQUIPMENT

**Most Versatile Jetter On The Market!**



- 35 HP Vanguard
- Remote Control
- Cleans Drains from 2"-12"

On Sale For Only **\$24,995!**

**Fully loaded! Call for details!**

**1-800-213-3272**  
[www.hotjetusa.com](http://www.hotjetusa.com)

**Generator-Parts.com**

Online parts breakdowns to help you troubleshoot and identify repair parts.

**FULL LINE OF GENERATORS AND OEM PARTS FROM:**

**GENERAC KOHLER Cummins Onan**

**MANY PARTS IN STOCK:**

- Filters
- Fuel System Components
- Starter Motors
- Replacement Gaskets
- Solenoids
- Much More!

Same day shipping on in-stock inventory orders placed before 4 p.m. CST.

Our large midwest inventory reaches most places in 2-3 business days via standard shipping.

Government and Military Quotations Welcome

Trained & Certified Repair and Installation Staff  
 877-409-1618 • [sales@generator-parts.com](mailto:sales@generator-parts.com)

**Generator-Parts.com**

**"Your One-Stop Stopper Shop!"**

FOR 31 YEARS - HOME OF THE ORIGINAL  
**PIPE PLUG & NB BAG/ PILLOW DESIGN STOPPER**  
 [ SINGLE SIZE OR MULTI SIZE PIPE STOPPERS 4" & UP ]

- » SINGLE & MULTI SIZE PASS THRU PLUGS
- » MULTI SIZE PLUGS & MULTI SIZE LEAK LOCATORS
- » SINGLE & MULTI SIZE TEST PLUGS

» COMPLETE LINE OF SEWER & DRAINAGE TOOLS AVAILABLE

disc plugs | high pressure plugs | large inflatable pipe plugs | pipeline testing & acceptance plugs | pneumatic by-pass plugs

**SEWER EQUIPMENT CO. OF FLORIDA, INC.**

NEW SMYRNA BEACH, FL  
 IN FL 800.225.2952 | OUT OF FL 800.635.2323  
 IN CANADA 800.328.3318

[www.SewerEquipmentCo.com](http://www.SewerEquipmentCo.com)



**KWMI**  
 MANUFACTURING



The KWMI Easement Machine is an all-terrain rubber tracked power carrier designed specifically for the pumper-cleaner industry.

With the KWMI Easement machine you will have unparalleled access to manholes in **WETLAND AREAS, WOODED AREAS, NARROW ALLEYS**, practically anywhere.

The KWMI Easement Machine is built rugged in construction and is easy to operate.

**800-503-0076**  
[www.kwmiequipment.com](http://www.kwmiequipment.com)



**www.liftplaq.us**  
 Email: [llc@liftplaq.us](mailto:llc@liftplaq.us)  
 TEL: 786-600-1843

**CEMTECH**  
 Concrete Repair Products

**Cementitious Manhole Rehab Products**

**706.654.3677**  
[www.awcookcement.com](http://www.awcookcement.com)

Follow MSW on



[www.facebook.com/MSWMag](http://www.facebook.com/MSWMag) [twitter.com/MSWMagazine](https://twitter.com/MSWMagazine)



**Anthrafilter**  
 FILTER MEDIA  
 Since 1976

**Anthracite Filter Media**  
 Filter Sands  
 Filter Gravels  
 Activated Carbon  
 Filter Garnet  
 Ilmenite  
 Greensand



**SUPPLY | INSTALLATIONS REMOVAL & DISPOSAL**

Brantford, ON Canada  
 519.751.1080

Niagara Falls, NY  
 716.285.5680

Florida  
 800.998.8555

[www.anthrafilter.net](http://www.anthrafilter.net)

**GAS MONITOR SALE**



Micro Clip XL Multi-Gas  
 #MCXL-XWHM-Y-NA



Gas Alert Quattro  
 #QT-XWHM-A-Y-NA

**MRP**  
 MILWAUKEE RUBBER PRODUCTS  
**1.800.325.3730**  
[www.MilwaukeeRubber.com](http://www.MilwaukeeRubber.com)





**Now That's Smokin'!**  
 Tests up to 7500 cubic feet of pipe per minute  
**Turbo Fog MH75**  
 • Easy • Cost Effective • Compact •

**TURBO-FOG**  
 1.800.394.0678 www.turbo-fog.com

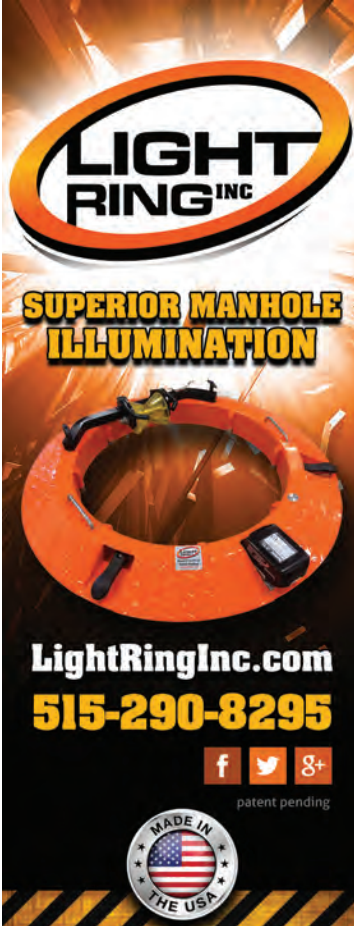

**LIGHT RING INC**  
**SUPERIOR MANHOLE ILLUMINATION**

LightRingInc.com  
**515-290-8295**

f t g+  
 patent pending

MADE IN THE USA

**Philmac UNIVERSAL TRANSITION COUPLINGS (UTC)**

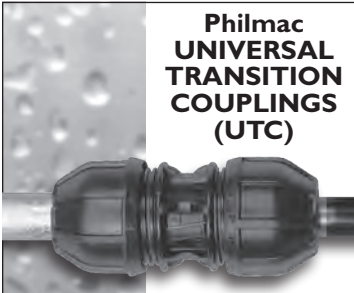

Connecting pipe sizes from 3/4" to 2"

- CTS PE & PEX • Steel
- PE IPS-OD • Copper
- PE SIDR 7 - 15 • Lead
- Galvanized Steel • PVC
- Stainless Steel • ABS

Rated 200psi @ 73°F and 150psi @ 100°F  
 100% Lead Free

**HARCO Fittings**  
 www.harcofittings.com  
 (800) 825-7094

HARCO

The road we've traveled leads to your success

Pioneers of the industrial cleaning equipment industry

Deep knowledge and understanding of your needs

Complete line of high-quality air and liquid vacuum trucks, sewer cleaning trucks, hydro-excavators, sweepers and other equipment

Broader geographic coverage

Responsive, reliable, flexible support: 24/7/365



RENTAL, SALES AND SERVICE  
**1-888-VAC-RENT**  
 ersvacrent.com

Let Us Build Your **JETTER**



**Diesel Propane Gas**

**AMERICAN JETTER.COM**  
**866-944-3569**



A Leading Distributor Of Polyethylene Encasements (Polywrap) And Other Waterworks Industry Products

**AA Thread Seal Tape Inc.**  
 1275 Kyle Court,  
 Wauconda, IL 60084

Ph: 800-537-7139  
 Fx:847-526-2209

www.aathread.com

**An Innovative System for Cost-Effective Wastewater Treatment**

Continuous Flow • In-line Media Regeneration

**Regenex™ Wastewater Treatment System**

- Captures organic contaminants
- Assists in discharge compliance
- Enhances treatment capability

What can the Regenex System do for you?  
 Contact us for a free treatability assessment and personalized system demonstration



Call us today!  
**(614) 588-3336**

The difference is clear • We can prove it!

**ABS Wastewater** (614) 588-3336  
 info@absmaterials.com  
 A Division of ABS Materials, Inc. Located in Wooster, OH

www.abswastewater.com

**Confined Space Kit**

- French Creek S50G M7 7' Tripod, 3-Way SRL, Winch w/ Galv. Wire
- BW MCXL 4-Gas Monitor
- Protecta FIRST 5 Harness AB17530

+ Add an 8" Allegro Blower with 25' ducting for just an additional \$313!



**\$3,127.75** FREE Shipping! UPS Ground\*  
 Get \$20 Off w/ Promo: PKCSK

**PKSafety.com/cs-kit**  
 or Call 800-263-7608 Today!

"They were true to their word on shipping and it was very fast." - bc 6/17/16  
 \*USA, excluding HI and AK



GET **EMAIL NEWS ALERTS** FOR MUNICIPAL **SEWER & WATER**

Go to **mswmag.com/alerts** and get started today!



# THROW AWAY THOSE EXTRA PIECES.

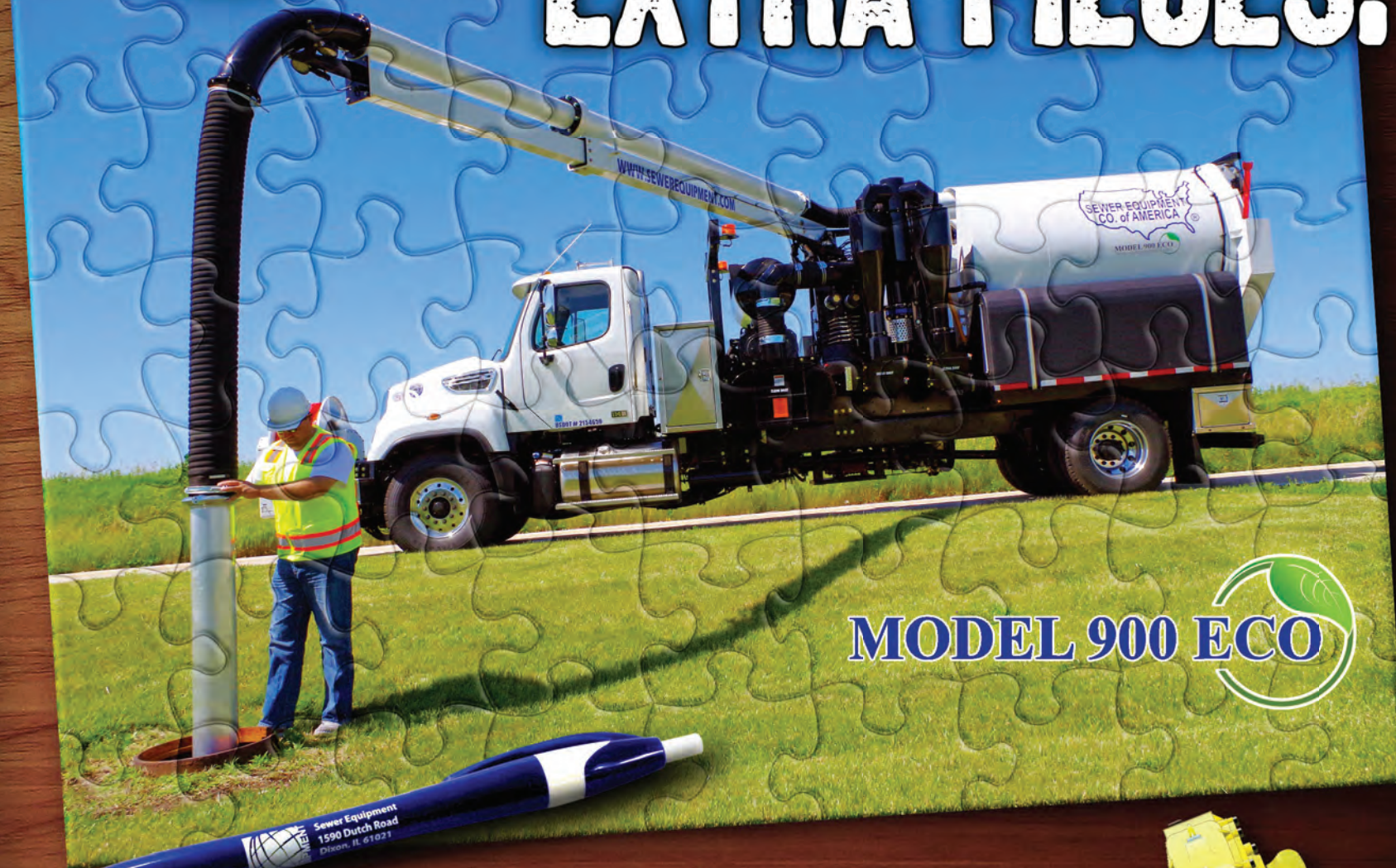

**MODEL 900 ECO**

**SEWER EQUIPMENT'S PATENT-PENDING HYDRO DRIVE SYSTEM, COMPLETES THE PUZZLE WITHOUT THE NEED FOR UNNECESSARY PIECES SUCH AS TRANSFER CASES OR TRANSMISSION-MOUNTED PTOs. SAY GOOD BYE TO COMPLICATED START-UP AND SHUT DOWN PROCEDURES AND HELLO TO INCREASED SAFETY FOR ALL OPERATORS BECAUSE WITH THE MODEL 900 ECO COMBINATION SEWER CLEANER...**



## **SIMPLICITY COMES STANDARD.**



WWW.SEWEREQUIPMENT.COM • 888-477-7611 • SALES@SEWEREQUIPMENT.COM



## PEOPLE/AWARDS

The city of **Fort Myers** received an Outstanding Achievement Award from the Florida Stormwater Association for the Ford Street Preserve filter marsh project. EnSite provided landscape architecture for the project. The project was designed to intercept all seasonal runoff from the Ford Canal and divert it through a constructed wetland system consisting of a control structure across Ford Street canal, a settling pond and two planted wetland treatment cells prior to discharging through an overflow weir to Billy's Creek.

The Pennsylvania Land Trust Association honored **West Lampeter Township** with the 2016 Government Conservation Leadership Award, which is given in recognition of demonstrated leadership in the conservation of special landscapes and critical natural resources. The township has used innovative, cost-effective methods to improve the health of local water and the Chesapeake Bay, and has adopted a land-use policy that protects both agricultural and natural resources.

Maryland-based environmental services firm **EA Engineering Science and Technology** was awarded a contract to undertake a stormwater management review on the island of Oahu, Hawaii. The firm will help the state of Hawaii Department of Transportation, Highways Division, Oahu District comply with national pollutant discharge elimination system requirements and its municipal separate storm sewer system permit. The 12-month contract has a year-to-year extension option for up to six years and a maximum value of \$4.8 million.

**Bill Boulanger**, utilities superintendent with Dover (New Hampshire) Community Services, received the Environmental Merit Award from the New England office of the Environmental Protection Agency for his innovation in addressing pollution concerns as a result of stormwater runoff.

The **Cannon River Watershed Partnership** and the city of **Northfield**, Minnesota, announced the 2016 Stormwater Pollution Prevention poster contest winners. Students submitted posters supporting the theme "Be the Solution to Stormwater Pollution." First place was Corrie Demas, Prairie Creek Community School. Second place was Marcos Gallardo, Greenvale Park Elementary School. And third place was Julian Vazquez, Greenvale Park Elementary School.

**Yenier Vega**, the stormwater utility manager for the town of Cutler Bay, received the Young Leader Award from the American Public Works Association's Florida Chapter in the stormwater category for the Southwest 212 Street drainage and roadway improvement project.

The Environmental Protection Agency honored **Boeing South Carolina** with the regional 2016 EPA Rain Catcher Award in the Commercial Category for the Stormwater Reuse Project in Charleston, South Carolina. The project involved a system to reuse stormwater from the site's three retention ponds for irrigation of site landscaping.

**Green Communities Canada's RAIN Community Solutions**, a program delivered locally by Greening Nipissing, was a recipient of the Ontario Ministry of the Environment and Climate Change 2015 Minister's Award for Environmental Excellence. The award recognizes environmentally innovative contributions to such things as climate change resiliency. RAIN Community Solutions is a program that was created in response to the growing impact that stormwater runoff and flooding was having on communities.

## LEARNING OPPORTUNITIES

### American Water Works Association

The AWWA is offering a webinar titled "What You Need to Know About Climate Risks to Water Utility Infrastructure and Assets" on Nov. 30. Visit [www.awwa.org](http://www.awwa.org).

### Wisconsin

The University of Wisconsin Department of Engineering-Professional Development is offering "Using WinSLAMM v. 10.2: Meeting Urban Stormwater Management Goals R324" on Oct. 6-7 in Madison. Visit [epdweb.engr.wisc.edu](http://epdweb.engr.wisc.edu). ♦

## CALENDAR

### Sept. 6-9

American Society of Agricultural and Biological Engineers International Drainage Symposium, The Commons Hotel, Minneapolis, Minnesota. Call 612/624-4230 or visit [www.asabe.org](http://www.asabe.org).

### Sept. 12-14

National Rural Water Association WaterPro Conference, Orlando, Florida. Visit [www.nrwa.org](http://www.nrwa.org).

### Sept. 24-28

Water Environment Federation Technical Exhibition and Conference, New Orleans Morial Convention Center, New Orleans, Louisiana. Visit [www.weftec.org](http://www.weftec.org).

### Sept. 28-Oct. 1

American Society of Civil Engineers 2016 Convention, Oregon Convention Center, Portland, Oregon. Call 800/548-2723 or visit [www.asce.org](http://www.asce.org).

### Nov. 2-3

WJTA-IMCA Conference & Expo, Ernest N. Morial Convention Center, New Orleans, [www.wjta.org](http://www.wjta.org).

### Nov. 13-17

American Water Resources Association 2016 Annual Conference, Florida Hotel and Conference Center, Orlando, Florida. Visit [www.awra.org](http://www.awra.org).

### April 23-26 (2017)

American Public Works Association 2017 North American Snow Conference, Iowa Events Center, Des Moines, Iowa. Visit [www.apwa.net](http://www.apwa.net).

### April 30-May 3 (2017)

American Water Resources Association 2017 Spring Specialty Conference, Snowbird Ski and Summer Resort, Snowbird, Utah. Visit [www.awra.org](http://www.awra.org).

Municipal Sewer & Water invites your national, state or local association to post notices and news items in this column. Send contributions to [editor@mswmag.com](mailto:editor@mswmag.com).



Searching  
for More?

More news at  
[MSWmag.com/featured](http://MSWmag.com/featured)

MUNICIPAL  
SEWER  
&  
WATER



# SIZE DOESN'T MATTER

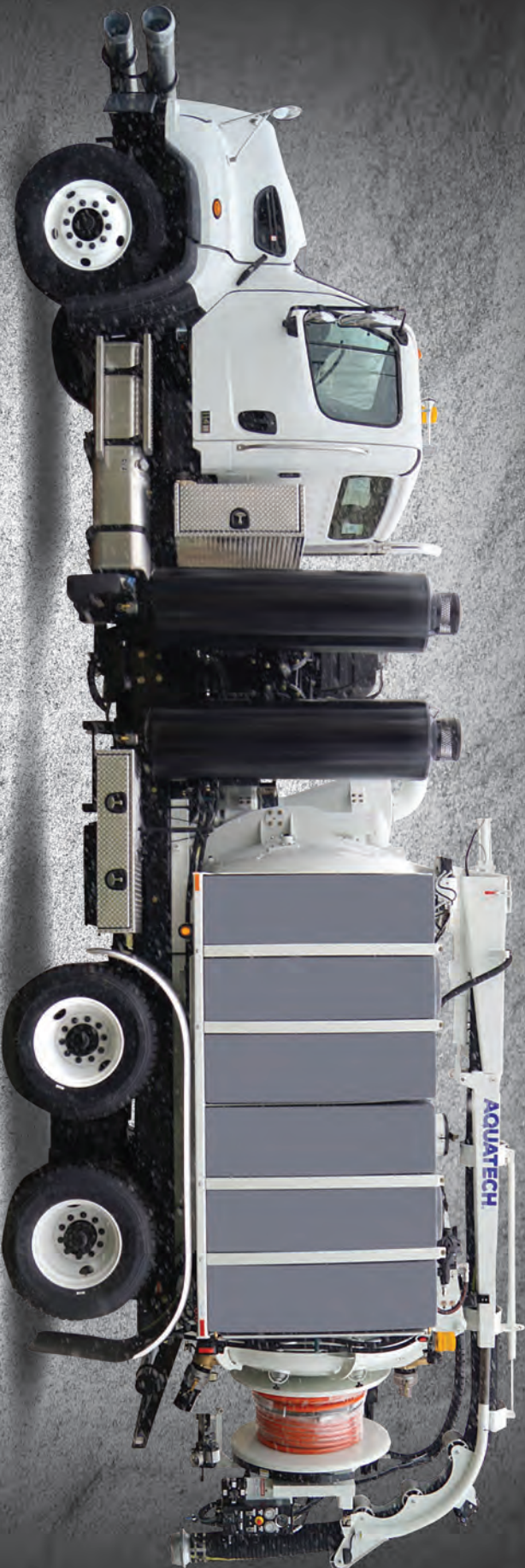

The only people who say "size doesn't matter" are the ones who don't want you to think it's important.

- 27" Hg blowers—the most powerful in the industry
- A water pump @ 150 GPM
- Lifetime warranty
- Owner-friendly, operator-friendly, mechanic-friendly
- Simplicity yields reliability
- Far more productive than other jet/vac units

**AQUATECH** **O'BRIEN**

Learn more about the industry's leading combination jet/vac system. We're just a call or click away!

Tel: 740.374.2306 // Fax: 740.374.5447 // [www.aquatechinc.com/msw](http://www.aquatechinc.com/msw)

COME SEE US AT:  
**WEQFAIR**  
MILWAUKEE



## COVERS

POND & TANK COVERS: Industrial & Environmental Concepts makes gas-collection covers, odor-control covers, heat-retention covers and wildlife-protection covers. Call 952-829-0731 [www.ieccovers.com](http://www.ieccovers.com) (MBM)

## EDUCATION

RoyCEU.com: We provide continuing education courses for water, wastewater and water distribution system operators. Log onto [www.royceu.com](http://www.royceu.com) and see our approved states and courses. Call 386-574-4307 for details. (oBM)

## POSITIONS AVAILABLE

**Subcontracting Opportunities** — South Coast Water District — Sewer Tunnel Stabilization and Pipeline Replacement Project: South Coast Water District located in Laguna Beach, California will be releasing construction bids for its "Tunnel Stabilization and Sewer Pipeline Replacement Project. State and federal requirements including DBE participation and prevailing wages apply to this project. Categories identified for possible opportunities for subcontractors and suppliers include concrete and shotcrete, rebar and structural steel, sewer pipe, spoil and waste hauling, surveying, security, and office supplies. A contractor "Meet and Greet" (in conjunction with the pre-bid meeting) will be held at the district's administrative offices in the August/September timeframe for all interested companies. To learn more about the project and subcontracting opportunities please register on the district's website at <https://www.planetbids.com/portal/portal.cfm?CompanyID=19768> site and sign up under RFI 17-02-0019 - Tunnel Subcontracting Opportunities. If you have questions you can e-mail the district's Contracts Manager at [mcollins@scwd.org](mailto:mcollins@scwd.org). (M09)

GapVax, Inc., a nationally recognized manufacturing business, is seeking a talented, highly motivated individual to fill a full-time Sales Position in the Midwest (Iowa based preferred) region. GapVax is the leading manufacturer of industrial and municipal vacuum units and hydroexcavation units in the United States. We provide the most reliable, comprehensive, and efficient mobile vacuum units in the industrial and municipal markets. Specifications of the position are listed on our website, [www.gapvax.com](http://www.gapvax.com), click on the Now Hiring link in the left hand column. Send resumes to or [betty@gapvax.com](mailto:betty@gapvax.com) or 575 Central Avenue, Johnstown, PA 15902. (MBM)

## PRESSURE WASHERS

Industrial Pressure Washer - New w/warranty \$9,500. 2,000psi, 18gpm. 999cc Kohler & AR pump. Will deliver. 321-800-5763 (MBM)

Honda horizontal GX engines, new in-the-box w/warranty. GX200QX - \$399; GX270QAG - \$579; GX390QA - \$599 delivered price. 800-363-9855 or [GXParts.com](http://GXParts.com) (MBM)

## SERVICE/REPAIR

**Dynamic Repairs - Inspection Camera Repairs:** 48 hour turn-around time. General Wire, Ratech, RIDGID, Electric Eel Mfg., Gator Cams, Insight Vision, Vision Intruders. Quality service on all brands. **Rental equipment available.** For more info call Jack at 973-478-0893. Lodi, New Jersey. [www.dynamicrepairs.biz](http://www.dynamicrepairs.biz) (MBM)

## TV INSPECTION

USED EnviroSight ROVVER System: Brand new RC90 camera. Cable reel (SN 360570) has new power supply, motor, clutch, cable (656') and winding rollers. 125 crawler (SN 0260768) has new top plate, side plates, axles and seals, plus new control board compatible with rear-view camera accessory (not included). CCU (SN 0160981) with new power card, new 56V card, new +/-26 card, and new card. Control pendant (SN 0492645) is compatible with RC90 camera and R225 crawler. \$27,500. Call 973-252-6700. (MBM)

**NEED TRACTION?** We make aftermarket more aggressive pads and chain assemblies for all chain-driven camera tractors. Custom, dependable, double-hole fabrication secured to high-quality carbon steel chain, or just pads and rivets. Also available: non-gritted pads. Samples upon request. **Pipe Tool Specialties LLC:** 888-390-6794; Fax 888-390-6670; [www.yourtractionpads.com](http://www.yourtractionpads.com) or email [pts4422@yahoo.com](mailto:pts4422@yahoo.com) (MBM)

## WATERBLASTING

Gardner Denver T-375M: Bare Shaft pump. Gardner Denver T450M Bare Shaft pump. Gardner Denver TF-375M 21 gpm @ 10,000 psi. Gardner Denver TX-450HB 21gpm @ 20,000 PSI. Gardner Denver TF-450MB 52gpm @ 10,000 psi. NLB 10-200. 34 gpm @ 10,000 psi. HT-150S 25 gpm max 10,000 psi max, Shell Side Machine, Wheatley 165: 30 gpm @ 10,000 psi. Wheatley 125 with aluminum bronze fluid end. Boatman Ind. 713-641-6006. View @ [www.boatmanind.com](http://www.boatmanind.com). (CBM)

**WATER JETTING EQUIPMENT:** We sell, repair and retrofit water blasters. Visit us at: [www.waterjettingequipment.com](http://www.waterjettingequipment.com) or phone 714-259-7700. (CBM)

# SOLD

Sell your equipment  
in *Municipal Sewer &  
Water* classifieds

Reach over 36,000 potential buyers each month when you list your equipment in the classified section. Plus, your listing is placed automatically online at the *Municipal Sewer & Water* website. That's two ways to move your equipment out of the parking lot!

## Why wait?

Go to  
[mswmag.com/classifieds/place\\_ad](http://mswmag.com/classifieds/place_ad)



Scan the code with your smartphone.



# Don't CIPP Another Pipe Without Adopting New Certification & Acceptance Standards!

## 1. Pre-CIPP - Vitrified Clay Pipe

Same Pipe, Scanned 3 Different Dates

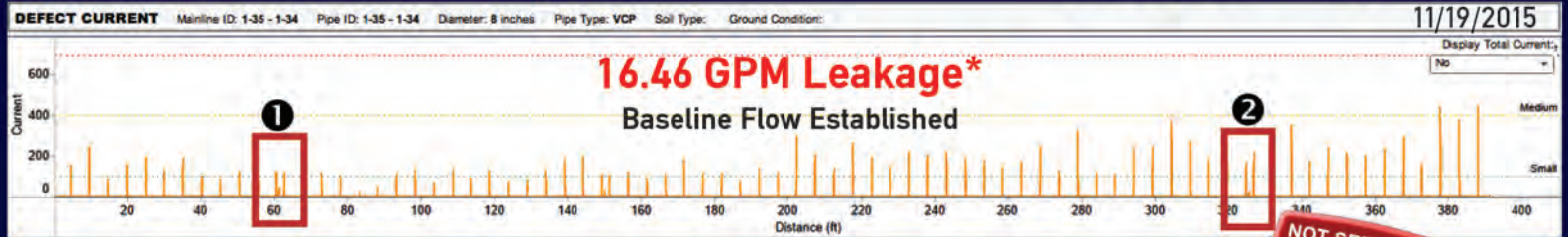

## 2. Post-CIPP - Poor Lateral Reinstatement Work!

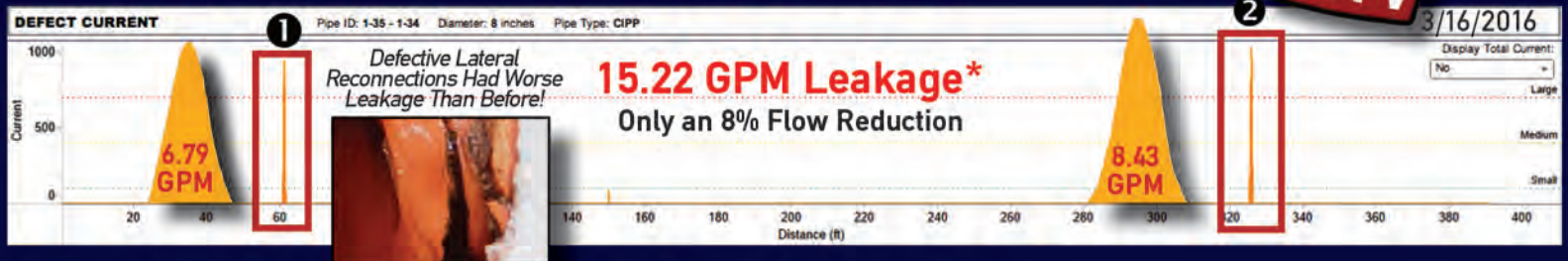

## 3. Post-CIPP - Lateral Connection Repairs Installed

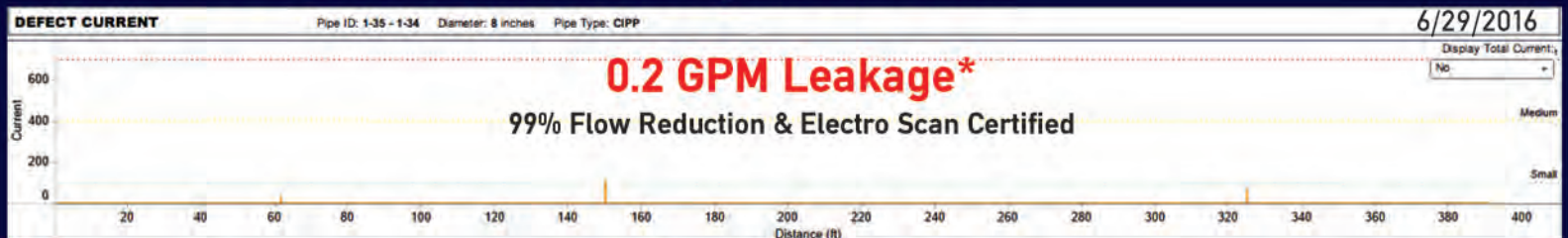

\*Each orange "spike" represents a location where electric current was able to pass through the pipe wall, where water can also leak through the pipe. A pipe should serve as an electrical insulator - *never allowing electricity to escape the pipe* - unless there is a leaking joint, crack, hole, or opening of any kind in the pipe.

## Fast, Accurate, & Unbiased Results

### Replace CCTV with Electro Scan & Quantify Infiltration Reductions!

Electro Scanning Inspection is recommended pre- & post-rehab, instead of CCTV, in the 7<sup>th</sup> EDITION, VOLUME 1, OPERATION AND MAINTENANCE OF WASTEWATER COLLECTION SYSTEMS manual.

In accordance with ASTM F2550-13.

US Patent #9143740 and International Patents Pending.



electro<sup>scan</sup>inc.

916.779.0660 | info@electroscan.com | www.electroscan.com | 1745 Markston Road, Sacramento, CA 95825



# VIVAX METROTECH

Inspect lateral and drain lines from 2 to 8 inches at a distance up to 400 feet with the vCam series of inspection cameras. Whether using the vCam push camera or a crawler system, locate both the cable and sonde with speed and accuracy. On-site training for locators or camera systems is provided free of charge via the Vivax-Metrotech national dealer network.



4 inch Clamp



5 Watt Transmitter



## *vLocPro2 5 Watt Locator Kit*

- Automatic gain control
- Bluetooth and GPS options
- Lightweight and ergonomic
- Left/Right arrows for fast locating
- Free phone/tablet app for utility mapping



## *vCamMX Mini Camera*

- Daylight viewable 8" display
- More than five hours of battery life
- Portable lightweight all-in-one system
- Inspect 1-1/2 to 4 inch diameter lines
- Interchangeable 0.70" and 1" cameras



## *vCam-5 Inspection Camera*

- Five hour of battery life
- Daylight viewable 8" display
- Inspect 3 to 8 inch diameter lines
- LACP Software compatible and ready
- 500 GB Hard drive with USB and SD ports

**Call us for your no obligation on-site demonstration!**

**Vivax-Metrotech Corporation**

3251 Olcott Street  
Santa Clara, CA 95054, USA

Toll Free: 800-446-3392  
Fax: +1-408-734-1415

Email: [sales@vxmt.com](mailto:sales@vxmt.com)  
[www.vivax-metrotech.com](http://www.vivax-metrotech.com)



\*SEE THIS UNIT AT THE TRI STATE SEMINAR IN LAS VEGAS, SEPT. 20-22

**WEQFAIR**  
Wastewater Equipment Fair

Sept. 12-13

See You  
There!



40 YEARS OF PROVEN TECHNOLOGY

**YOU ARE  
NOT GOING  
TO WANT  
TO MISS THIS  
RECYCLER**



Manufacturing the easiest to operate  
and maintain Combination JetVacs,  
Hydro Excavators, Air Movers, Skid-mounted  
Vac Units...all CUSTOM-Built for YOU!

**Call today for your demo!**

888-442-7829

W W W . G A P V A X . C O M

NEW HOURS



PartsExpress 8 am - 5:30 pm. EST  
Service/Warranty 8 am - 4:30 pm EST





MARIA  
MAKES SURE WE  
DON'T HAVE  
ANY INVENTORY  
ISSUES.

DARN  
SURE.

Because building tough reliable trucks  
takes tough reliable people.

With over 15 years at Vac-Con, nothing gets moved out of inventory without Maria knowing about it. Maria lives out “more power to you” every day. It’s not just our tagline, it’s in everything we do: our technology, our culture, and our leadership. Yes, our trucks are engineered to be powerful, but they’re also built by smart people who keep the end-users in mind. They give you a machine that gets the job done. [GO ON-LINE TO LEARN MORE.](#)

[VAC-CON.COM](#)

VAC-CON IS A SUBSIDIARY OF HOLDEN INDUSTRIES, INC.. A 100% EMPLOYEE-OWNED COMPANY

 **VAC-CON**  
MORE POWER TO YOU

A HOLDEN INDUSTRIES Company